

CONSEW[®]

OPERATING INSTRUCTIONS

FOR

206RB-5

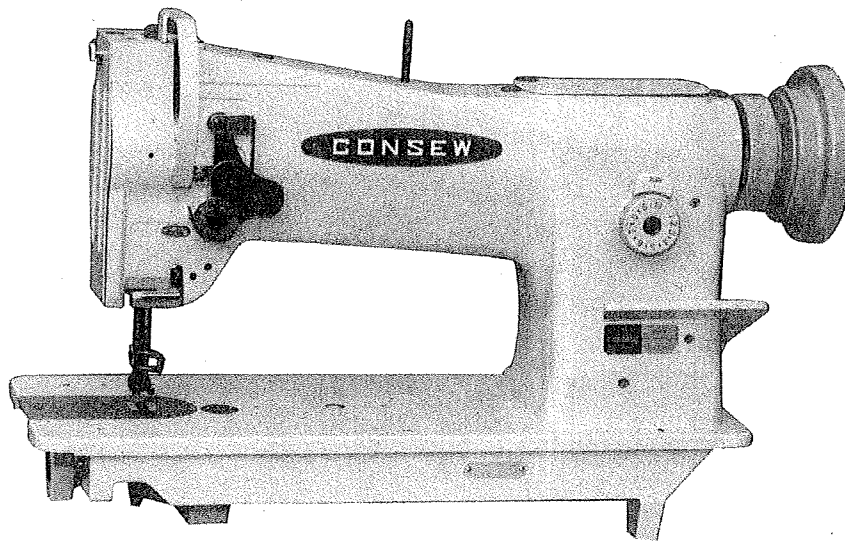

CONSOLIDATED SEWING MACHINE CORP.

- INDEX -

CONTENTS

	Page
Setting up the machine	1
Breaking-in & Direction of rotation	1
Oiling	2
Needle	4
Thread	4
Winding the lower thread on the bobbin	5
Adjustment of the bobbin winder	5
Removing and inserting the bobbin	6
Threading the machine	7
Regulating the thread tensions	8
Adjusting the lift of the alternating presser feet	9
How to re-set the safety clutch mechanism	9
Extra slotted needle plate	9

INFORMATION FOR ADJUSTMENT

Adjusting the height of the feed dog	10
Relative position of the feeder to needle plate	10
The position of the needle and the needle hole of the feeder	11
Timing the needle with feed dog	12
Adjusting the height of the needle bar	13
Timing between the hook and the needle	14
Adjustment of bobbin case opener	14
Adjusting the height of the presser feet	15
Timing of the vibrating presser foot	16
Adjustment of the clearance between feed forked connection and feed fork collar	16
Adjusting the thread controller spring	17
Adjustment of spring tension of safety clutch	18
Supplementary information on oiling	19

SETTING UP THE MACHINE (Fig. 1)

Before setting up the machine on the table, attach the relative parts to the table.

- | | | | |
|-----------------------|-----------------|-------------|-------------------|
| (1) Stand and treadle | (2) Motor | (3) Oil pan | (4) Hinge |
| (5) Maching head | (6) Knee lifter | (7) V belt | (8) Bobbin winder |
| (9) Cotton stand | (10) Prop | | |

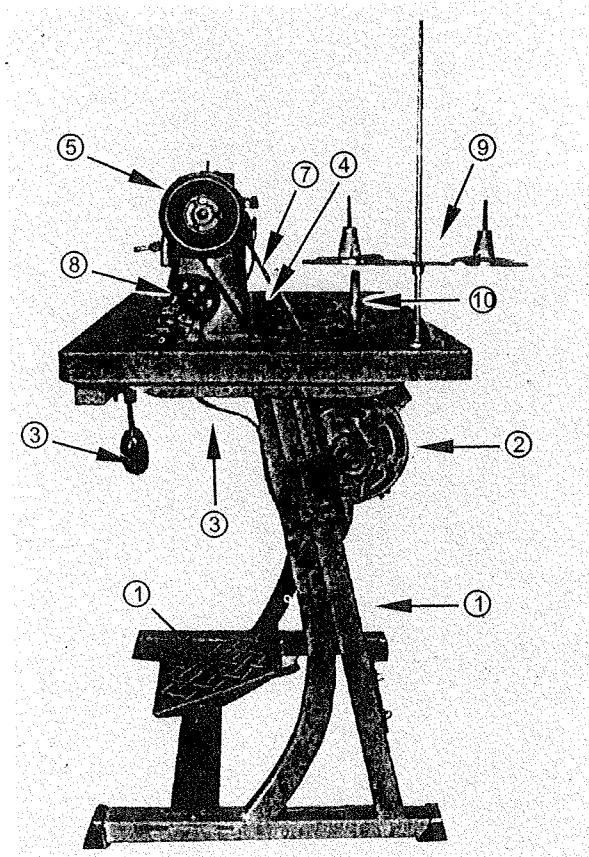

Fig.1

BREAKING-IN & DIRECTION OF ROTATION

To assure durability and trouble-free operation, it is imperative that for the first several weeks of operation the maximum speed is held to no more than 2000 RPM in order to allow the parts to become properly broken in.

In operation the handwheel of the machine always turns toward the operator.

To avoid tangled threads and jamming of the sewing hook, do not turn handwheel otherwise.

SPEED

Maximum operating speed after a break-in period is 2400 stitches per minute depending, of course, on the type of material being sewn, its thickness and that of the seams being crossed.

OILING

Do not operate the machine, even if only for testing, unless it has been properly oiled at every spot requiring lubrication.

The arrows on the following illustration indicate these spots.

(Fig. 2~Fig. 6)

NOTE: During the breaking-in period a new machine should be oiled more frequently.

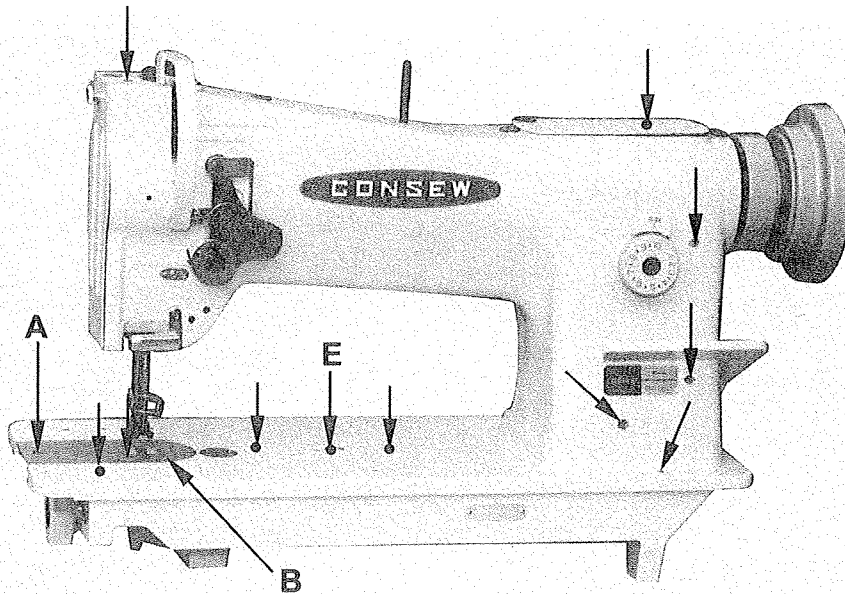

Fig. 2

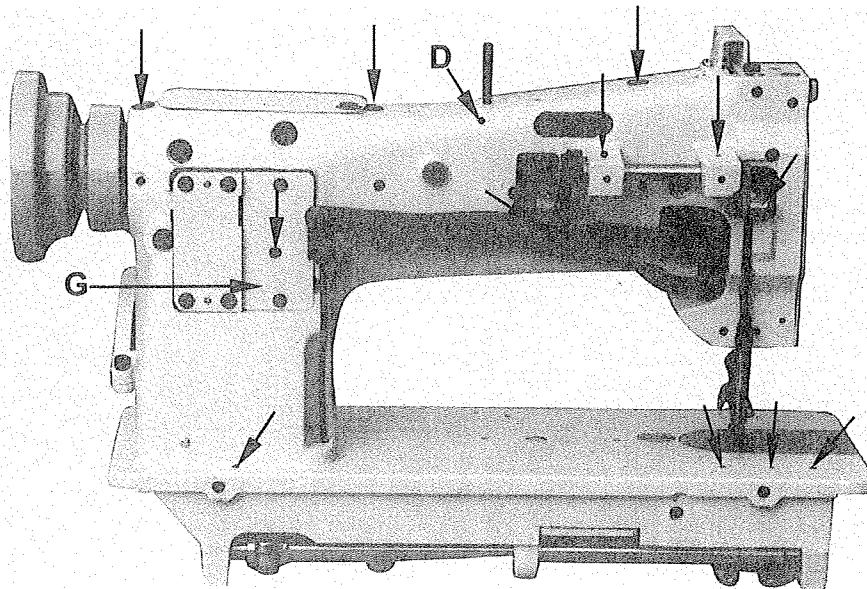

Fig. 3

↓ (Without Alphabet) marked for Oiling points only.

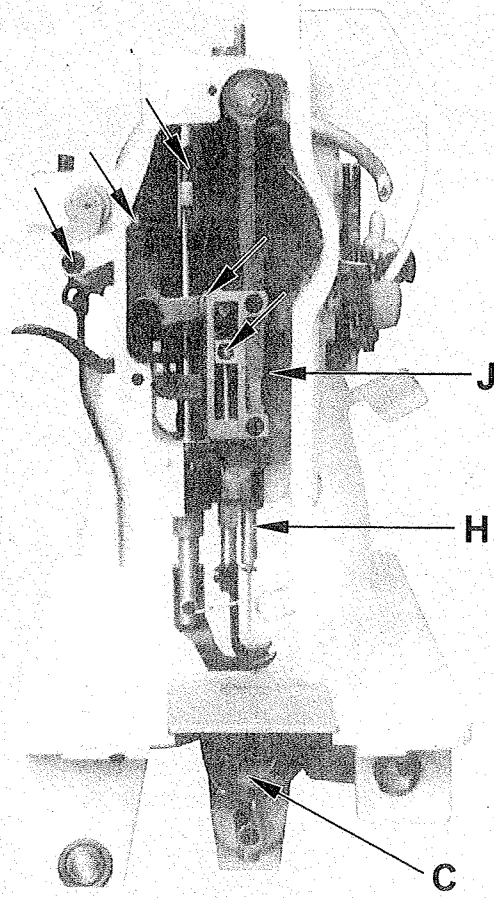

Fig. 4

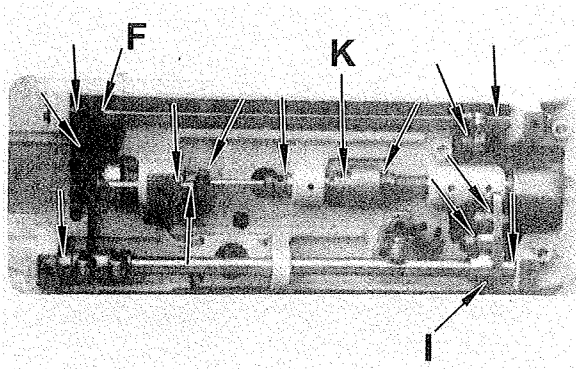

Fig. 5

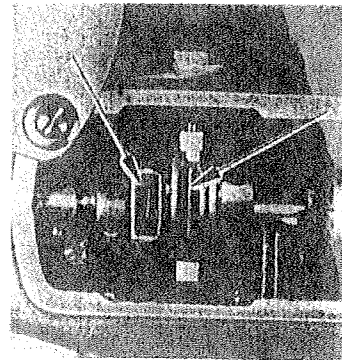

Fig. 6

↓ (Without Alphabet) marked for Oiling points only.

NEEDLE (Fig.7)

CONSEW 206RB is set up to use standard style DPx17. The size of the needle to be used should be determined by the size of the thread, which must pass freely through the eye of the needle.

HOW TO ATTACH THE NEEDLE

1. Turn the machine pulley over toward you until the needle bar^① moves up to its highest point.
2. Loosen the needle set screw^② and put the needle ^③ up into the needle bar as deeply as it will go, with the long groove of the needle faces the left.
3. Tighten the needle set screw securely.

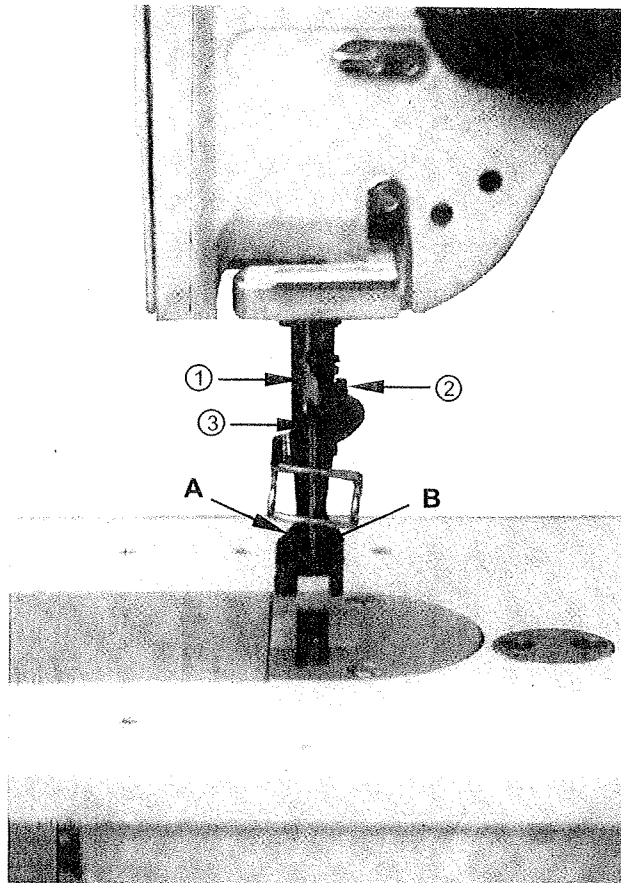

Fig.7

TEREAD

Cotton, synthetic or silk thread can be used according to your purpose.

* Always use left twisted thread for upper (needle) thread, but you can use either right or left twisted thread for lower (bobbin) thread.

WINDING THE LOWER THREAD ON THE BOBBIN (Fig.8)

1. Push a bobbin on the bobbin winder spindle ③ as far as it will go.
2. Pass the thread from the thread stand downward through the eye ① in the tension bracket, then between and around the back of the tension disc ②.
3. Bring the thread forward toward the bobbin and wind from below in clockwise direction several times around the bobbin.
4. Push the lecer ④ toward the other side so that the pulley and V belt (⑦ Fig.1) will engage and then start the machine.
5. The pulley will automatically be free from the belt and stopped after the bobbin is filled with thread.

THE ABOVE OPERATION CAN BE DONE WHILE SEWING.

ADJUSTMENT OF THE BOBBIN WINDER

1. IN CASE OF UNEVEN WINDING:

If the thread does not wind evenly on the bobbin, loosen the screw ⑤ in the tension bracket and move the bracket to the right or to the left as may be required, then tighten the screw ⑤.

2. WINDING AMOUNT OF THREAD:

Adjustment screw ⑥ can be turned in or out to increase or to decrease the amount of thread wound on the bobbin.

3. WINDING STRENGTH:

Strength of the winding can be adjusted with the nut ⑦.

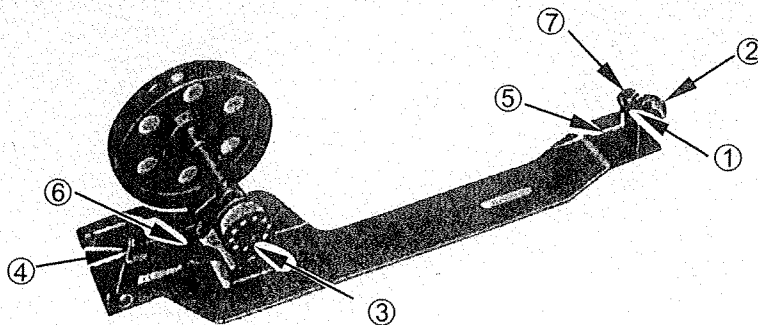

Fig. 8

REMOVING AND INSERTING THE BOBBIN

1. Lift the needle bar to its highest point, place the feed dog at this side in its travel! turning the machine pulley, and open the slide plate (A, Fig.2)
2. Pass left hand under table into opening on drip pan. With left thumb and index finger, open the hinged latch (C, Fig.4). And pull bobbin case and bobbin from rotary hook. While the latch is held open, the bobbin will be retained in the bobbin case. Release of the latch and turning of the open side of the bobbin case downward will cause the bobbin to drop out.
3. Hold the bobbin between the thumb and the forefinger of your right hand and pull out a length of about 5cm of thread. Holding the bobbin case in your left hand turn the open side up and place the threaded bobbin into it. (Fig.9)
4. With the right hand guide the thread into the slot in the edge of the bobbin case. Then pull the thread to the left, under the tension spring (①, Fig.9) and into the delivery eye. In order to keep the bobbin from dropping out of the case when it is turned with the open side down, always keep the hinged latch (C, Fig.4) at the front of the bobbin case open.
5. Take the threaded bobbin case by the latch (C, Fig.4) and place it on the center stud of the bobbin case holder. Release latch and press bobbin case on to center stud until the latch catches the undercut thereon with a click that can be heard. Permit about 5cm of bobbin thread to hang down freely. Be sure to push the slide plate to the right before starting to sew.

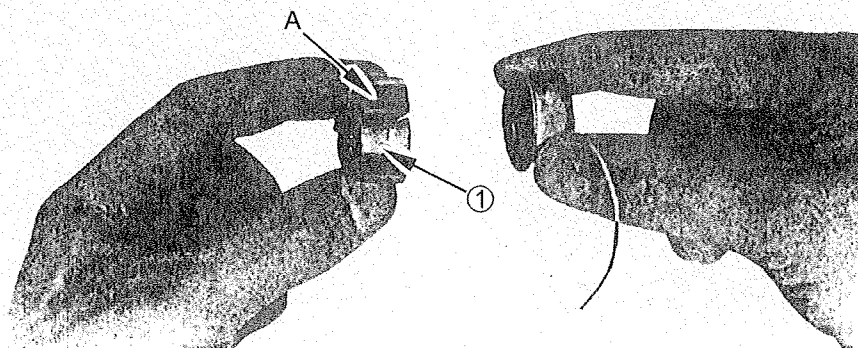

Fig. 9

THREADING THE MACHINE (Fig. 10)

1. Raise the needle bar to its highest point and lead the thread from the thread stand the following order:

From the thread stand lead the thread from back to front through the lower guide hole in pin ① on top of the machine arm, then again from right to left through the upper guide hole in this pin. Pass thread in weaving fashion through the three holes in guide ②, and from right to left over and between the tension discs ③. Now pull thread downward and from right to left beneath and around thread controller ④, continue to pull thread upward against the pressure of the wire spring into the fork ⑤, in the thread controller. Guide upward through the point of controller discs ⑥, and thread guide ⑦, and from right to left through the eye in take-up lever ⑧, down through thread guide ⑦, again and then through ⑨ ⑩ ⑪ and from left to right through the eye of the needle ⑫.

2. After the above threading, hold the end of thread with your left hand, and turn the machine pulley with your right hand so that bobbin thread may be picked up by needle thread. And put their ends of thread back through under the presser foot for starting operation.

TO REMOVE THE WORK

Raise the needle bar to its highest point, lift the presser foot and draw the fabric back and to the left. Cut the ends of the threads a few centimeters.

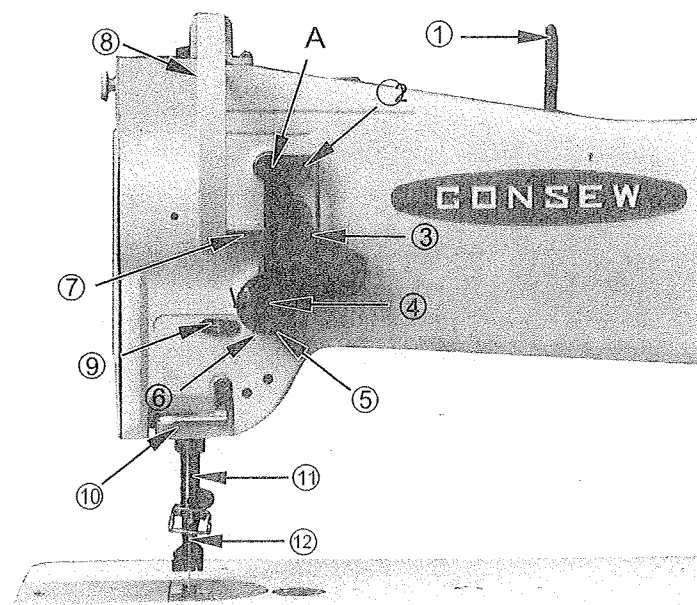



Fig. 10

REGULATING THE THREAD TENSIONS

For ordinary stitching, the tension of the upper and the lower threads should be equal so as to lock both threads in the center of the material.

 perfect stitching

If the tension on either thread is stronger than on the other, imperfect stitching will be the result. If the tension on the upper thread is greater than that on the lower thread, it will lie straight along the upper surface of the material.

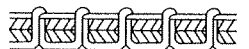
 Tight tension of needle thread

If the tension on the lower thread is greater than that on the upper thread, the lower thread will lie straight along the underside of the material.

 Loose tension of needle thread

1. Tension of the Upper (Needle) thread:

Before adjusting the tension of the upper (needle) thread, be certain that the presser foot is let down and not in lifted position.

To adjust tension, turn serrated nut (A, Fig. 10) on tension device to the right to increase tension and to the left if you desire to decrease it.

2. Tension of the Lower (Bobbin) thread: (Fig. 9)

The lower (bobbin) thread tension is controlled by the larger screw "A" (Fig. 9) near the end of the spring at the outside of the bobbin case.

Turning this screw to the right (clockwise) will increase the thread tension, while turning it to the left (counter-clockwise) will decrease it.

ADJUSTMENT OF THE PRESSURE ON THE MATERIAL (Fig. 3)

The pressure of the presser feed is adjusted by the screw (D, Fig. 3) with screw driver. To increase the pressure, turn the screw to the right and to left if you desire to decrease it.

Adjusting the stitch length (Fig. 12)

While pressing the stopper ②, turn the stitch length dial ① to the left and right to align the stitch length number with the reference line on the stopper ②.

- * The larger the number, the longer the stitch length will be.
- * When turning the stitch length dial ① from a larger setting to a smaller setting, it will be easier to turn the dial if the reverse stitching lever ③ is pushed to the halfway-down position.

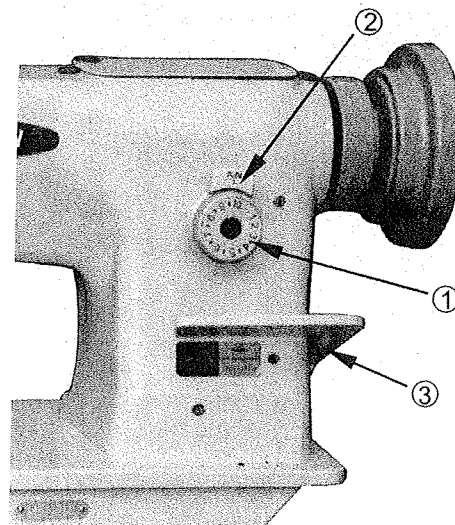

Fig. 12

ADJUSTING THE LIFT OF THE ALTERNATING PRESSER FEET (Fig.13)

The thickness of the material sewn should control the height of the lift of the alternating presser feet. The lift should be just enough for clearance of the material.

1. With normal adjustment both feed lift to equal height:

To alter lift, loosen the wing nut ① and move the link and stud assembly along the slot-move up to raise the feeding presser foot and push down to lower this foot. Tighten wing nut upon completion of adjustment.

However, some materials may require unequal height of lift.

2. When altering the lift of the lifting presser foot (A, Fig. 7) unequally against that of the vibrating presser foot (B, Fig. 7) or vice versa, see the instructions "ADJUSTING THE HEIGHT OF THE PRESSER FEET".

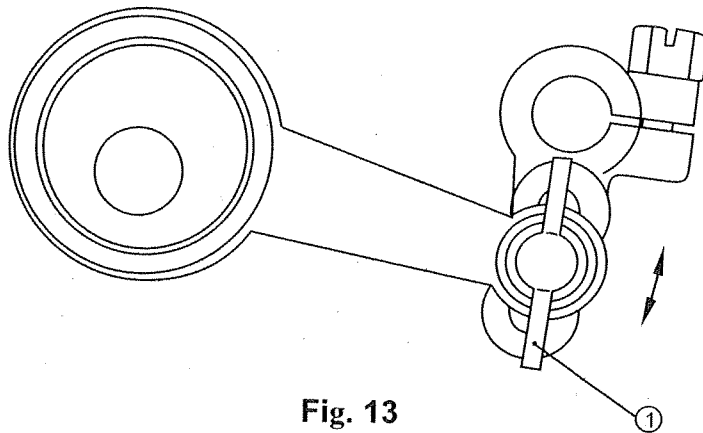

Fig. 13

HOW TO RE-SET THE SAFETY CLUTCH MECHANISM

The sewing hook and its mechanism are protected by a safety clutch.

If it should become necessary to re-engage the safety clutch, depress button (E, Fig. 2) in the bed plate of the machine. At the same time, turn machine pulley until the locking mechanism re-engages the drive shaft beneath the bed of the machine. Open bed slide plate and rock the machine pulley back and forth to remove any foreign matter which may have lodged itself in the hook. Do not use any sharp-edged tools, etc., lest the hook be damaged.

EXTRA SLOTTED NEEDLE PLATE (You will find this in accessories box.) (OPTIONAL EQUIPMENT)

If you put this extra slotted needle plate, you can use this machine without a feeder for sewing leather, vinyls, etc. without visible marks.

INFORMATION FOR ADJUSTMENT

ADJUSTING THE HEIGHT OF THE FEED DOG

The maximum height of the feed dog(①, Fig. 14) from the surface of the needle plate (②, Fig. 14) is normally 1mm.

To adjust this height:

1. Lay down the machine head toward the other side, and turn the machine pulley so as to raise the feed dog to its highest point.
2. Loosen bell crank screw (F, Fig. 5) and adjust the height of the feeder by raising or lowering it.
3. Securely tighten the screw upon completion of adjustment.

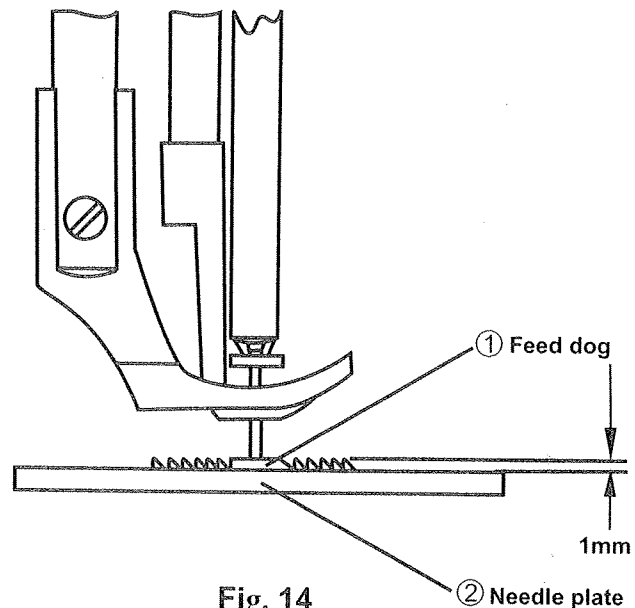

Fig. 14

Feed dog 1mm Needle plate

RELATIVE POSITION OF THE FEEDER TO NEEDLE PLATE

1. Place the feed regulating dial(②, Fig. 12) on the minimum position.
2. Turn the machine pulley so as to raise the feed dog to its highest point.
3. Lay down the machine head toward the other side, and loosen the screw (I, Fig. 5)
4. Adjust to be 32.1mm from the edge of the needle plate to the center of the needle hole on the feed dog (see Fig. 15)
5. Securely tighten the screw

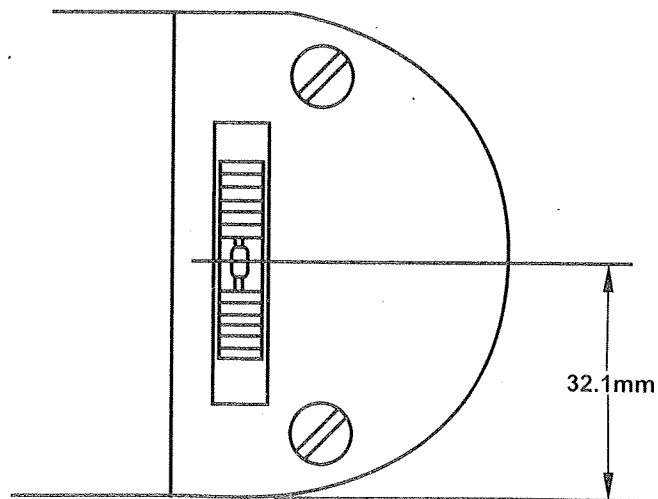

Fig. 15

THE POSITION OF THE NEEDLE AND THE NEEDLE HOLE OF THE FEEDER

Turning the machine pulley to lower slowly the needle bar, check whether the needle descends to the center of the needle hole of the feeder or not. (Please check again the needle is perfect one.)

If the needle does not enter into the center of the hole;

1. Remove the cover (G, Fig. 3) and loosen the screw (①, Fig. 16) slightly.
2. Holding the bottom of the needle bar rock frame (H, Fig. 4), move it as may be required to get the correct position to the feeder.
3. Tighten the screw and close the cover

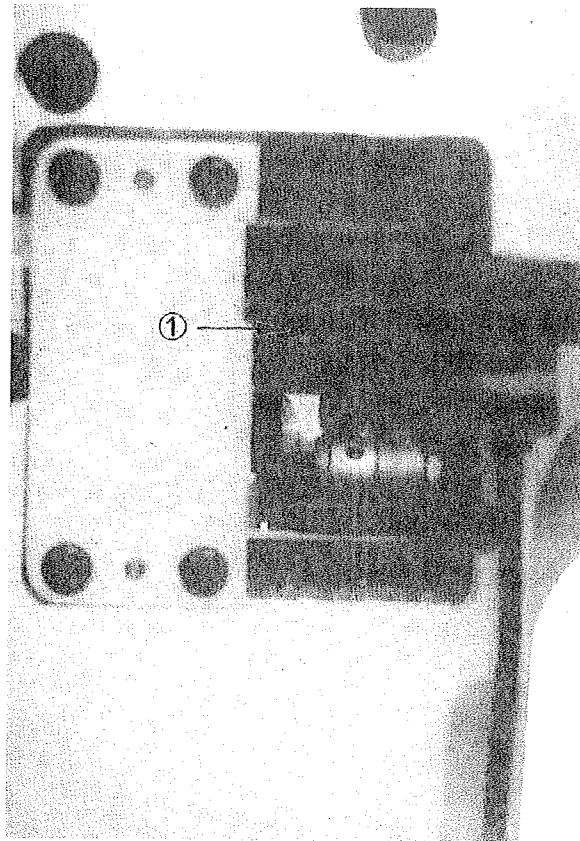

Fig.16

TIMING THE NEEDLE WITH FEED DOG

It is important that the timing relationship between the needle on its downward stroke and the feed dog movement is maintained at all times. When the scarf of the needle on the downward stroke reaches the top surface of the feed dog, the feed dog movement must start.

When adjustment is required, use the following procedure to change the position of the cam (③, Fig. 17):

1. Open cover plate (①, Fig. 17) and loosen two screws (②, Fig. 17).
2. Normally put the arrow mark of the cam (③, Fig. 17) on the V ditch (⑨, Fig. 17) of arm shaft (⑧, Fig. 17).
3. As fine adjustment, turn the machine pulley to place the needle at lmm up from its lowest point and pushing the stitch length regulating lever (③, Fig. 12) up and down, turn the cam (③, Fig. 17) and set this at the point both the needle and the feeder rest.

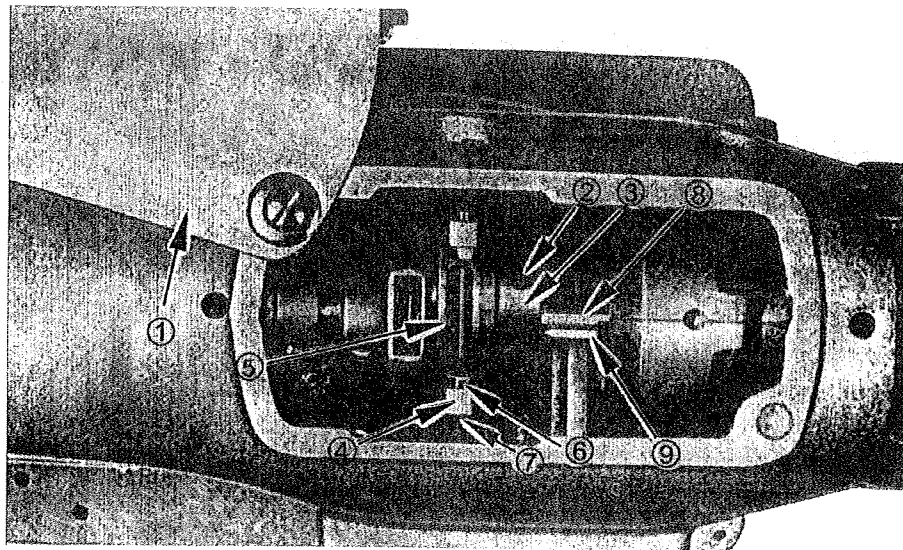

Fig.17

ADJUSTING THE HEIGHT OF THE NEEDLE BAR (Fig.18)

When the needle bar is at its highest point, normally the measurement between the surface of the needle plate and the upper end of the needle eye is 22.3mm. (Fig. 18)

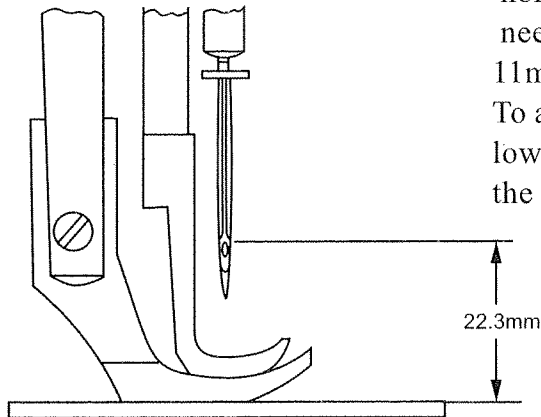

Fig. 18

You can also adjust this at its lowest point. In this case, normally the measurement between the surface of the needle plate and the upper end of the needle eye is 11mm.

To adjust this, loosen the screw (J, Fig.4) and raise or lower the needle bar as may be required. Then, tighten the screw upon completion of adjustment.

NOTE: These measurements are approximate standard, accordingly, following final adjustments "TIMING BETWEEN THE HOOK AND THE NEEDLE" are recommended.

TIMING BETWEEN THE HOOK AND THE NEEDLE (Fig.19)

After setting the needle bar height, set stitch length to minimum, turn the machine pulley toward you until the needle bar reaches its lowest point.

Continue turning and allow the needle bar to rise about 2mm while on its upward stroke. With needle bar in this position, the point of the sewing hook should be at the center of the needle, and normally, the measurement between the hook point and the upper end of the needle eye should be 2.4mm, further the clearance between the hook point and the needle hollow should be about 0.05 to 0.1mm.

1. If the sewing hook should not be timed correctly, loosen the three set screw (K, Fig.5). Turn the hook shaft to align the hook point with the center of the needle. Re-tighten the three set screws and re-check the timing of the sewing hook.
2. To adjust the clearance between the hook point and the needle hollow, loosen the two screws (①, Fig. 20) and move the hook to the right or to the left as may require. Please note one of the two screws is placed on the V ditch of hook shaft. Therefore, keep the screw on V ditch during adjustment. Re-tighten the screws.

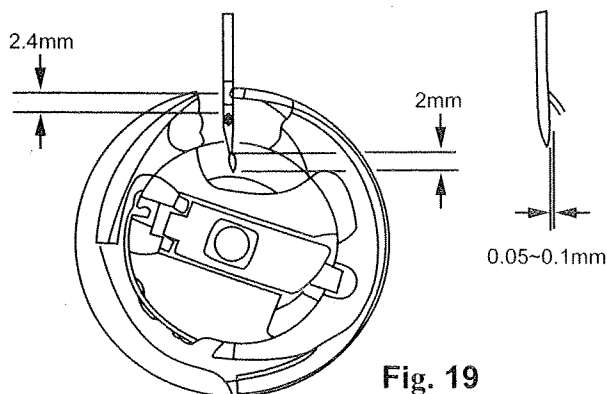

Fig. 19

ADJUSTMENT OF BOBBIN CASE OPENER

(THREAD RELEASE FINGER)

The bobbin case opener facilitates the passage of the needle thread loop by slightly nudging the bobbin case holder creating a slight rotating movement of same. This movement at that very instant opens a clearance gap between the notch on the bobbin case holder and the tab of the hook retainer permitting the needle thread loop to be drawn easily through the gap.

I) Clearance between the opener and projection of hook (Fig.20 and 21):

1. Loosen the screw (②, Fig. 20)
2. Adjust the clearance between projection of hook (①, Fig. 21) and the opener (②, Fig. 21) by means of movement of thread releasing shaft bushing (③, Fig. 20) to the right or to the left as may be required. The standard clearance between the two parts is 0.8mm as shown Fig. 21.
3. Tighten the screw (②, Fig. 20) securely.

II) Position of the opener cam:

Place the one of screws (④, Fig. 20) which is indicated by "S" on V ditch of the hook shaft.

III) Adjustment of operation: (Fig. 20 and 22)

1. Turn the machine pulley until the opener (①, Fig. 22) presses the projection of hook (②, Fig. 22) extremely on its travel.
2. Press the opener to the projection of hook and make the right side clearance between the notch on the bobbin case holder and the tab of the hook retainer (③, Fig. 22) 0.2mm as shown Fig. 22
3. This adjustment can be done by loosening the screw (⑤, Fig. 20)

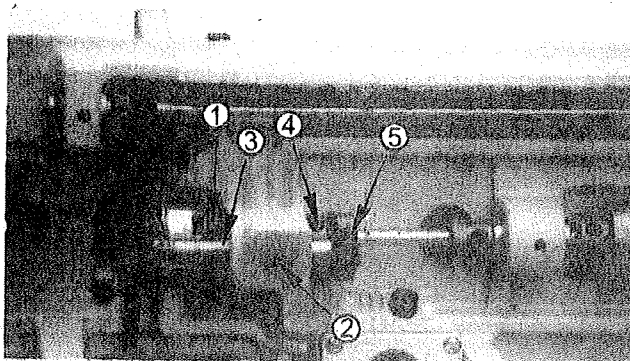

Fig.20

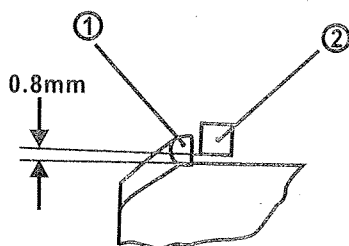

Fig.21

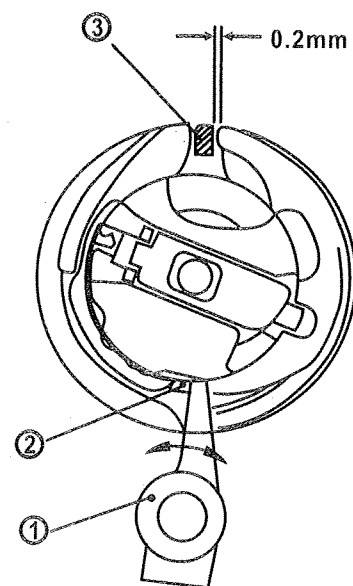

Fig.22

ADJUSTING THE HEIGHT OF THE PRESSER FEET

1. Adjustment by the presser bar lifter:

Loosen the screw (①, Fig.23) sufficiently, raise the presser bar lifter and loosen the set screw (②, Fig.23). Move the lifting presser foot (A, Fig.7) up or down as may be required so as to get the correct height and tighten the screws.

2. Adjusting the lift of alternating presser feet:

If the height of the lifting presser foot changes, the momentums of the lifting and vibrating presser foot vary, thus the height of the vibrating presser foot must be adjusted.

To adjust this, lower the presser bar lifter, holding the vibrating presser foot (B, Fig.7) and loosen the hexagon screw (③, Fig.23) and move the presser foot up or down as may be required. After setting the position, tighten the screw.

TIMING OF THE VIBRATING PRESSER FOOT

This is the normal timing when turn the machine pulley toward you, after lowering the presser bar lifter, the vibrating presser foot should reach the feeder earlier than the needle eye comes to, and when the needle raises, the vibrating presser foot should leave the feeder after the needle eye has left the feeder.

This is due to the reason that the vibrating presser foot must tightly hold the goods while the needle is passing the goods for avoiding irregular stitches.

To adjust this, set the lift of thre alternating presser feet to equal, loowen the two screws (④, Fig. 23) and adjust the rotating position of the cam (⑤, Fig.23) faster or slower as may be desired, and tighten the screws.

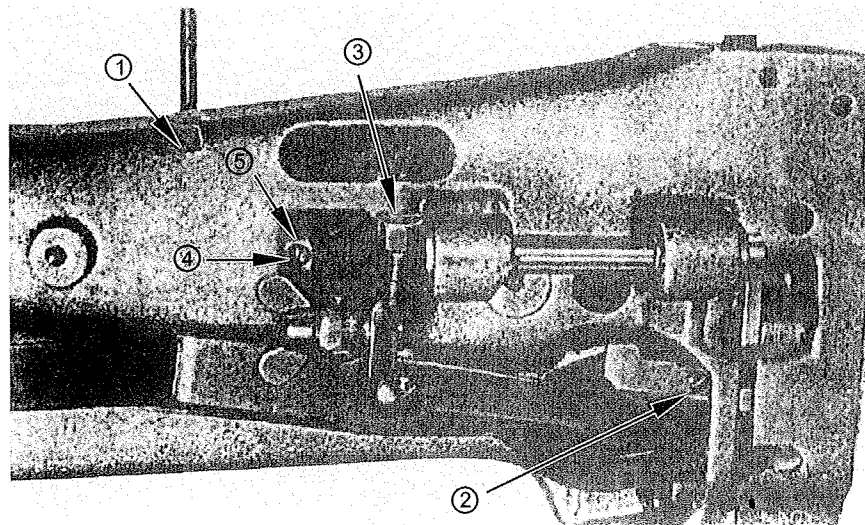

Fig. 23

ADJUSTMENT OF THE CLEARANCE BETWEEN FEED FORKED CONNECTION AND FEED FORK COLLAR

Incorrect clearance between the fork (④, Fig. 17) of feed forked connection and feed fork collar (⑤, Fig. 17) will bring irregular stitch length or overheating, etc. To adjust this, open the cover plate (①, Fig. 17).

1. To increase the clearance, loosen the screw (⑦, Fig. 17) and turn the screw (⑥, Fig. 17) to the left or counter-clockwise.
2. To decrease the clearance, loosen the screw (⑥, Fig. 17) and turn the screw (⑦, Fig. 17) to the right or clockwise.

This adjustment should be done with turning the machine pulley toward you to get correct clearance.

Upon completion of adjustment, tighten the screw which is loosened to touch the feed fork.

ADJUSTING THE THREAD CONTROLLER SPRING

Normally, the thread controller spring (①, Fig.24) should hold slack of the upper thread until the needle reaches to the goods, and it should pause while raising of the needle and passing of the upper thread through the bobbin case.

I) For more controller action on the thread:

Loosen the stop screw (②, Fig. 24), move the stop (③, Fig. 24) to the right (For less action, move it to the left). Tighten the screw.

II) To adjust the tension of the spring:

Loosen the serrated nut (④, Fig. 24) and the screw (⑤, Fig. 24).

Turn the tension stud (⑥, Fig.24) slightly to the left to strengthen the tension (to lighten the tension, turn to the right) with a screw driver. Tighten the screw and nut upon completion of adjustment.

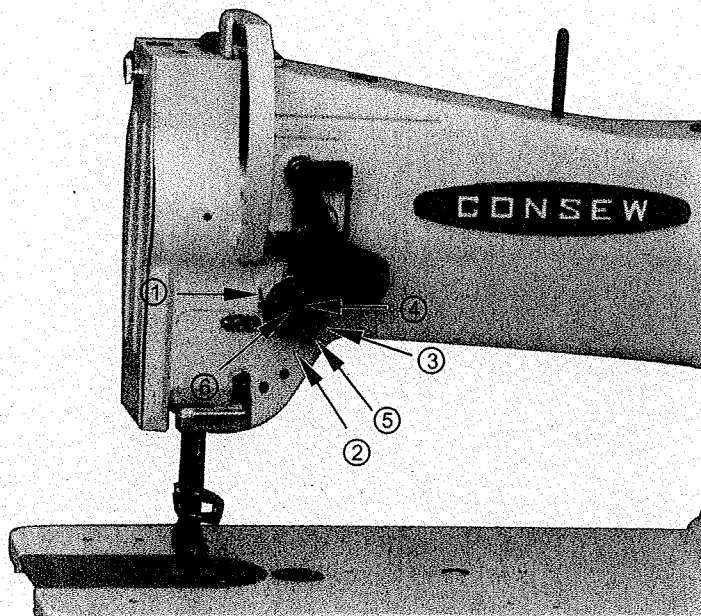

Fig. 24

ADJUSTMENT OF SPRING TENSION OF SAFETY CLUTCH (Fig.25)

The sewing hook and its mechanism are protected by a safety clutch. If it should become necessary to adjust the spring tension, use the following procedure:

1. Depress the button (E, Fig. 2) in the bed plate of the machine with your left hand. At the same time turn the machine pulley strongly so that the safety clutch disengages.
2. Lay down the machine head toward the other side. Hold the safety clutch (left) ① and turn the safety clutch (right) ② until you can see the screw ④ through the hole ③.
3. To strengthen the tension of spring ⑤, turn the screw ④ to the right, while to lighten the tension, turn the screw to the left.
4. Upon completion of adjustment, depress the button (E, Fig.2). At the same time turn the machine pulley until the safety clutch re-engages.

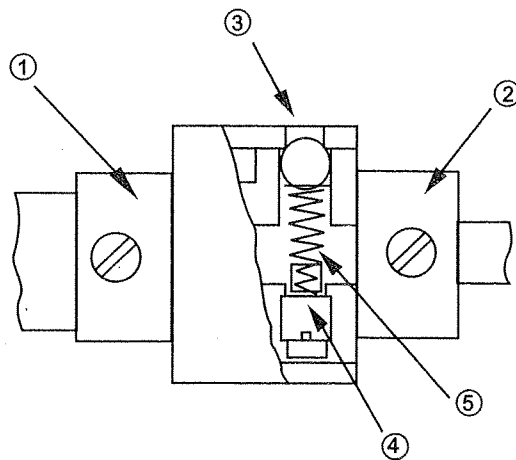

Fig. 25

SUPPLEMENTARY INFORMATION ON OILING FOR MODEL 206RB-1

For simplified lubrication the upper arm of the machine is fitted with a centralized lubricating system. Same is located beneath the arm top cover plate. Swing open this plate (Fig.I) and a felt-filled reservoir "R" will become visible. Before operating a new machine or one which has been standing idle for a prolonged period of time, soak these felt pads with oil until it will be noticed that they have become fully saturated and do not accept any additional quantities. After that the only attention required is a shot of oil into the holes in the arm top cover, whenever the machine is oiled as part of the daily routine.

An oil reservoir for lubrication the rotary sewing hook is provided at the underside of the machine bed. (Fig.II) Unscrew the filler plug and fill the reservoir with oil until it reaches the red "Full" line. Replace the filler plug and tighten it. The flow of oil to the hook can be regulated by means of the control valve "V". To increase oil flow, loosen the lock nut and turn screw counter-clockwise two or three turns. To reduce oil flow, loosen lock nut and tighten screw clockwise completely and back it off about 3 turns. To stop oil flow, if so required, just tighten screw. Be sure to tighten lock nut without changing setting of screw.

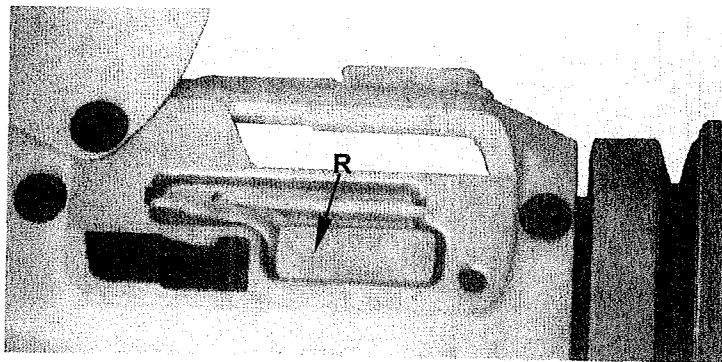

Fig.I

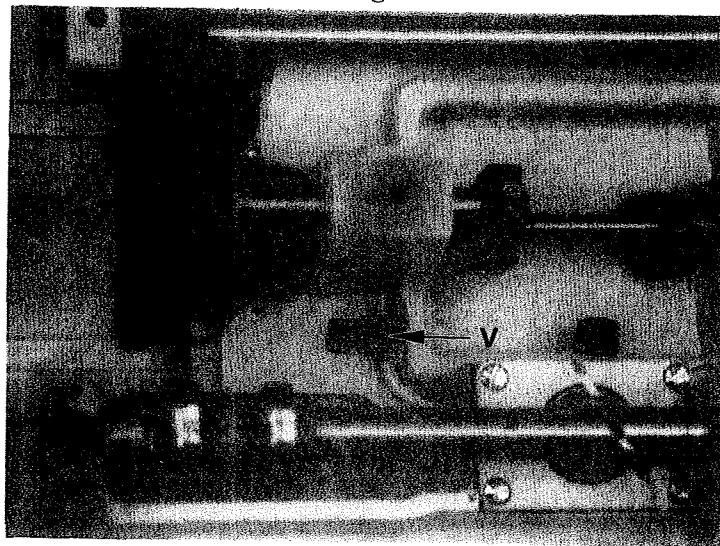

Fig.II

CONSOLIDATED SEWING MACHINE CORP.
131 WEST 25TH STREET, NEW YORK, NY 10001, U.S.A.