

Instruction book

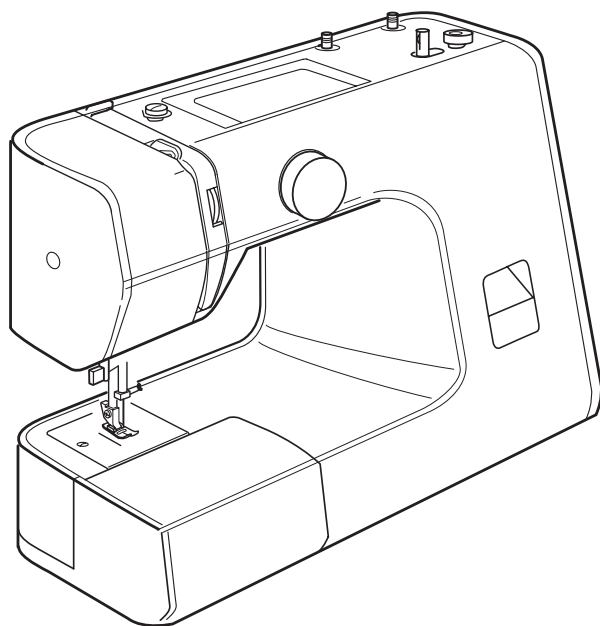

IMPORTANT SAFETY INSTRUCTIONS

This appliance is not intended for use by persons (including children) with reduced physical, sensory or mental capabilities, or lack of experience and knowledge, unless they have been given supervision or instruction concerning use of the appliance by a person responsible for their safety. Children should be supervised to ensure that they do not play with the appliance.

When using an electrical appliance, basic safety precautions should always be followed, including the following:

This sewing machine is designed and manufactured for household use only.

Read all instructions before using this sewing machine.

DANGER— To reduce the risk of electric shock:

1. An appliance should never be left unattended when plugged in. Always unplug this sewing machine from the electric outlet immediately after using and before cleaning.
2. Always unplug before replacing a sewing machine bulb. Replace bulb with same type rated 15 Watts.

WARNING— To reduce the risk of burns, fire, electric shock, or injury to persons:

1. Do not allow to be used as a toy. Close attention is necessary when this sewing machine is used by or near children.
2. Use this appliance only for its intended use as described in this owner's manual. Use only attachments recommended by the manufacturer as contained in this owner's manual.
3. Never operate this sewing machine if it has a damaged cord or plug, if it is not working properly, if it has been dropped or damaged, or dropped into water. Return this sewing machine to the nearest authorized dealer or service center for examination, repair, electrical or mechanical adjustment.
4. Never operate the appliance with any air opening blocked. Keep ventilation openings of this sewing machine and foot controller free from accumulation of lint, dust and loose cloth.
5. Never drop or insert any object into any opening.
6. Do not use outdoors.
7. Do not operate where aerosol (spray) products are being used or where oxygen is being administered.
8. To disconnect, turn all controls to the off ("O") position, then remove plug from outlet.
9. Do not unplug by pulling on cord. To unplug, grasp the plug, not the cord.
10. Keep fingers away from all moving parts. Special care is required around the sewing machine needle.
11. Always use the proper needle plate. The wrong plate can cause the needle to break.
12. Do not use bent needles.
13. Do not pull or push fabric while stitching. It may deflect the needle causing it to break.
14. Switch this sewing machine off ("O") when making any adjustment in the needle area, such as threading the needle, changing the needle, threading the bobbin or changing the presser foot, and the like.
15. Always unplug this sewing machine from the electrical outlet when removing covers, lubricating, or when making any other adjustments mentioned in this owner's manual.

SAVE THESE INSTRUCTIONS

 Please note that on disposal, this product must be safely recycled in accordance with relevant National legislation relating to electrical/electronic products. If in doubt please contact your retailer for guidance.
(European Union only)

TABLE OF CONTENTS

SECTION 1. NAMES OF PARTS

Names of Parts	2
Extension Table	3
Standard Accessories	3
Carrying Handle	3

SECTION 2. GETTING READY TO SEW

Connecting Machine to Power Supply	4
Before Using Your Sewing Machine	4
For Your Safety	4
Controlling Sewing Speed	4
Setting Spool Pins	5
Presser Foot Lifter	5
Changing Presser Foot.....	5
Changing Needles	6
To Check the Needle	6
Thread and Needle Chart.....	6
Bobbin Winding.....	7-8
Threading the Machine.....	9-10
Needle Threader.....	10
Balancing Needle Thread Tension.....	11
Stitch Pattern Selector.....	12
Stitch Chart Panel.....	12
Reverse Stitch Button	12
Darning Plate.....	12

SECTION 3. BASIC SEWING

Straight Stitch	13
To Change Sewing Direction	13
Seam Guide Lines	14
Turning a Square Corner	14
Basic Zigzag.....	14
Tricot Stitch	15
Buttonhole	16
Corded Buttonhole.....	17
Zipper Application.....	18
Pin Tucking	18
Free Hand Mending and Embroidery	19
Blind Hem Stitch	20

SECTION 4. DECORATIVE STITCHES

Shell Tuck	21
Applique.....	21
Decorative Stitch Pattern	22

SECTION 5. CARE OF YOUR MACHINE

Cleaning the Bobbin Case and the Shuttle Race	23
Cleaning the Feed Dog	23
Sewing Light.....	24
Troubleshooting	25

SECTION 1. NAMES OF PARTS

Names of Parts

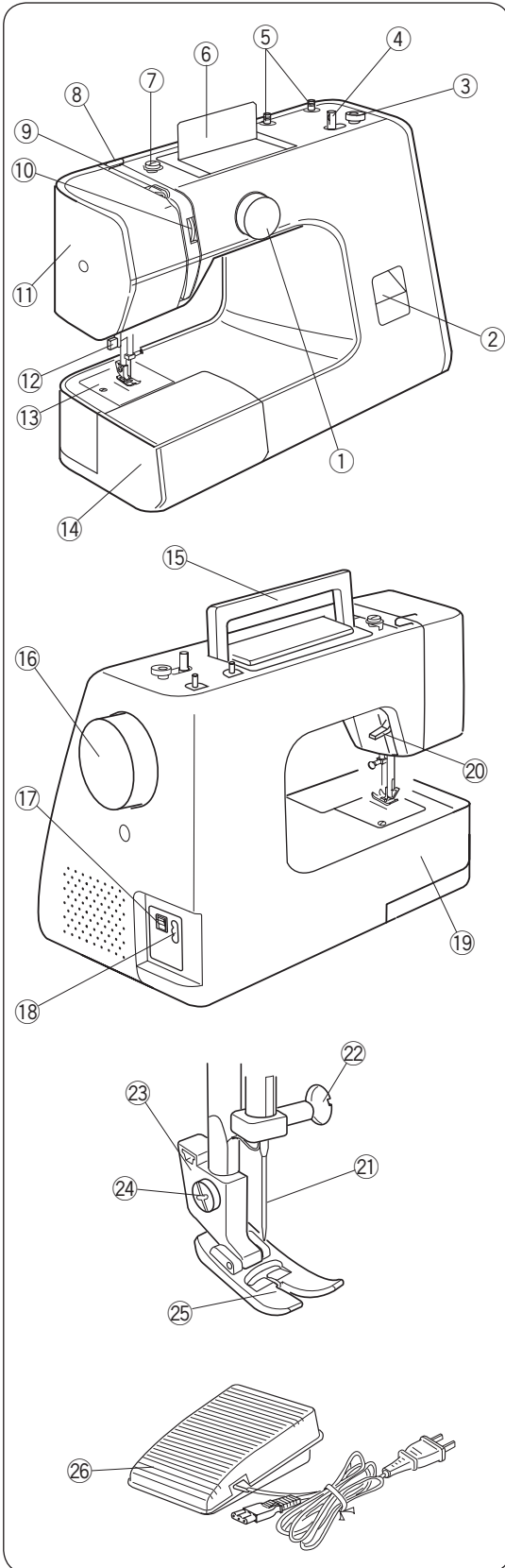

- ① Stitch pattern selector dial
- ② Reverse stitch control
- ③ Bobbin winder stopper
- ④ Bobbin winder spindle
- ⑤ Spool pins
- ⑥ Stitch chart panel
- ⑦ Bobbin winding tension disc
- ⑧ Thread guide
- ⑨ Thread take-up lever
- ⑩ Thread tension dial
- ⑪ Face cover
- ⑫ Needle threader
- ⑬ Needle plate
- ⑭ Extension table (Accessory box)
- ⑮ Carrying handle
- ⑯ Handwheel
- ⑰ Power switch
- ⑱ Machine socket
- ⑲ Free-arm
- ⑳ Presser foot lifter
- ㉑ Needle
- ㉒ Needle clamp screw
- ㉓ Presser foot holder
- ㉔ Setscrew
- ㉕ Presser foot
- ㉖ Foot control

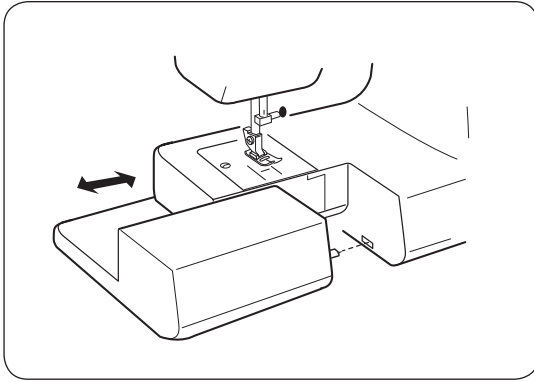

Extension Table

• Detaching the table

Pull the table away from the machine, as illustrated, for “free-arm” sewing of cuffs and sleeves. The extension table can be used as accessory box.

• Attaching the table

Push the extension table until it snaps into the machine.

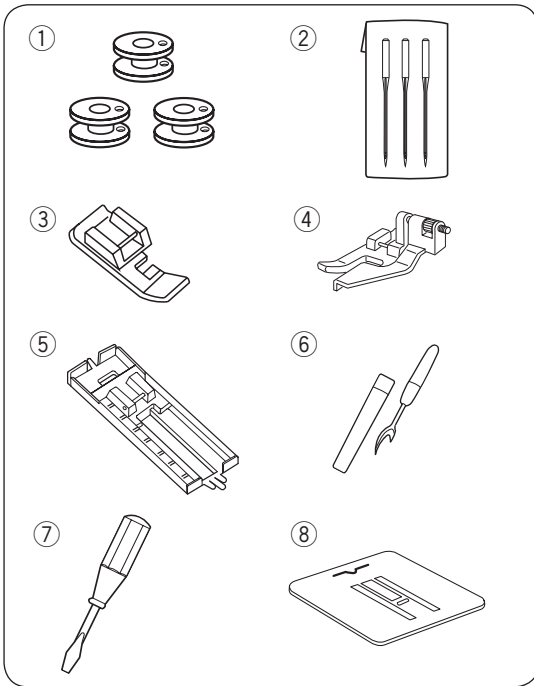

Standard Accessories

- ① Bobbins
- ② Needle set
- ③ Zipper foot
- ④ Blind hem stitch foot
- ⑤ Sliding buttonhole foot
- ⑥ Buttonhole opener / Seam ripper
- ⑦ Screwdriver (small)
- ⑧ Darning plate

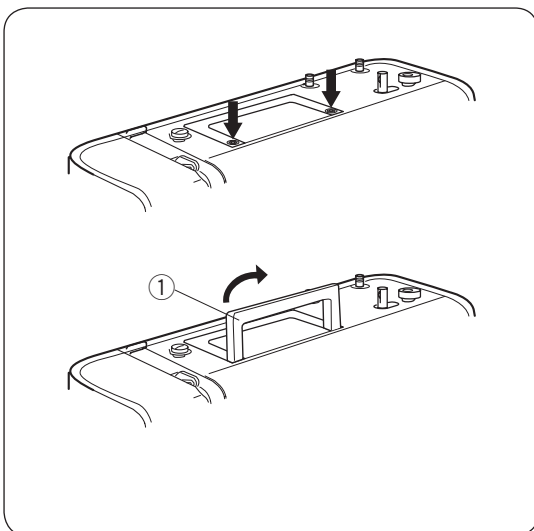

Carrying Handle

Press down the ☉ marks on the carrying handle to raise the carrying handle.

- ① Carrying handle

SECTION 2. GETTING READY TO SEW

Connecting Machine to Power Supply

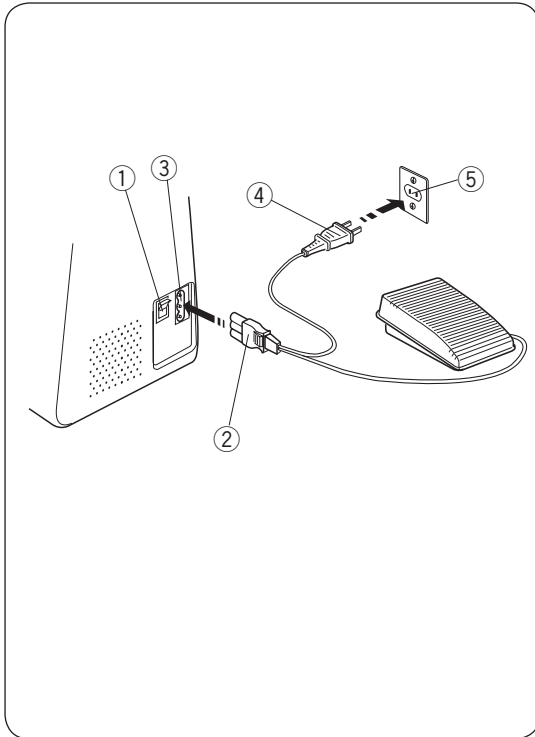

CAUTION:

Before connecting the power cord, make sure the voltage and frequency shown on the machine conform to your electrical power.

1. Turn off the power switch ①.
2. Insert the machine plug ② into the machine socket ③.
3. Insert the power supply plug ④ into the outlet ⑤.
4. Turn on the power switch ① to activate the power and sewing light.

- ① Power switch
- ② Machine plug
- ③ Machine socket
- ④ Power supply plug
- ⑤ Outlet

Before Using Your Sewing Machine

Before using your sewing machine for the first time, place a waste fabric under the presser foot and run the machine with thread for a few minutes. Wipe away any oil which may appear.

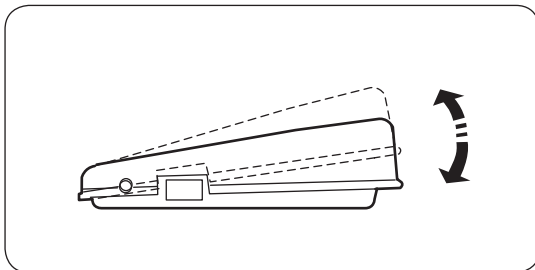

Operating Instructions (for the U.S.A and Canada only)

This appliance has a polarized plug (one blade wider than the other). To reduce the risk of an electric shock, this plug is intended to fit in a polarized outlet only one way. If the plug does not fit in the outlet, reverse the plug. If it still does not fit, contact a qualified electrician to install the proper outlet. Do not modify the plug in any way.

Foot Controller Model KD-1902 is used with this machine.

For Your Safety

- * While in operation, always keep your eyes on the sewing area. Do not touch any moving parts, such as the thread take-up lever, handwheel or needle.
- * Always turn off the power switch and unplug from the power supply:
 - When leaving the machine unattended
 - When attaching or removing any parts
 - When cleaning the machine
- * Do not place anything on the foot control, when not sewing.

Controlling Sewing Speed

Sewing speed can be varied by the foot control. The harder you press on the foot control, the faster the machine runs.

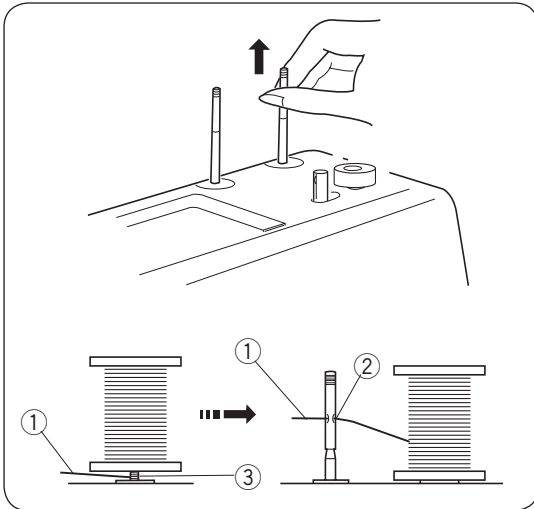

Setting Spool Pins

The spool pins are used for holding the spools of thread when feeding the thread to the machine.

To use, pull up the spool pins. Push down for storage.

- ① Upper thread
- ② Hole
- ③ Tangle

NOTE:

When using thread which has tendency to tangle around a spool pin ③, thread through the hole ② of spool pin as shown. The hole should face the thread spool.

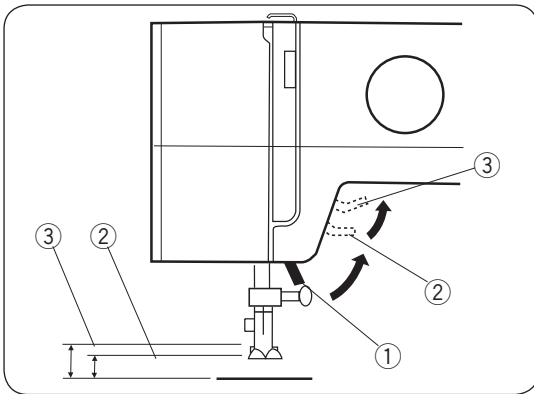

Presser Foot Lifter

The presser foot lifter raises and lowers the presser foot.

You can raise it about 1/4" (0.6 cm) higher than the normal up position to help place heavy fabric under the foot.

- ① Presser foot lifter
- ② Normal up position
- ③ Highest position

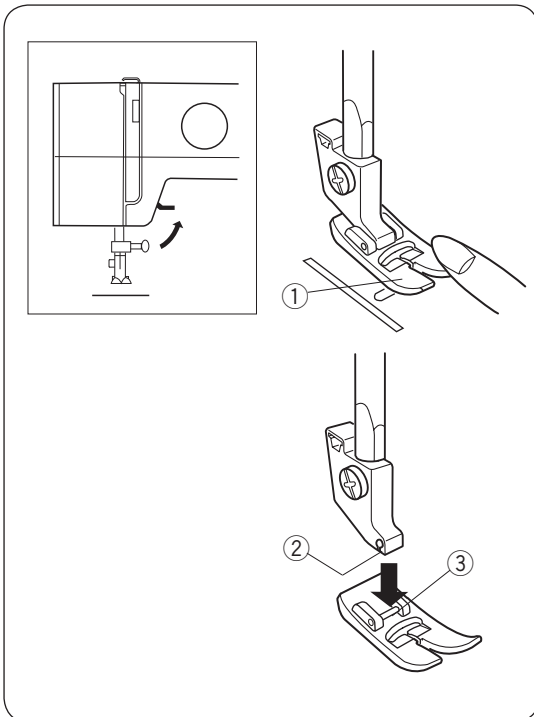

Changing Presser Foot

- ① Presser foot
- ② Groove
- ③ Pin

⚠ CAUTION:

When attaching or removing presser foot, turn OFF the power switch.

• To remove

Turn the handwheel toward you to raise the needle bar to its highest position.

Raise the presser foot.

Push the toe of the presser foot ① to snap it off the foot holder.

• To attach

Place the presser foot so that the pin ③ on the foot lines up directly below the groove ② of the foot holder.

Lower the foot holder to lock the foot in place.

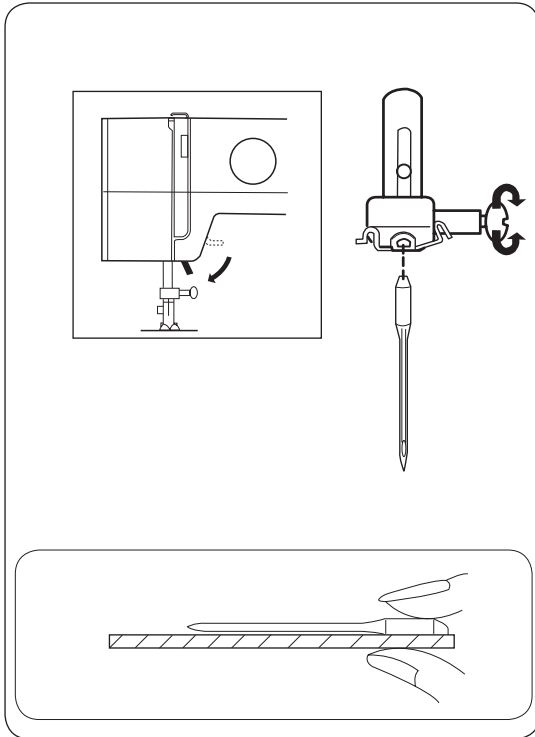

Changing Needles



CAUTION:

When changing needles, turn OFF the power switch.

Raise the needle by turning the handwheel toward you and lower the presser foot.

1 Loosen the needle clamp screw by turning it counterclockwise.

Remove the needle from the clamp.

2 Insert the new needle into the clamp with the flat side away from you.

When inserting the needle into the clamp, push it up as far as it will go and tighten the clamp screw firmly with the screw driver.

To Check the Needle

Place the flat side of the needle on something flat (needle plate, glass etc.). The clearance between the needle and flat surface should be consistent. Never use a bent or blunt needle.

Thread and Needle Chart

	Fabrics	Thread	Needle Size
Light weight	Crepe de Chine, Voile, Lawn, Organdy, Georgette, Tricot	Fine Silk Fine Cotton Fine Synthetic Fine Cotton Covered Polyester	65 (9) or 75 (11)
Medium weight	Linens, Cotton, Piqué, Serge, Double Knits, Percale	50 silk 50 to 80 Cotton 50 to 60 Synthetic Cotton Covered Polyester	75 (11) or 90 (14)
Heavy weight	Denim, Tweed, Gabardine, Suiting, Drapery and Upholstery Fabric	50 silk 40 to 50 Cotton 40 to 50 Synthetic Cotton Covered Polyester	90 (14) or 100 (16)

* In general, fine threads and needles are used for sewing thin fabrics, and thicker threads and needles are used for sewing heavy fabrics.

* Always test thread and needle size on a small piece of the fabric which will be used for actual sewing.

* Use the same thread for needle and bobbin.

* When sewing stretch, very fine fabrics and synthetics, use a stretch needle.

A stretch needle effectively prevents skipped stitches.

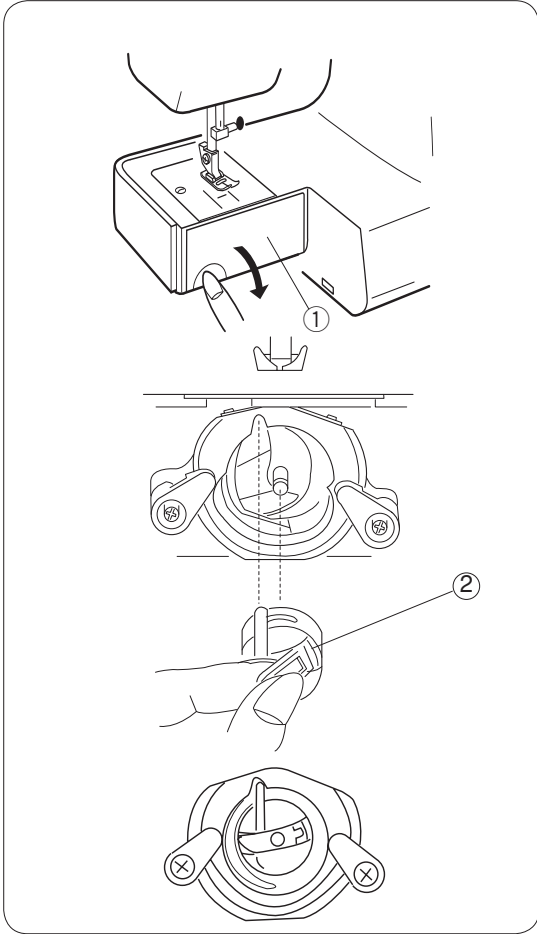

Bobbin Winding

• Removing bobbin case

Remove the extension table from the machine by pulling it to the left. Open the shuttle cover ① by pushing down the embossed part on the cover.

Raise the needle to its highest position by rotating the handwheel toward you.

① Shuttle cover

② Bobbin case

To remove the bobbin case ② from the shuttle, pull open the latch of the bobbin case. Pull the bobbin case straight out of the shuttle.

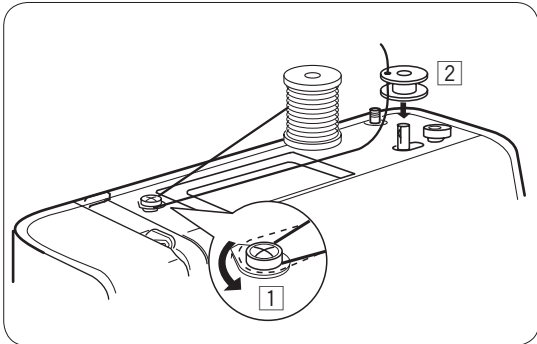

• Bobbin winding

① Draw thread from the spool.

Guide the thread around the thread guide.

② Thread through the hole in the bobbin from the inside to the outside.

Put the bobbin on the bobbin winder spindle.

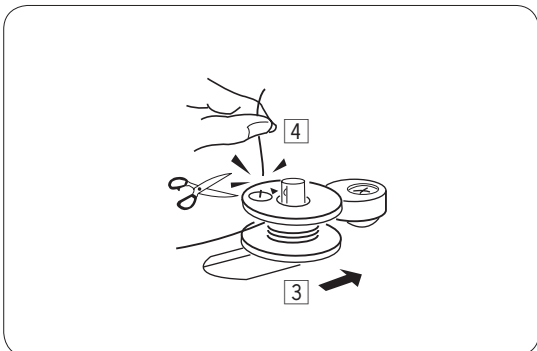

③ Push the bobbin to the right.

④ With the free end of the thread held in your hand, depress the foot control. Stop the machine when the bobbin has wound a few layers, and cut the thread close to the hole in the bobbin.

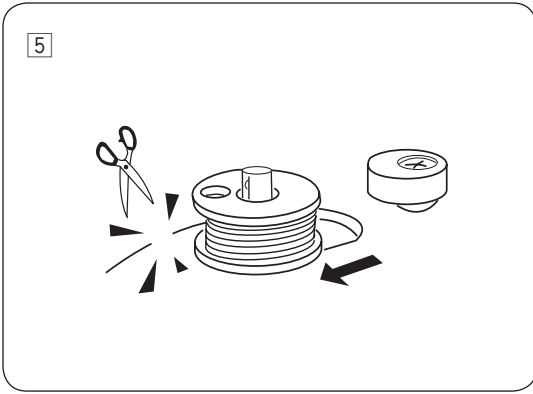

Bobbin winding (continued)

- 5 Depress the foot control again. When the bobbin is fully wound, it stops automatically. Return the bobbin winder to its original position by moving the spindle to the left, and cut the thread.

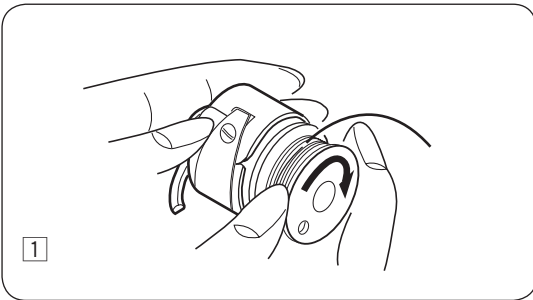

• Inserting bobbin

- 1 Place a bobbin in the bobbin case, making sure the thread feeds clockwise from the bobbin.



- 2 Draw the thread through the slot of the case.

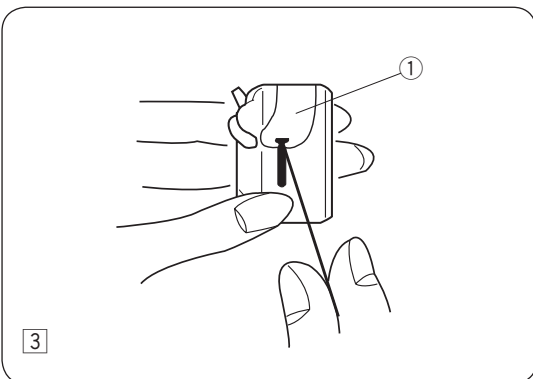

- 3 Continue to draw the thread under the tension spring ① and through the opening. Pull out about 4" (10 cm) of thread.
① Tension spring

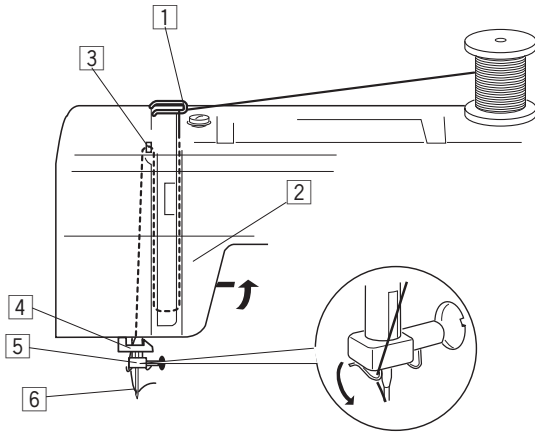

Threading the Machine

• Threading the machine

- * Raise the thread take-up lever to its highest position by turning the handwheel counterclockwise.
- * Raise the presser foot lifter.
- * Place a spool on the spool pin, with thread coming off as shown.

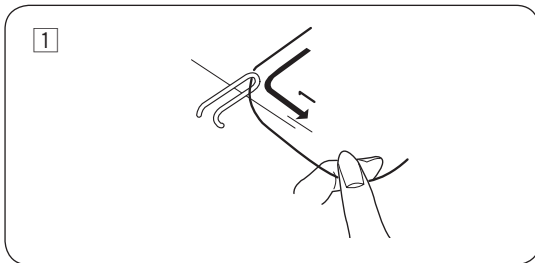

- 1 Draw the end of thread around the upper thread guide.

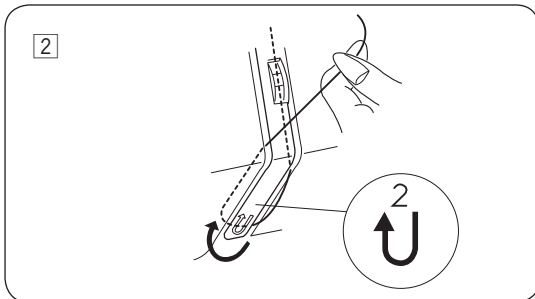

- 2 While holding the thread near the spool, draw the end of the thread down around the check spring holder.

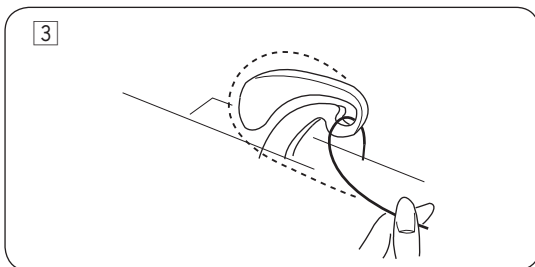

- 3 Firmly draw the thread up and from right to left over the take-up lever then down into the take-up lever eye.

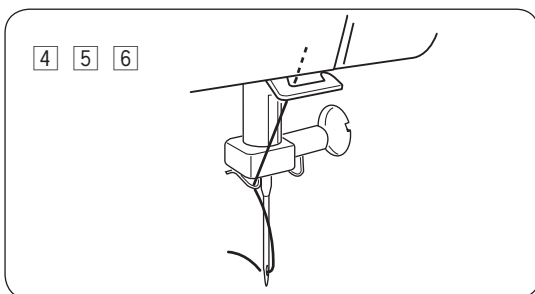

- 4 Then draw the thread down and slip it into the lower thread guide.

- 5 Draw the thread down and slip it into needle bar thread guide on the left.

- 6 Thread the needle eye from front to back.

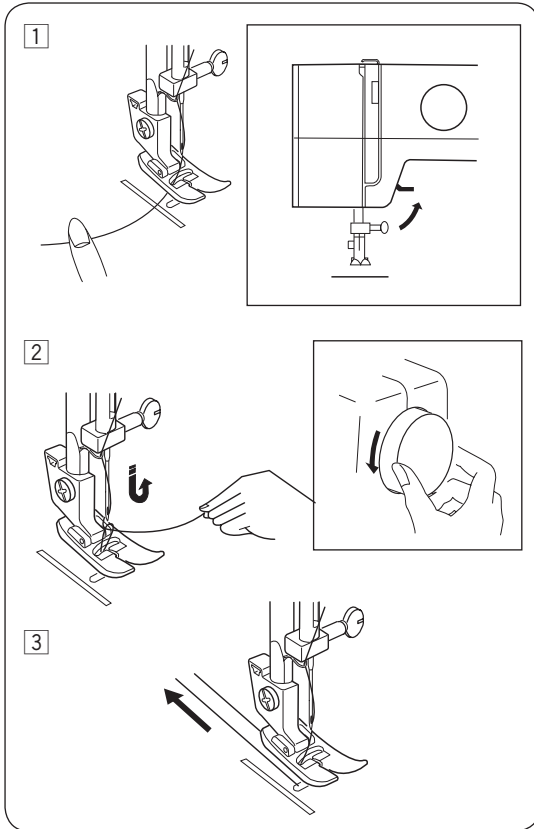

• Drawing up bobbin thread

- 1 Raise the presser foot. Hold the needle thread lightly with your left hand.
- 2 Rotate the handwheel counterclockwise, toward you, for one complete turn. Bring the bobbin thread up by pulling the needle thread up.
- 3 Pull both threads 4" to 6" (10.0 to 15.0 cm) under and behind the presser foot.

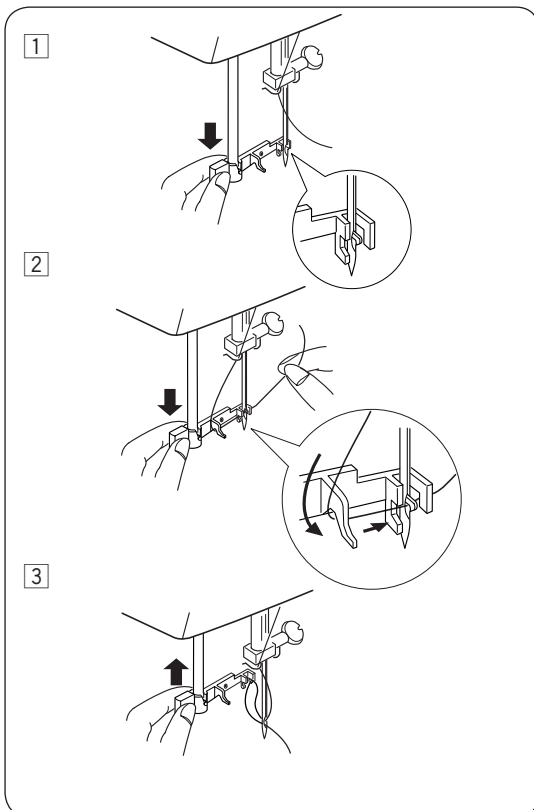

Needle Threader

- 1 Raise the needle to its highest position. Pull down the needle threader knob as far as it will go. The hook comes out through the needle eye from behind.
- 2 Lead the thread around the guide and under the hook.
- 3 Release the knob slowly while holding the thread end with your hand. A loop of the thread is pulled up through the needle eye.

* The needle threader can be used with a #11 to #16 needle or Blue tipped needle. Thread size 50 to 100 should also work well.

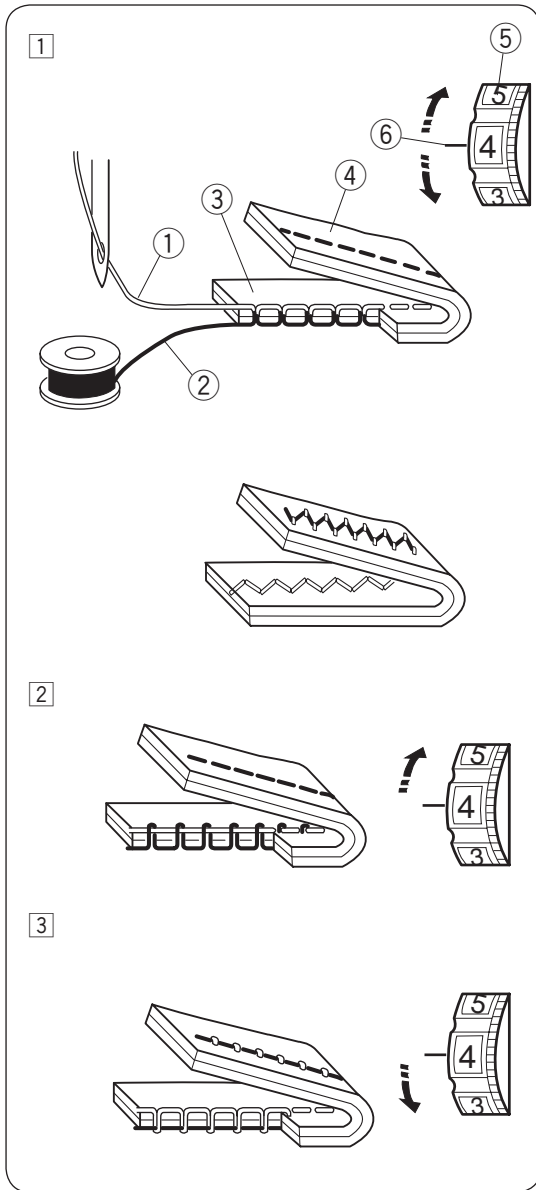

Balancing Needle Thread Tension

1 Correct tension

The thread tension is adjusted depending on the sewing materials, layers of fabric and sewing method.

The ideal straight stitch has threads locked between two layers of fabric as illustrated.

For an ideal zigzag stitch, the bobbin thread does not show on the right side (top side) of the fabric, and the needle thread shows slightly on the wrong side (bottom side) of the fabric.

- ① Needle thread (Top thread)
- ② Bobbin thread (Bottom thread)
- ③ Right side (Top side) of fabric
- ④ Wrong side (Bottom side) of fabric
- ⑤ Thread tension dial
- ⑥ Setting mark

2 Needle thread tension is too tight

When the bobbin thread (bottom thread) will appear on the right side (top side) of the fabric, Loosen the needle thread tension by moving the dial to a lower number.

3 Needle thread tension is too loose

When the needle thread (top thread) will appear on the wrong side (bottom side) of the fabric, tighten the needle thread tension by moving the dial to a higher number.

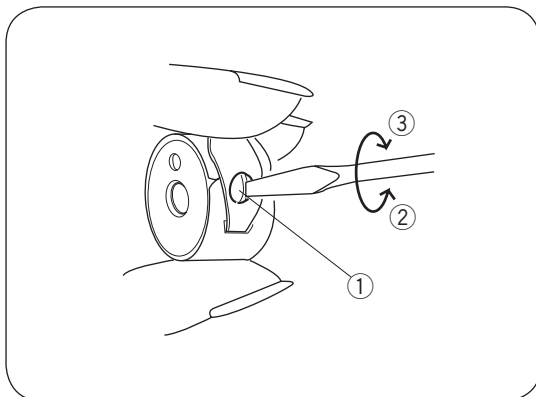

• Adjust bobbin tension

In some instances, you may need to adjust the bobbin thread tension.

Turn the adjusting screw ① in the direction of ② when the bobbin thread tension is too tight.

Turn the adjusting screw ① in the direction of ③ when the bobbin thread tension is too loose.

- ① Adjusting screw
- ② Decrease tension
- ③ Increase tension

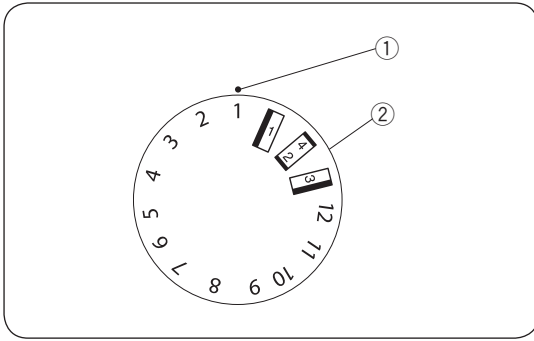

Stitch Pattern Selector

Raise the needle above the fabric.
Turn the dial to select the desired pattern.

- ① Setting mark
- ② Stitch selector

NOTE:

To avoid needle or fabric damage, make sure the needle is up and out of the fabric while selecting a stitch.

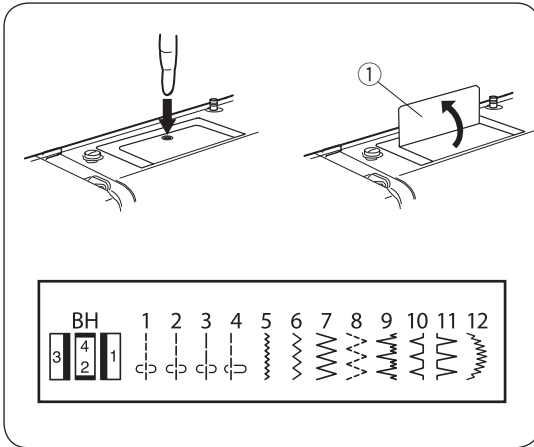

Stitch Chart Panel

Press down the ⊙ mark on the stitch chart panel to open it.

- ① Stitch chart panel

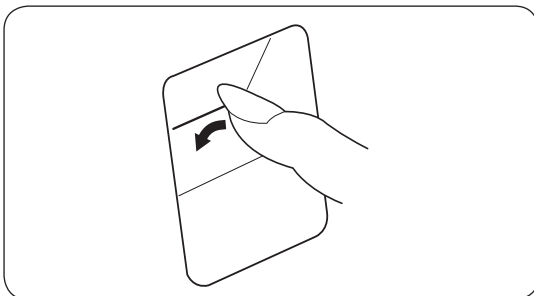

Reverse Stitch Button

As long as you keep the reverse stitch button depressed, the machines sew in backwards.

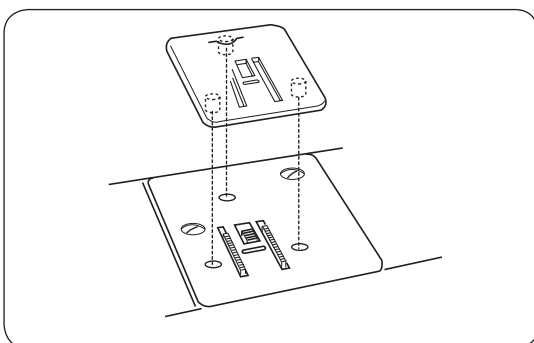

Darning Plate

Position the darning plate with 3 pins on the bottom.

Fit the darning plate pins into the needle plate holes. The feed dogs will show through the darning plate holes.

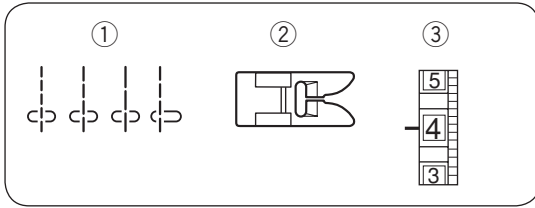

SECTION 3. BASIC SEWING

Straight Stitch

- ① Stitch pattern: 1 to 4
- ② Presser foot: Zigzag foot
- ③ Thread tension: 2 to 6

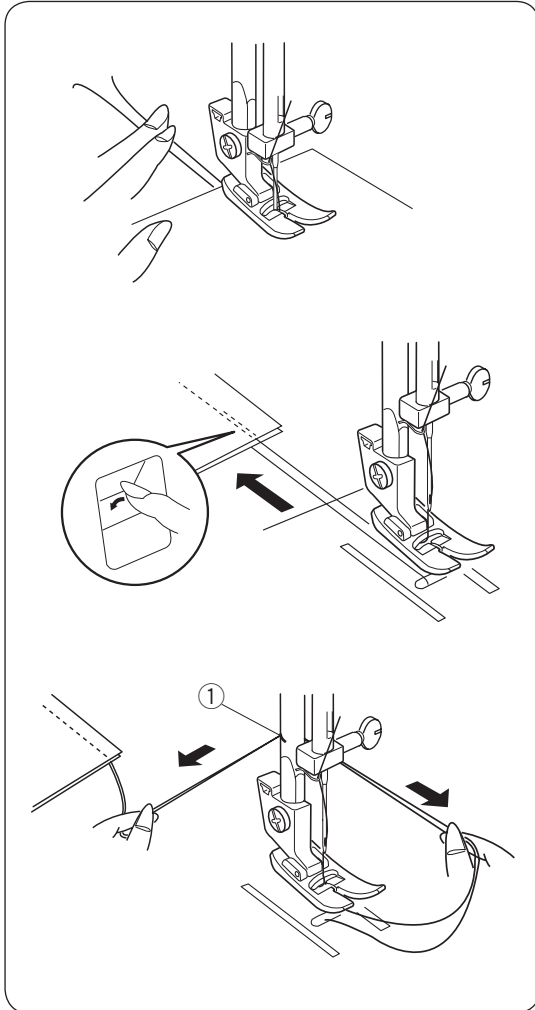

• Starting to sew

Raise the presser foot and position the fabric next to a seam guide line on the needle plate (5/8" [1.6 cm] is most common).

Lower the needle to the point where you want to start. Lower the presser foot and pull the threads toward the back. Depress the foot control.

Gently guide the fabric along a seam guide line letting the fabric feed naturally.

• Finishing sewing

To fasten the ends of a seam, press the reverse stitch control and sew several reverse stitches.

Raise the presser foot. Remove the fabric, draw the threads into the slit ① on the back of the presser bar and pull the threads to cut the threads as illustrated.

① Slit

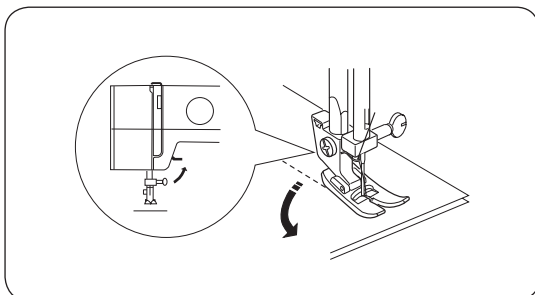

To Change Sewing Direction

Stop the machine and turn the handwheel toward you to bring the needle down into the fabric. Raise the presser foot.

Pivot the fabric around the needle to change sewing direction as desired.

Lower the presser foot and continue sewing.

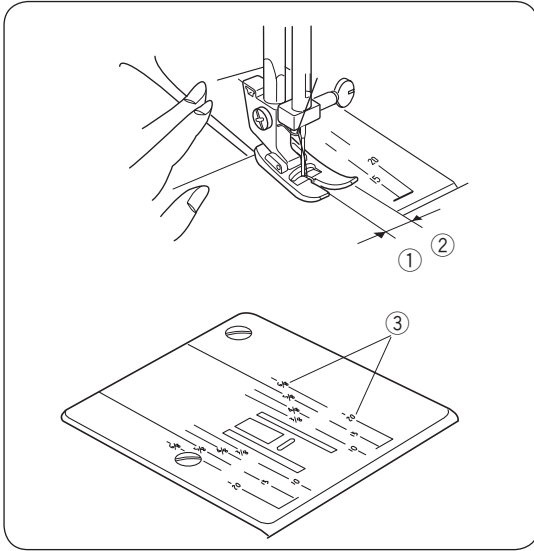

Seam Guide Lines

The numbers on the needle plate indicate the distance between the center needle position ① and the guideline ②.

The numbers in back are fractions of an inch.

The lines are 1/8" (0.3 cm) apart, and are engraved at 3/8", 4/8", 5/8" and 6/8".

The numbers in front are millimeters.

The lines are 5 mm apart, and are engraved at 10 mm, 15 mm and 20 mm.

- ① Center needle position
- ② Guide lines
- ③ Numbers

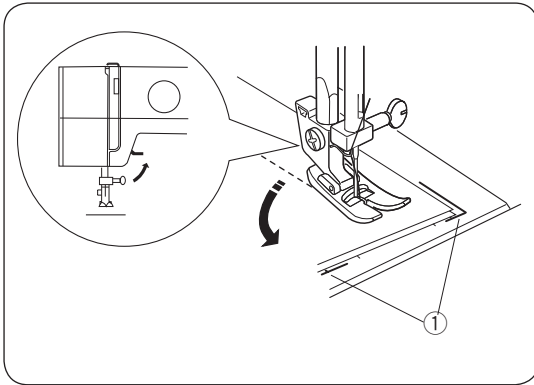

Turning a Square Corner

To turn a square corner 5/8" (1.6 cm) from the fabric edge.

Stop stitching and lower the needle by turning the handwheel counterclockwise.

Raise the presser foot and turn the fabric to line the edge with the 5/8" (1.6 cm) seam guide.

Lower the presser foot and begin stitching in the new direction.

- ① Cornering guide

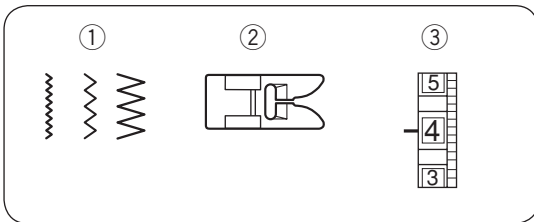

Basic Zigzag

- ① Stitch pattern: 5 to 7
- ② Presser foot: Zigzag foot
- ③ Thread tension: 2 to 5

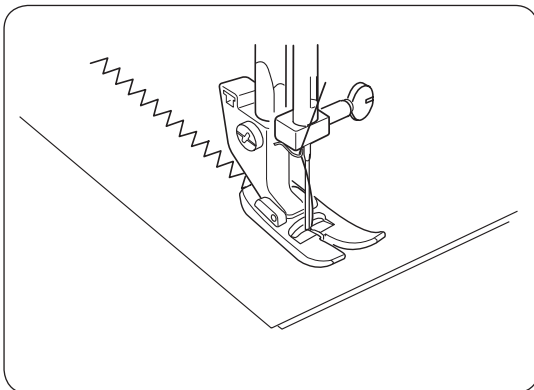

The zigzag stitch is one of the most common and versatile stitches. It can be a utility stitch for button sewing, buttonhole making, hemming, overcasting, mending and darning.

It can also be used to decorate with trims, appliques and cut work, or as a decorative stitch.

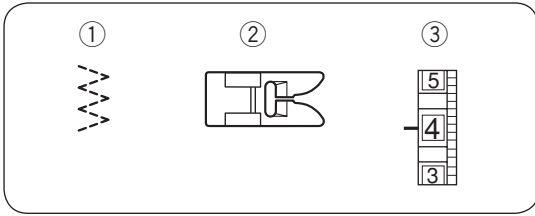

Tricot Stitch

- ① **Stitch pattern:** 8
- ② **Presser foot:** Zigzag foot
- ③ **Thread tension:** 1 to 4

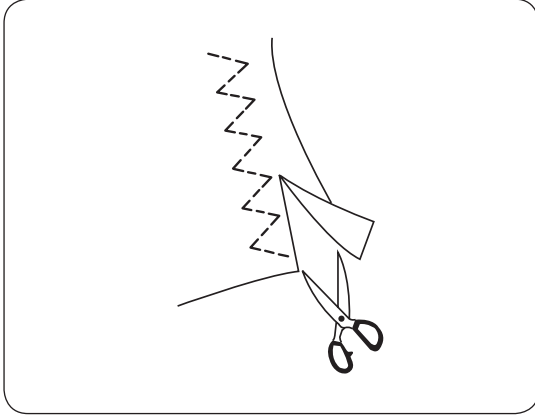

This stitch is used to finish the seam allowance on synthetics and other fabrics that tend to pucker. Place your fabric to allow a 5/8" (1.6 cm) seam. Trim the seam allowance after sewing.

Be careful not to cut the stitches.

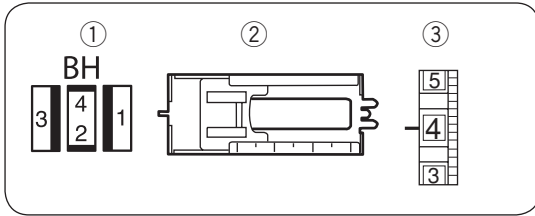

Buttonhole

- ① Stitch pattern: (BH)
- ② Presser foot: Sliding buttonhole foot
- ③ Thread tension: 1 to 5

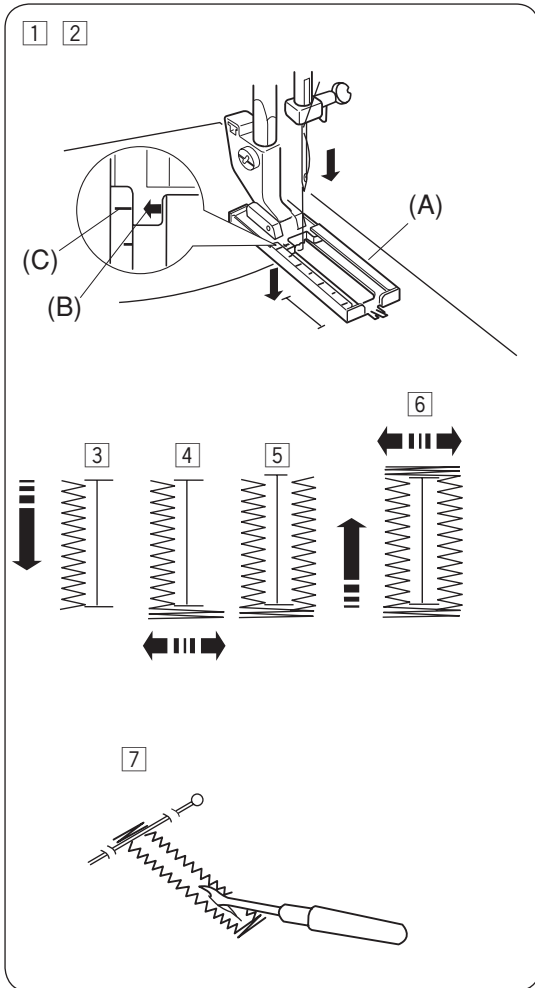

- ① Carefully mark buttonhole length on fabric. Place the fabric under the foot with the buttonhole marking running toward you.
- ② Move the slider (A) toward you so that the top mark (C) on the slider meets the start mark (B). Line up the markings on the foot with the top mark on the fabric.

Note:

The scale on the slider is engraved in centimeters.

- ③ Set the pattern selector dial at “”. Sew forward until you reach the front marking of your buttonhole. Stop sewing at a left stitch.
- ④ Set the pattern selector dial at “”. Sew 5 stitches. Stop sewing at a right stitch.
- ⑤ Set the pattern selector dial at “”. Sew until you reach the back marking of the buttonhole. Stop sewing at a right stitch.
- ⑥ Set the pattern selector dial at “”. Sew a few bartacks and raise the needle from the fabric. Set the pattern selector dial at a straight stitch. Sew a few locking stitches.
- ⑦ Remove the fabric from the machine and cut the sewing thread. Insert a pin inside the bartack. Then cut the opening with a seam ripper. Take care not to cut the stitches.

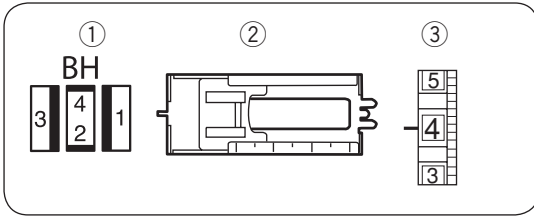

Corded Buttonhole

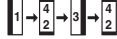
- ① Stitch pattern:  (BH)
 ② Presser foot: Sliding buttonhole foot
 ③ Thread tension: 1 to 5

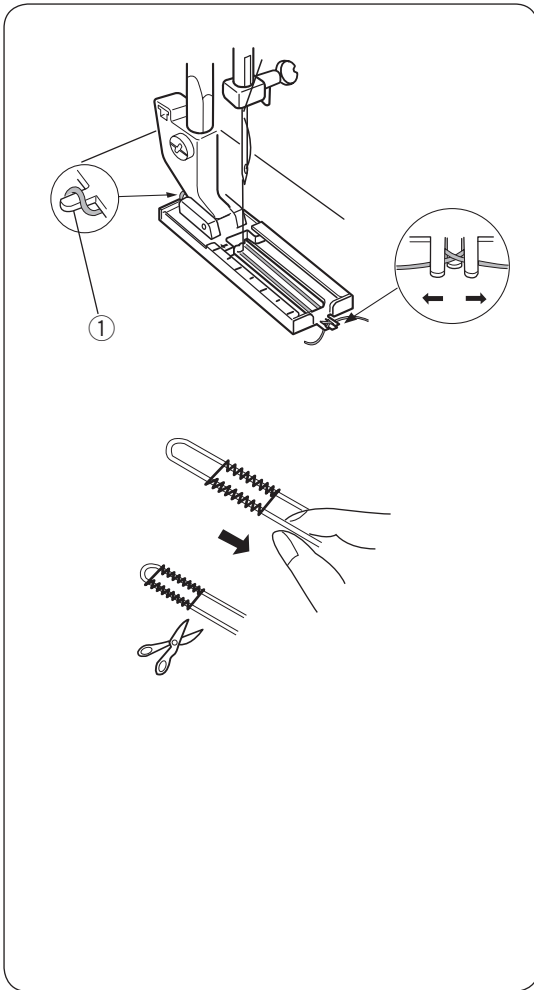

- 1 With the buttonhole foot raised, hook the cord on the cord spur at the back of the buttonhole foot.
 ① Spur
- 2 Bring the ends toward you under the buttonhole foot until they clear the front end.
- 3 Hook the filler cord into the forks on the front of the foot to hold them tight.
- 4 Lower the needle into the garment where the buttonhole will start and lower the foot.
- 5 Depress the foot control gently and sew the buttonhole. Each side of the buttonhole and the bartacks will be sewn over the cord.
- 6 Remove the fabric from the machine and cut the sewing threads.
- 7 Pull the left end of the filler cord to tighten it.
- 8 Thread the end through a darning needle, draw to the wrong side of the fabric and cut.

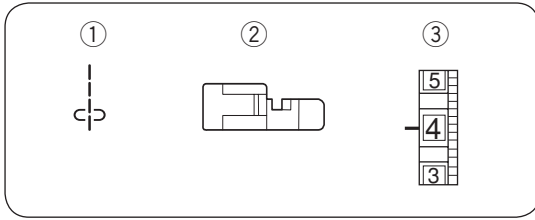

Zipper Application

- ① Stitch pattern: 1 to 3
- ② Presser foot: Zipper foot
- ③ Thread tension: 3 to 6

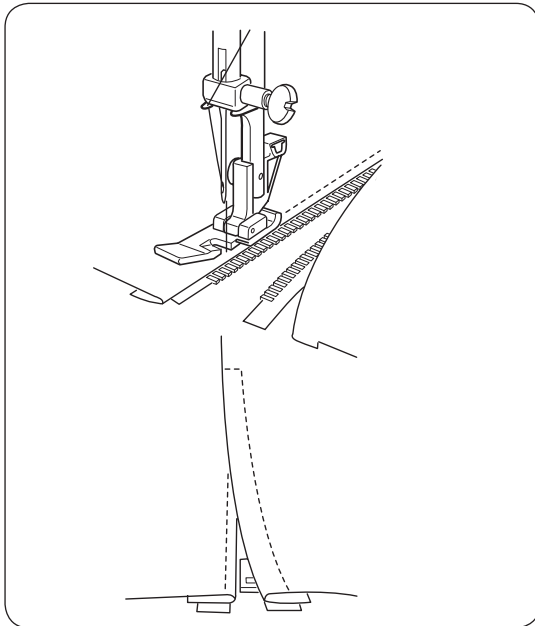

Pin or baste zipper tape to fabric and place it under the foot.

Smooth the threads toward the back and lower the foot.

To sew the left side of the zipper, guide the zipper teeth along the edge of the foot and stitch through the garment and zipper tape.

Turn the fabric and sew the other side of the zipper in the same way as you did the left side.

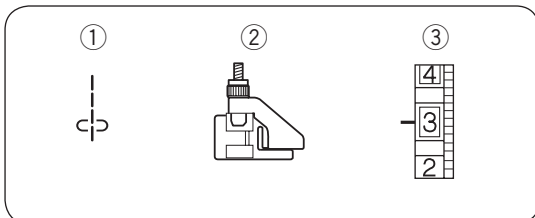

Pin Tucking

- ① Stitch pattern: 1 to 3
- ② Presser foot: Blind hem foot
- ③ Thread tension: 3 to 6

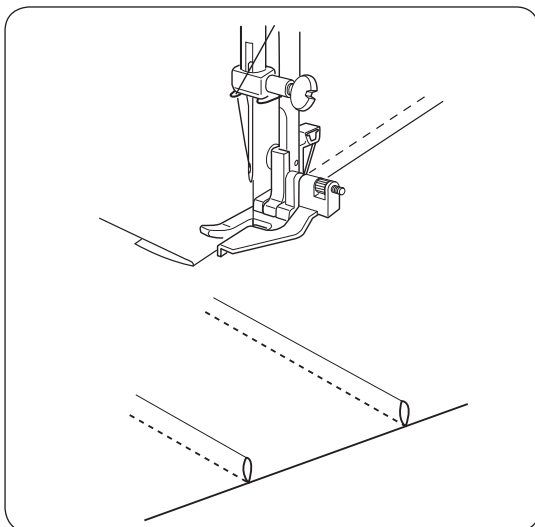

Fold the fabric wrong sides together and lower the needle into the fabric 1/16" (0.1 to 0.2 cm) inside the folded edge.

Lower the foot and turn the screw to align the guide on the foot with the folded edge.

Sew slowly while guiding the folded edge along the guide.

Open the fabric and iron press the tucks.

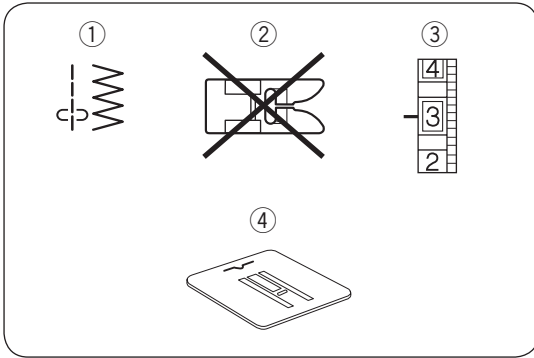

Free Hand Mending and Embroidery

- ① Stitch pattern: 1 to 7
- ② Presser foot: None
- ③ Thread tension: 2 to 6
- ④ Darning plate

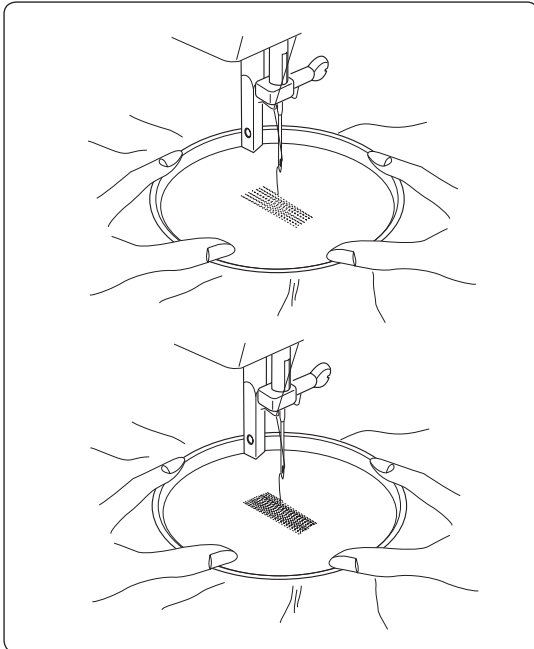

• Mending

Place the darning plate. Remove the foot holder and presser foot. Center the hole in the fabric on an embroidery hoop, as shown.

Lower the presser bar and sew at a slow speed.

Move the fabric back and forth slowly until the darning area is covered. Turn the fabric a 1/4 turn (90°), and sew another layer of stitching over the first layer.

NOTE:

If fabric is thin or badly damaged, attach a separate piece of fabric under the hole to reinforce it.

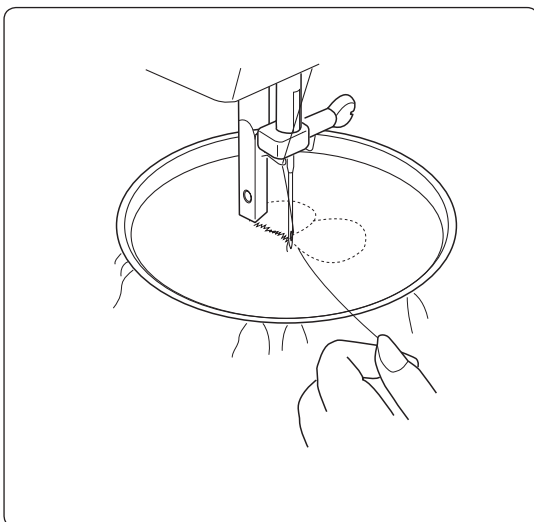

• Embroidery

Put on the darning plate.

Remove the foot holder and foot.

Adjust the stitch width.

Mark the drawing on the fabric with tailor's chalk.

Set fabric in the embroidery hoop and put it under the needle.

Lower the presser bar to engage upper thread tension. Holding upper thread with right hand, turn the handwheel toward you. Pull upper thread to let bobbin thread out of fabric.

At medium speed, stitch along the marked line.

After mending or embroidery sewing, remove the darning plate and put back the foot holder and foot.

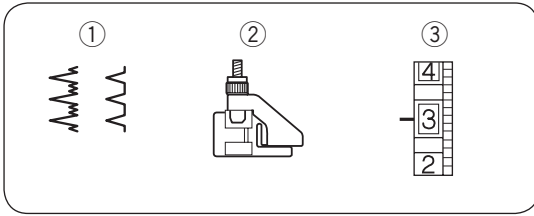

Blind Hem Stitch

- ① Stitch pattern: 9 or 10
- ② Presser foot: Blind hem foot
- ③ Thread tension: 2 to 4

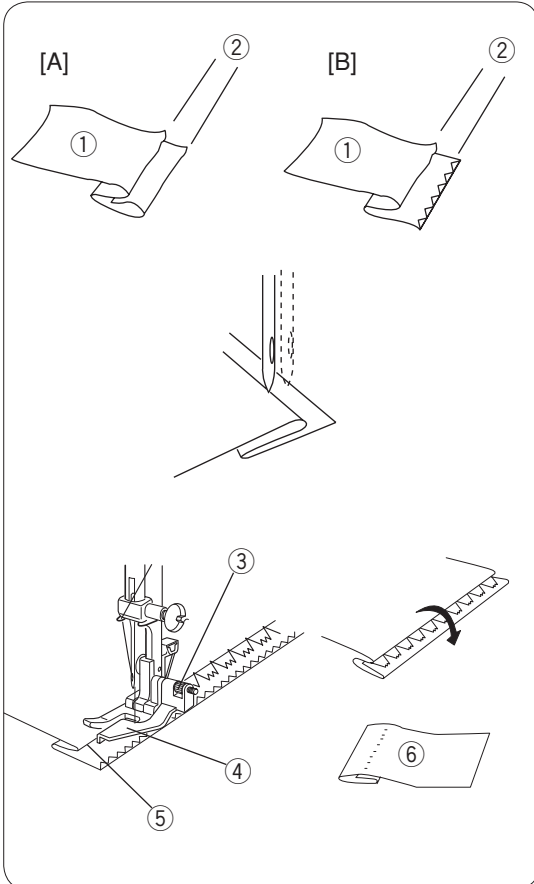

- ① Fold up the hem and fold it back to from a 1/4" (0.4 to 0.7cm) allowance as illustrated.

- ① Wrong side of the fabric
- ② 1/4" (0.4 to 0.7 cm)

- [A] Fold hem under the fabric for lightweight fabrics.

- [B] On heavy weight fabrics tend to ravel, the raw edge should be overcast first.

- ② Position the fabric so that the needle just pierces the edge of the fold when the needle swings to the extreme right. Lower the presser foot.

- ③ Turn the guide screw to adjust the guide aligning with the folded edge. Sew along the folded edge guiding the fabric so the needle catches the folded edge.

- ③ Guide screw
- ④ Guide
- ⑤ Folded edge

- ④ Open the fold flat.

- ⑥ Right side of the fabric

*If the needle drops far left, the stitches will show on the right side of the fabric.

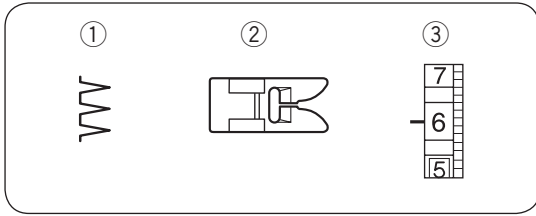

SECTION 4. DECORATIVE STITCHES

Shell Tuck

- ① Stitch pattern: 11
- ② Presser foot: Zigzag foot
- ③ Thread tension: 6 to 8

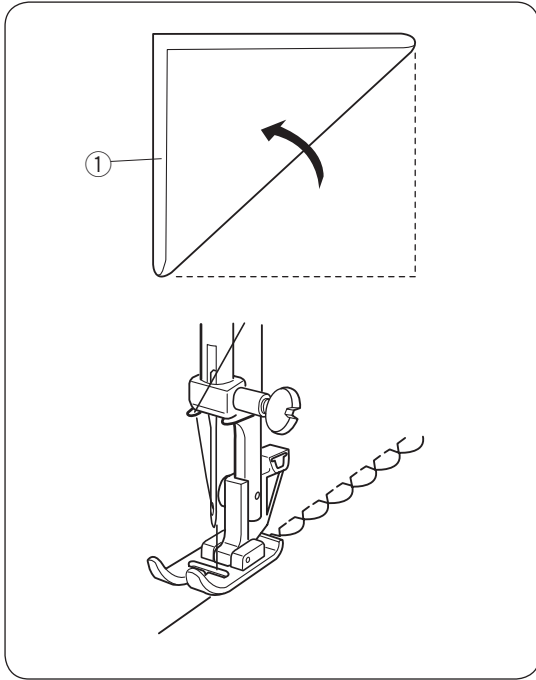

Use a lightweight fabric, such as tricot. Fold the fabric and stitch on the bias ①. You may need to increase the needle thread tension slightly. Allow the needle to just clear the folded edge of the fabric.

If you sew rows of shell stitches, space the rows at least 5/8" (1.5 cm) apart. You can also sew shell stitches on knits or soft silky woven fabrics in any direction.

- ① Bias

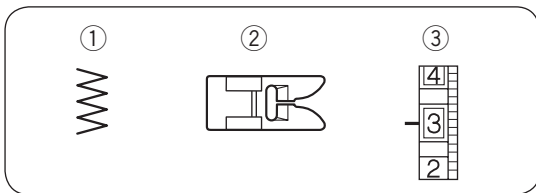

Applique

- ① Stitch pattern: 7
- ② Presser foot: Zigzag foot
- ③ Thread tension: 1 to 4

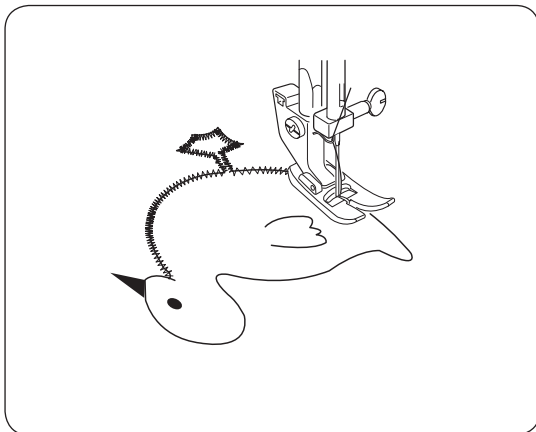

Baste applique pieces on the fabric, or fuse the applique pieces with an iron-on fabric joiner. Stitch around the applique, making sure the needle falls along the raw edge.

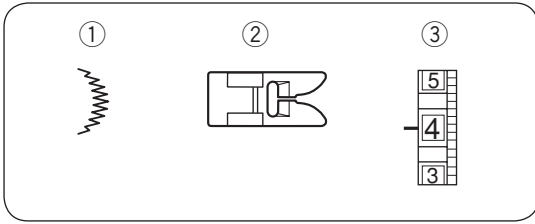

Decorative Stitch Pattern

- ① Stitch pattern: 12
- ② Presser foot: Zigzag foot
- ③ Thread tension: 1 to 4

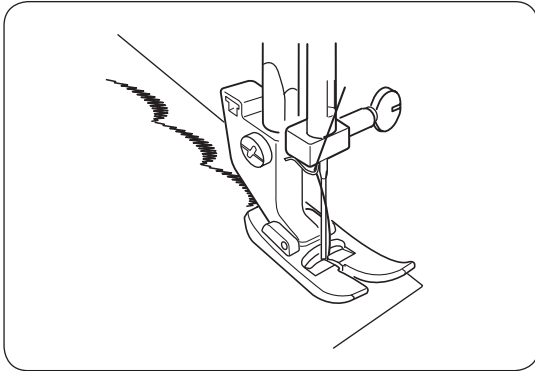

For a delicate appearance on fabric such as chiffon, use a single layer with a tear-away backing, if necessary.

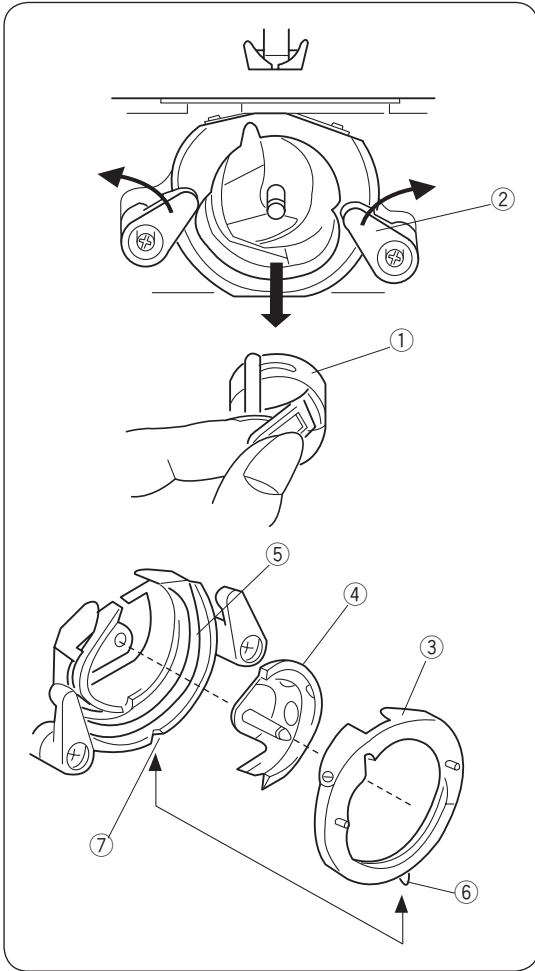

SECTION 5. CARE OF YOUR MACHINE

Cleaning the Bobbin Case and the Shuttle Race



CAUTION:

Turn off the power switch and unplug the machine before dismantling the sewing machine.

• To dismantle shuttle race unit:

Raise the needle to its highest position and open the shuttle cover.

Open the hinged latch of bobbin case and take it out of the machine.

Open the shuttle race ring holders and remove the shuttle race ring.

Remove the shuttle.

* Clean the shuttle race with a brush and a soft dry cloth.

- ① Bobbin case
- ② Shuttle race ring holder
- ③ Shuttle race ring
- ④ Shuttle
- ⑤ Shuttle race

• To assemble shuttle race unit:

Hold the shuttle by the center pin and fit it carefully back into the shuttle race, forming a perfect circle with the shuttle driver.

Attach the shuttle race ring making sure the bottom pin fits into the notch.

Lock the shuttle race ring by turning the holders back into position. Insert the bobbin case.

- ⑥ Pin
- ⑦ Notch

Cleaning the Feed Dog



CAUTION:

Turn off the power switch and unplug the machine before cleaning the feed dog.

Remove the needle and the presser foot.

Remove the needle plate setscrews and the needle plate.

- ① Setscrew

With a brush, clean out any dust and lint clogging the feed dog teeth.

Reset the needle plate.

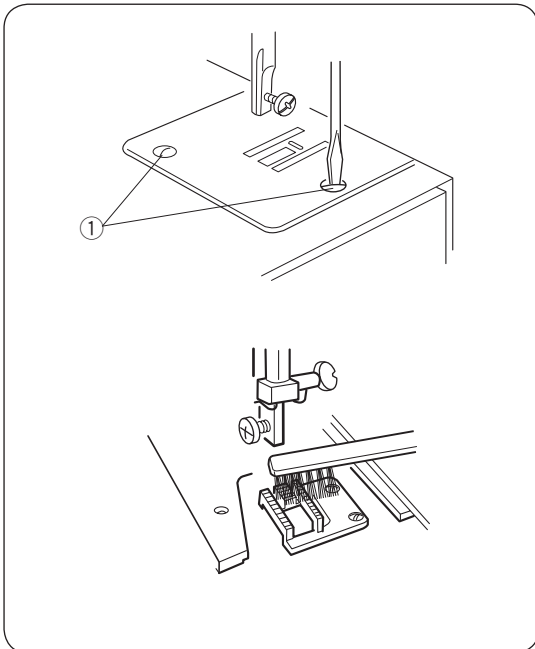

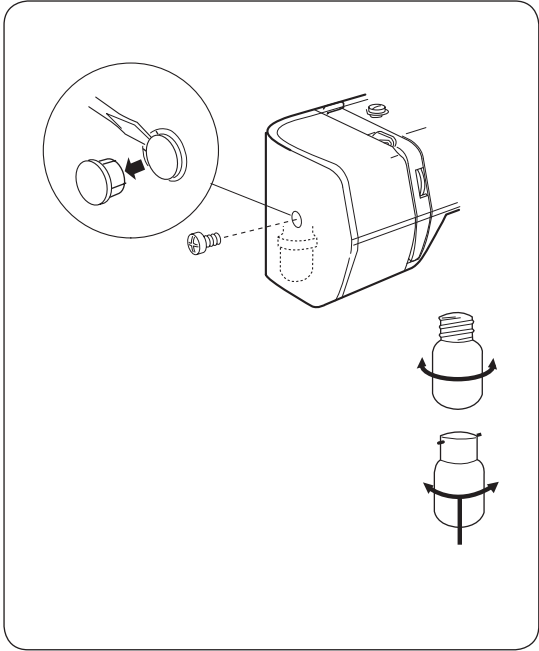

Sewing Light

The sewing light is located behind the face cover.

To change the bulb, take the face cover off the sewing machine by removing the cap and the setscrew.

Unplug the power supply before changing the bulb.

Do not dismantle the machine other than explained in this manual.

To remove Push and twist to the left.

To replace Push and twist to the right.

	WARNING The bulb may be HOT. Protect your fingers when handling it.
---	---

Troubleshooting

Condition	Cause	Reference
The needle thread breaks.	<ol style="list-style-type: none"> 1. The needle thread is not threaded properly. 2. The needle thread tension is too tight. 3. The needle is bent or blunt. 4. The needle is incorrectly inserted. 5. The needle thread and the bobbin thread are not set properly under the presser foot at the beginning of sewing. 6. The threads are not drawn to the rear after previous sewing. 7. The thread is too heavy, or too fine for the needle. 	<p>Page 9 Page 11 Page 6 Page 6 Pages 10, 13 Page 13 Page 6</p>
The bobbin thread breaks.	<ol style="list-style-type: none"> 1. The bobbin thread is not threaded properly in the bobbin case and shuttle. 2. Lint has collected in the shuttle area. 3. The bobbin is damaged and doesn't turn smoothly. 	<p>Page 8, 10 Page 23 Change the bobbin</p>
The needle breaks.	<ol style="list-style-type: none"> 1. The needle is incorrectly inserted. 2. The needle is bent or blunt. 3. The needle clamp screw is loose. 4. The needle thread tension is too tight. 5. The threads are not drawn to the rear after the previous sewing. 6. The needle is too fine for the fabric being sewn. 	<p>Page 6 Page 6 Page 6 Page 11 Pages 10, 13 Page 6</p>
Skipped stitches	<ol style="list-style-type: none"> 1. The needle is incorrectly inserted. 2. The needle is bent or blunt. 3. The needle and/or threads are not suitable for the work being sewn. 4. The needle thread is not threaded properly. 5. The wrong needle is being used. 	<p>Page 6 Page 6 Page 6 Page 9 Change the needle</p>
Seam puckering	<ol style="list-style-type: none"> 1. The needle thread tension is too tight. 2. The needle thread is not threaded properly. 3. The needle is too heavy for the fabric being sewn. 4. The stitch length is too long for the fabric. 	<p>Page 11 Page 9 Page 6 Make stitch shorter</p>
The cloth is not feeding smoothly.	<ol style="list-style-type: none"> 1. The feed dog is packed with lint. 2. The stitches are too fine. 	<p>Page 23 Make stitch longer</p>
The machine doesn't work.	<ol style="list-style-type: none"> 1. The machine is not plugged in. 2. A thread is caught in the shuttle race. 	<p>Page 4 Page 23</p>
Noisy operation	<ol style="list-style-type: none"> 1. A thread is caught in the shuttle race. 2. Lint has built up in the shuttle or the shuttle race. 	<p>Page 23 Page 23</p>

