

Instruction Manual

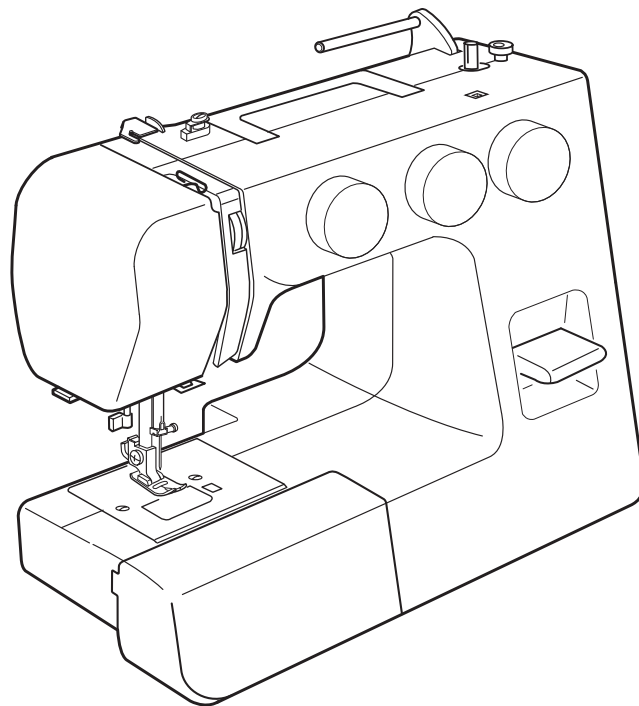

IMPORTANT SAFETY INSTRUCTIONS

When using an electrical appliance, basic safety precautions should always be followed, including the following:

This sewing machine is designed and manufactured for household use only.

Read all instructions before using this sewing machine.

DANGER— To reduce the risk of electric shock:

1. An appliance should never be left unattended when plugged in. Always unplug this sewing machine from the electric outlet immediately after using and before cleaning.

WARNING— To reduce the risk of burns, fire, electric shock, or injury to persons:

1. Do not allow to be used as a toy. Close attention is necessary when this sewing machine is used by or near children.
2. Use this appliance only for its intended use as described in this owner's manual. Use only attachments recommended by the manufacturer as contained in this owner's manual.
3. Never operate this sewing machine if it has a damaged cord or plug, if it is not working properly, if it has been dropped or damaged, or dropped into water. Return this sewing machine to the nearest authorized dealer or service center for examination, repair, electrical or mechanical adjustment.
4. Never operate the appliance with any air opening blocked. Keep ventilation openings of this sewing machine and foot controller free from accumulation of lint, dust and loose cloth.
5. Never drop or insert any object into any opening.
6. Do not use outdoors.
7. Do not operate where aerosol (spray) products are being used or where oxygen is being administered.
8. To disconnect, turn all controls to the off ("O") position, then remove plug from outlet.
9. Do not unplug by pulling on cord. To unplug, grasp the plug, not the cord.
10. Keep fingers away from all moving parts. Special care is required around the sewing machine needle and/or cutting blade.
11. Always use the proper needle plate. The wrong plate can cause the needle to break.
12. Do not use bent needles.
13. Do not pull or push fabric while stitching. It may deflect the needle causing it to break.
14. Switch this sewing machine off ("O") when making any adjustment in the needle area, such as threading the needle, changing the needle, threading the bobbin or changing the presser foot, and the like.
15. Always unplug this sewing machine from the electrical outlet when removing covers, lubricating, or when making any other adjustments mentioned in this owner's manual.

SAVE THESE INSTRUCTIONS

For Europe only:

This appliance can be used by children aged from 8 years and above and persons with reduced physical, sensory or mental capabilities or lack of experience and knowledge if they have been given supervision or instruction concerning use of the appliance in a safe way and understand the hazards involved. Children shall not play with the appliance. Cleaning and user maintenance shall not be made by children without supervision.

For outside Europe (except U.S.A and Canada):

This appliance is not intended for use by persons (including children) with reduced physical, sensory or mental capabilities, or lack of experience and knowledge, unless they have been given supervision or instruction concerning use of the appliance by a person responsible for their safety.

Children should be supervised to ensure that they do not play with this appliance.



Please note that on disposal, this product must be safely recycled in accordance with relevant National legislation relating to electrical/electronic products. If in doubt please contact your retailer for guidance.

■ (European Union only)

TABLE OF COTENTS

SECTION 1. KNOW YOUR MACIHNE

| | |
|----------------------------|---|
| Names of Parts..... | 2 |
| Setting the Spool Pin..... | 2 |
| Standard Accessories..... | 3 |
| Extension Table | 3 |

SECTION 2. GETTING READY TO SEW

| | |
|--|----|
| Connecting the Power Supply | 4 |
| Controlling the Sewing Speed | 5 |
| Reverse Stitch Lever..... | 5 |
| Dropping the Feed Dog | 5 |
| Raising and Lowering the Presser Foot..... | 6 |
| Changing the Presser Foot..... | 6 |
| Removing and Attaching the Foot Holder | 6 |
| Changing Needles | 7 |
| Fabric and Needle Chart | 7 |
| Winding the Bobbin | 8 |
| Removing the Bobbin | 8 |
| Winding the Bobbin | 9 |
| Inserting the Bobbin | 10 |
| Threading the Machine..... | 11 |
| Needle Threader | 12 |
| Drawing up the Bobbin Thread..... | 12 |
| Selecting the Stitch Pattern | 13 |
| Stitch Length Dial | 13 |
| Stitch Width Dial | 13 |
| Balancing Needle Thread Tension..... | 14 |

SECTION 3. BASIC SEWING

| | |
|-------------------------------------|----|
| Straight Stitch Sewing | 15 |
| Changing the Sewing Direction | 15 |
| Use the Seam Guide | 16 |
| Turning a Square Corner | 16 |
| Variable Needle Position..... | 16 |

SECTION 4. UTILITY STITCHES

| | |
|--|-------|
| Basic Zigzag | 17 |
| Overcasting | 17 |
| Tricot Stitch (Multiple Zigzag Stitch) | 18 |
| Knit Stitch | 18 |
| Straight Stretch Stitch..... | 19 |
| Zigzag Stretch Stitch | 19 |
| Button Sewing | 20 |
| 4-Step Buttonhole..... | 21 |
| Corded Buttonhole..... | 22 |
| Zipper Application..... | 23-25 |
| Blind Hemming | 26 |

SECTION 5. DECORATIVE STITCHES

| | |
|-----------------------------------|----|
| Shell Tuck | 27 |
| Smocking..... | 27 |
| Applique..... | 28 |
| Pin Tucking | 28 |
| Satin Stitches..... | 29 |
| Decorative Stretch Stitches | 29 |

SECTION 6. CARE AND MAINTENANCE

| | |
|--|----|
| Cleaning the Hook Race and Feed Dog..... | 30 |
| Replacing the Bobbin Holder..... | 31 |
| Troubleshooting | 32 |

SECTION 1. KNOW YOUR MACHINE

Names of Parts

- ① Bobbin winder stopper
- ② Bobbin winder spindle
- ③ Spool pin
- ④ Bobbin winder thread guide
- ⑤ Thread guide
- ⑥ Thread take-up lever
- ⑦ Face plate
- ⑧ Thread cutter
- ⑨ Needle threader
- ⑩ Needle plate
- ⑪ Extension table (Accessory storage)
- ⑫ Hook cover plate
- ⑬ Hook cover plate release button
- ⑭ Thread tension dial
- ⑮ Reverse stitch lever
- ⑯ Stitch width dial
- ⑰ Stitch length dial
- ⑱ Pattern selector dial
- ⑲ Presser foot
- ⑳ Needle
- ㉑ Needle clamp screw
- ㉒ Foot holder
- ㉓ Setscrew
- ㉔ Carrying handle
- ㉕ Handwheel
- ㉖ Power switch
- ㉗ Machine socket
- ㉘ Drop feed lever
- ㉙ Free-arm
- ㉚ Presser foot lifter

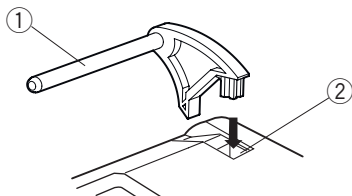
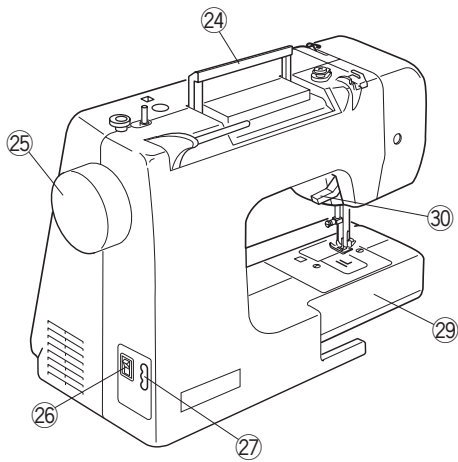
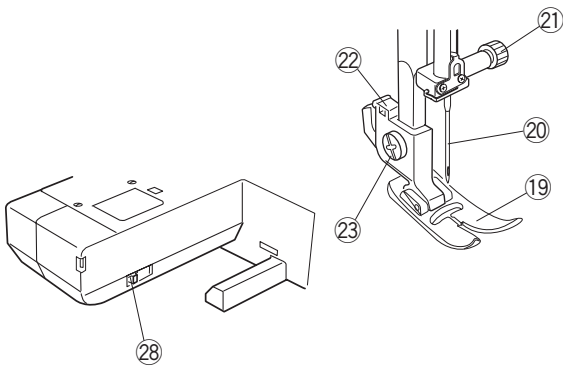
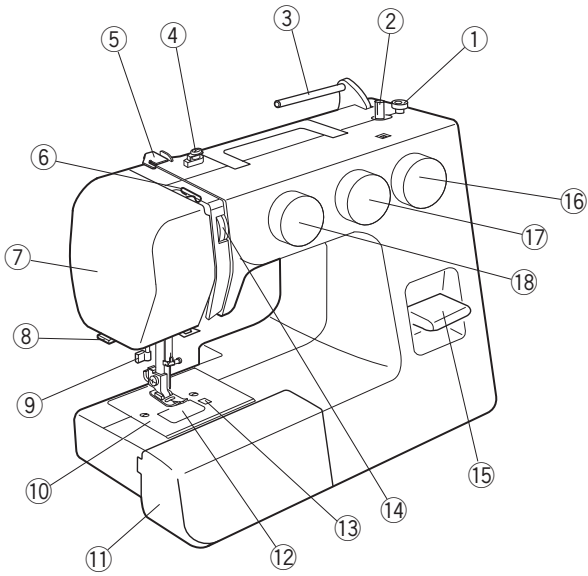

Setting the Spool Pin

Insert the spool pin into the hole as shown.

- ① Spool pin
- ② Hole

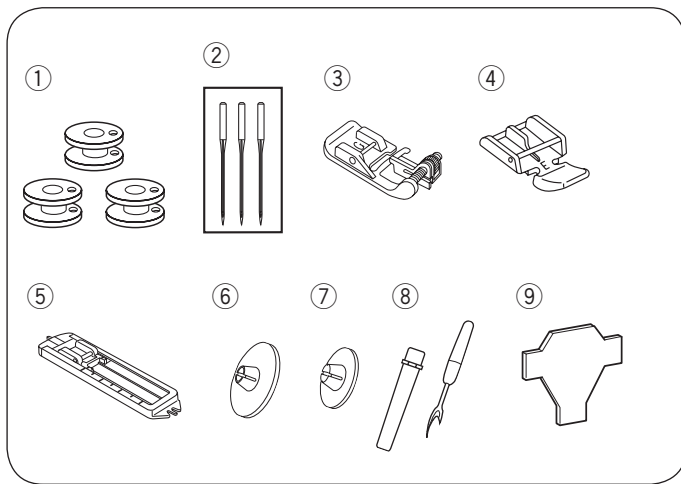

Standard Accessories

- ① Bobbins
- ② Needle set
- ③ Blind hemming foot G
- ④ Zipper foot E
- ⑤ Sliding buttonhole foot J
- ⑥ Spool holder (large)
- ⑦ Spool holder (small)
- ⑧ Seam ripper (buttonhole opener)
- ⑨ Screwdriver

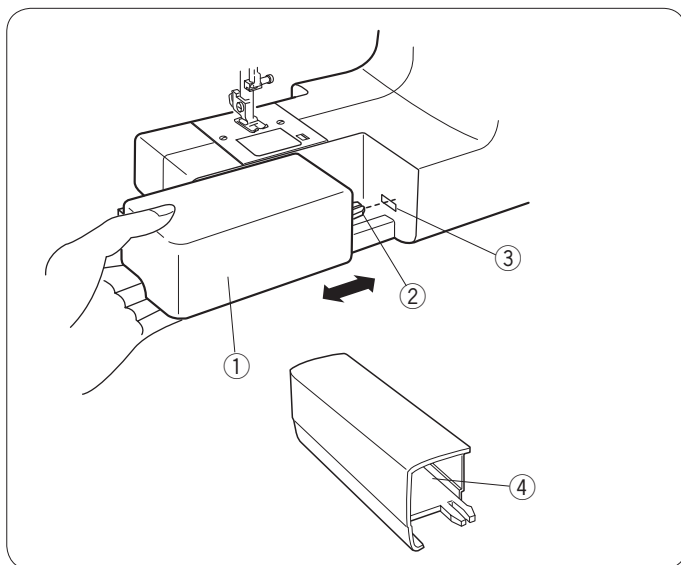

Extension Table

The extension table provides an extended sewing area and can be easily removed for free arm sewing. The accessories can be stored in the table.

Detaching the table:

Pull the table away from the machine, as illustrated.

Attaching the table:

Push the extension table, inserting the tab into the slot until the table snaps into the machine.

- ① Extension table
- ② Tab
- ③ Slot
- ④ Accessory storage

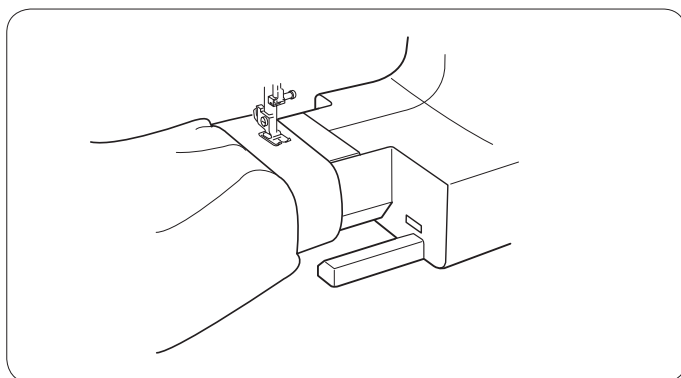

Free-arm sewing

Free-arm sewing is used for stitching sleeves, waistbands, pant legs or any other tubular garments. It is also useful for darning socks or mending knees or elbows.

SECTION 2. GETTING READY TO SEW

Connecting the Power Supply

- 1 Turn the power switch off.
 - 2 Insert the machine plug into the machine socket.
 - 3 Insert the power supply plug into the wall outlet.
 - 4 Turn the power switch on.
- ① Power switch
 - ② Machine plug
 - ③ Machine socket
 - ④ Power supply plug
 - ⑤ Wall outlet

NOTE:

Before connecting to the power supply, make sure the voltage shown on the machine conforms to your electrical power.

WARNING:

While in operation, always keep your eyes on the sewing area, and do not touch any moving parts such as the thread take-up lever, handwheel or needle. Always turn off the power switch and unplug from the power supply:

- when leaving the machine unattended.
- when attaching or removing parts.
- when cleaning the machine.

Do not place anything on the foot control, otherwise the machine will run intermittently.

Operating Instructions:

The symbol "O" of a switch indicates the "off" position of a switch.

For an appliance with a polarized plug (one blade wider than the other):

To reduce the risk of electrical shock, this plug is intended to fit in a polarized outlet only one way.

If it does not fit fully in the outlet, reverse the plug. If it still does not fit, contact a qualified electrician to install the proper outlet. Do not modify the plug in any way.

The foot controller Model YC-482J-EC or TJC-150 is used with this sewing machine (USA market only).

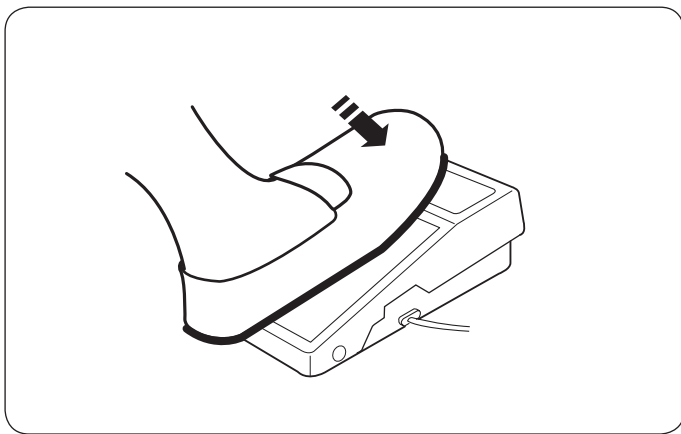

Controlling the Sewing Speed

Foot control

Sewing speed can be varied by the foot control. The harder you depress the foot control, the faster the machine runs.

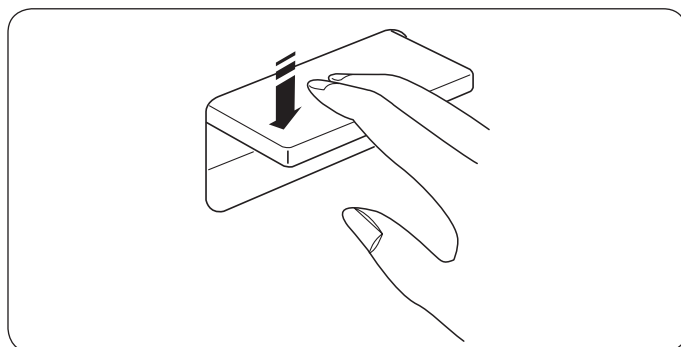

Reverse Stitch Lever

Push the reverse stitch lever down to sew in reverse. The machine will sew in reverse while the lever is pushed.

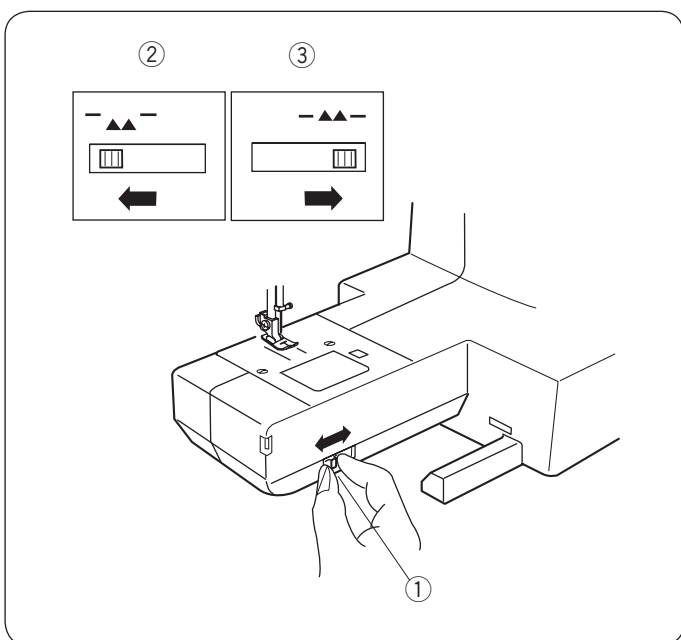

Dropping the Feed Dog

The drop feed lever is located underneath the free-arm bed on the front side of the machine.

To drop the feed dog, push the lever in the direction of the arrow, as illustrated.

To raise the feed dog, push the lever in the direction of the arrow, as illustrated, and turn the handwheel toward you.

The feed dog must be up for regular sewing.

- ① Drop feed lever
- ② Raised position
- ③ Lowered position

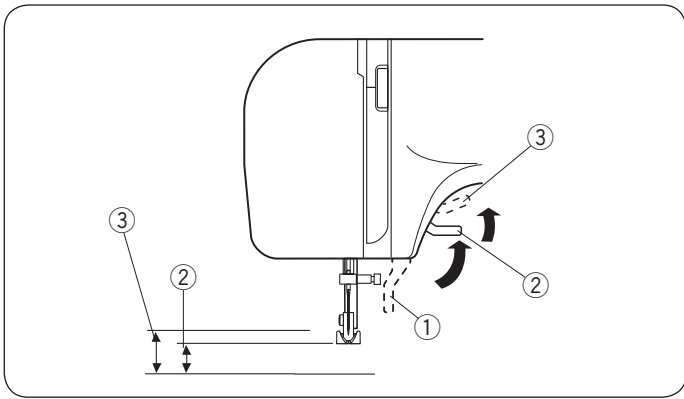

Raising and Lowering the Presser Foot

The presser foot lifter raises and lowers the presser foot.

You can raise the foot about 1/4" (0.6 cm) higher than the normal up position for easy removal of the presser foot, or to help you place heavy fabric under the foot.

- ① Lowered position
- ② Normal up position
- ③ Extra up position

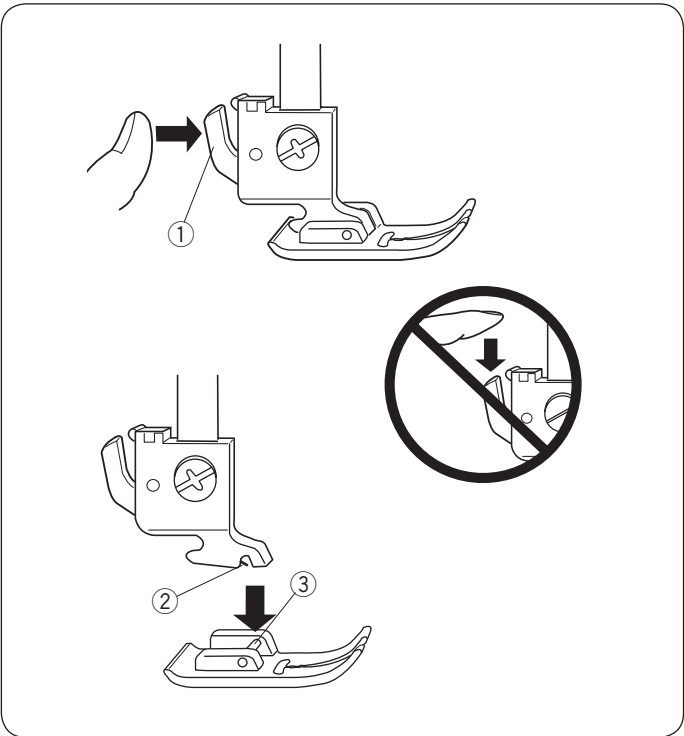

Changing the Presser Foot

To remove:

Raise the needle to its highest position by turning the handwheel counterclockwise. Raise the presser foot, and press the lever on the back of the foot holder.

- ① Lever

⚠ CAUTION:

Turn OFF the power switch before changing the foot. Always use the proper foot for the selected pattern. The wrong foot can cause the needle to break. Do not push the lever down to prevent it from being broken.

To attach:

Place the desired presser foot, so that the pin on the foot lies just under the groove on the foot holder. Lower the presser foot lifter to lock the foot in place.

- ② Groove
- ③ Pin

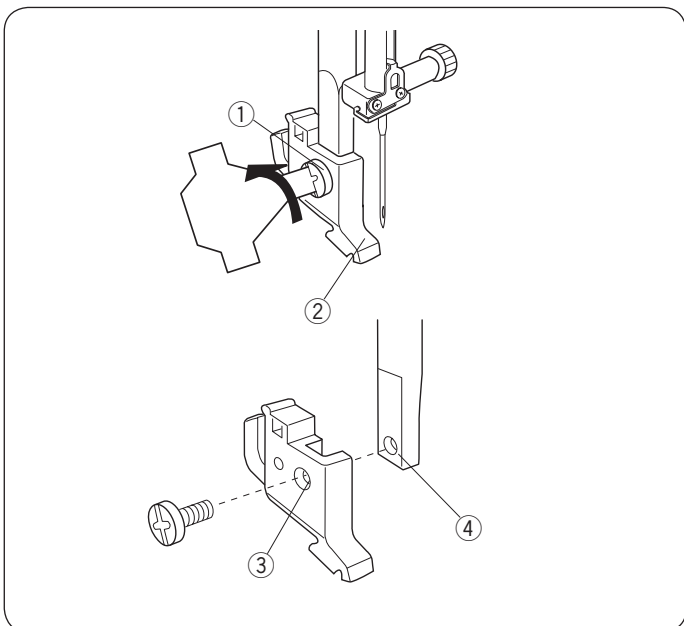

Removing and Attaching the Foot Holder

⚠ WARNING:

Turn OFF the power switch before detaching or attaching the foot holder.

To remove:

Remove the setscrew by turning it counterclockwise with a screwdriver and remove the foot holder.

To attach:

Match the hole in the foot holder with the threaded hole in the presser bar. Fit the setscrew into the hole. Tighten the screw by turning it clockwise with a screwdriver.

- ① Setscrew
- ② Foot holder
- ③ Hole
- ④ Threaded hole

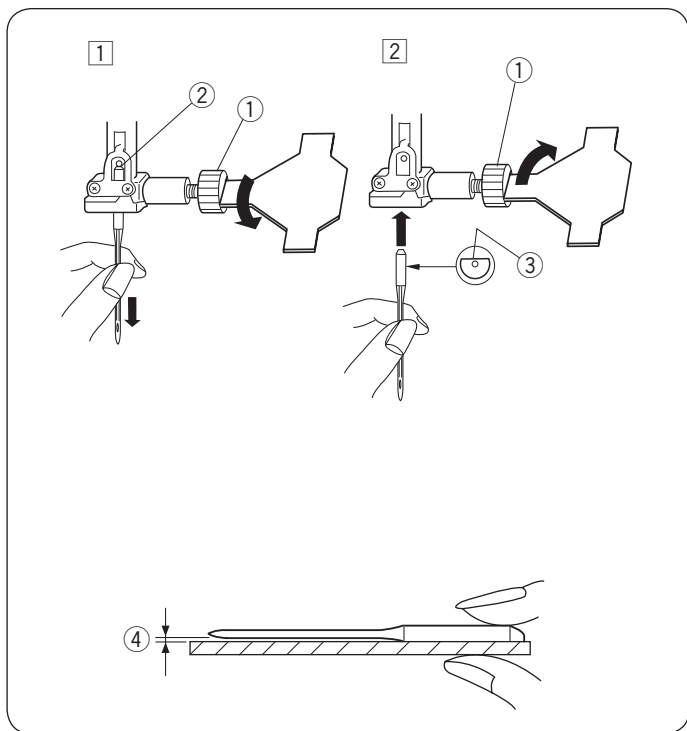

Changing Needles

⚠ CAUTION:

Always make sure to turn the power switch off and disconnect the machine from power supply before changing the needle.

Raise the needle by turning the handwheel and lower the presser foot.

Turn off the power switch.

1 Loosen the needle clamp screw by turning it counterclockwise.

Remove the needle from the clamp.

① Needle clamp screw

2 Insert a new needle into the needle clamp with the flat side of the needle to the rear.

When inserting the needle into the needle clamp, push it up against the stopper pin and tighten the needle clamp screw firmly.

② Stopper pin

③ Flat side

To check needle straightness, place the flat side of the needle onto something flat (glass, etc.)

The gap between the needle and the flat surface should be consistent.

Never use a blunt needle.

④ Gap

Fabric and Needle Chart

- For general sewing, use needle size 11/75 or 14/90.
- A fine thread and needle should be used for sewing lightweight fabrics, so the fabric will not be marred.
- Heavy fabrics require a needle large enough to pierce the fabric without fraying the needle thread.
- Always test the thread and needle size on a small scrap of the fabric that will be used for actual sewing.
- In general, use the same thread for the needle and bobbin.

NOTE:

When sewing stretch fabrics, very fine fabrics and synthetics, use a blue tip needle (Part No. 990311000, sold separately). The blue tip needle effectively prevents skipped stitches.

| Fabric | | Thread | Needle |
|--------------|------------|---|---------------|
| Fine | Lawn | Silk #80-100 Cotton #80-100 Synthetic #80-100 | #9/65-11/75 |
| | Georgette | | |
| | Tricot | | |
| | Organza | | |
| | Crepe | | |
| Medium | Sheeting | Silk #50 Cotton #50-80 Synthetic #50-80 | #11/75-14/90 |
| | Jersey | | |
| | Broadcloth | | |
| | Fleece | | |
| Heavy weight | Denim | Silk #30-50 Cotton #40-50 Synthetic #40-50 | #14/90-16/100 |
| | Tweed | | |
| | Coating | | |
| | Quilting | | |

NOTE:

3 x #14/90 needles are included in the envelop.

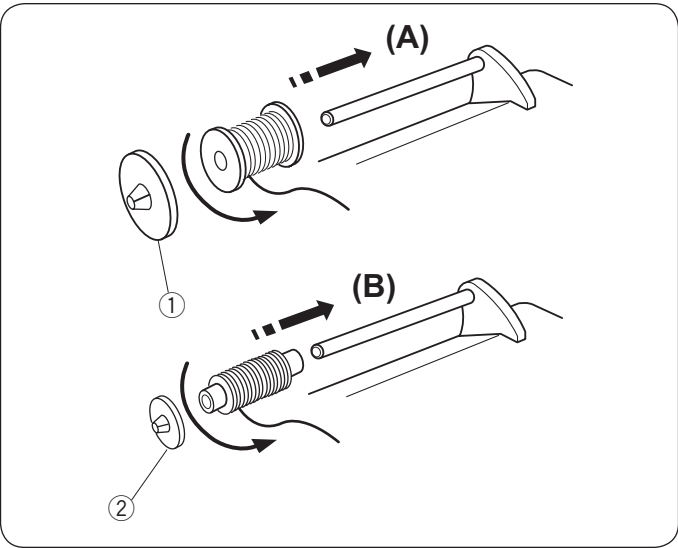

Winding the Bobbin

Setting the spool

Place a spool of thread on the spool pin with the thread coming off the spool as illustrated.

A: Press the large spool holder firmly against the spool of thread.

① Large spool holder

B: For a small spool, use the small spool holder.

② Small spool holder

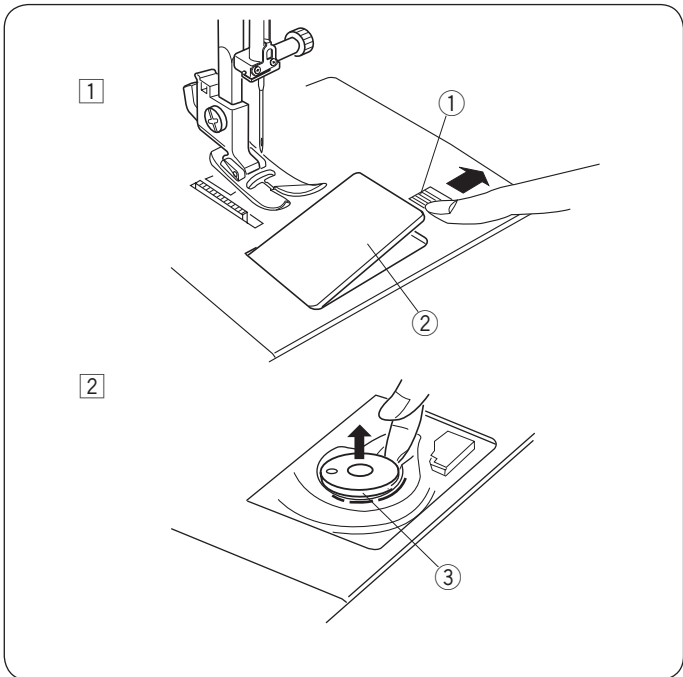

Removing the Bobbin

1 Push the hook cover plate release button to the right and remove the cover plate.

① Hook cover plate release button

② Hook cover plate

2 Lift out the bobbin.

③ Bobbin

Winding the Bobbin

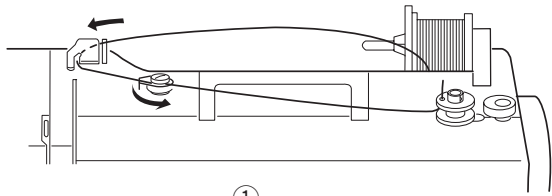

1

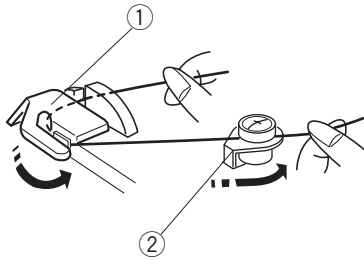

2

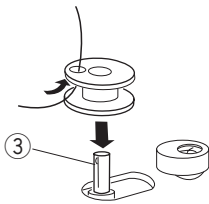

3

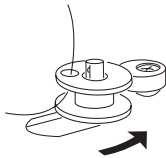

4

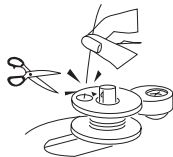

5

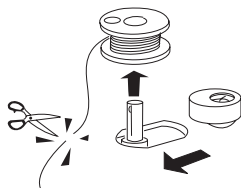

- 1 Hold the thread with both hands and pass the thread under the thread guide. Guide the thread around the bobbin winding thread guide.

- 1 Thread guide
- 2 Bobbin winding thread guide

- 2 Pass the thread through the hole in the bobbin from the inside to the outside.

Put the bobbin on the bobbin winder spindle.

- 3 Bobbin winder spindle

- 3 Push the bobbin winder spindle to the right.

- 4 Hold the free end of the thread in your hand and start the machine.

Stop the machine when the bobbin has been wound a few layers, and cut the thread close to the bobbin.

- 5 Start the machine again. When the bobbin is fully wound, it will stop automatically.

Stop the machine and return the bobbin winder spindle to its original position by moving it to the left, and cut the thread with a pair of scissors. Remove the bobbin from the bobbin winder spindle.

NOTE:

The machine will not sew until the spindle has been returned to the left.

Inserting the Bobbin

- 1 Place the bobbin in the bobbin holder with the thread running off as illustrated.

① Thread

- 2 Guide the thread into the front notch on the front side of the bobbin holder. Draw the thread to the left, sliding it between the tension spring blades.

② Front notch

③ Tension spring blade

- 3 Continue to draw the thread lightly until the thread slips into the side notch.

④ Side notch

- 4 Pull out about 4" (10 cm) of thread. Attach the hook cover plate. Check the threading by referring to the chart shown on the hook cover plate.

⑤ Thread

⑥ Hook cover plate

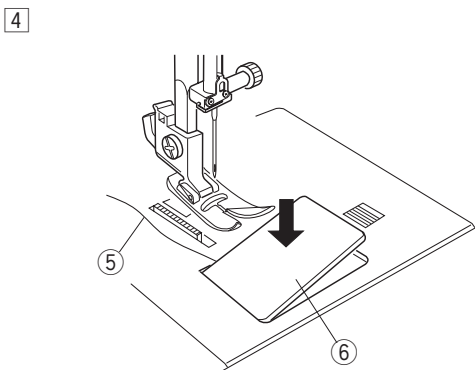
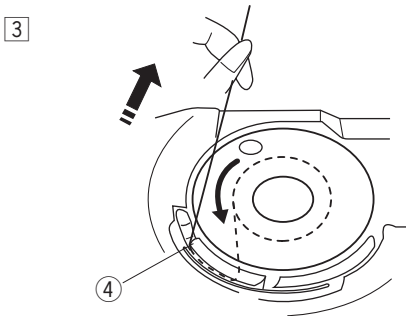
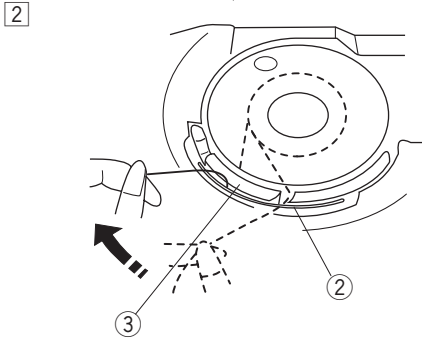
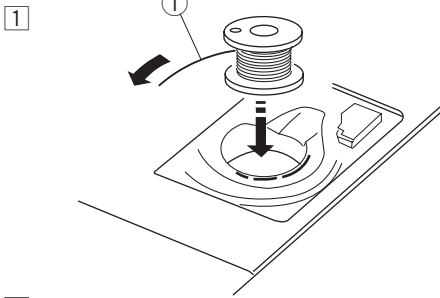

Threading the Machine

To set the needle thread:

Raise the presser foot.

Turn the hand wheel to raise the thread take-up lever to its highest position.

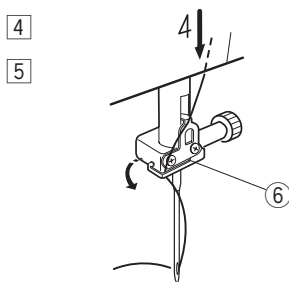
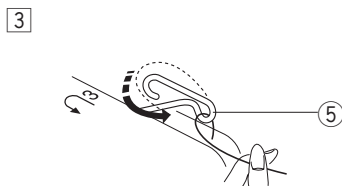
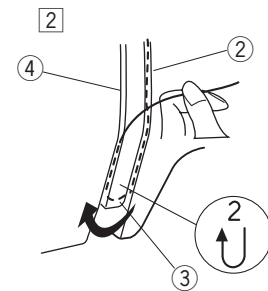
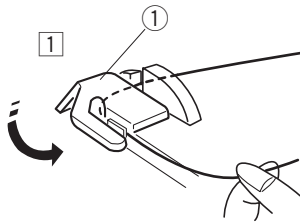
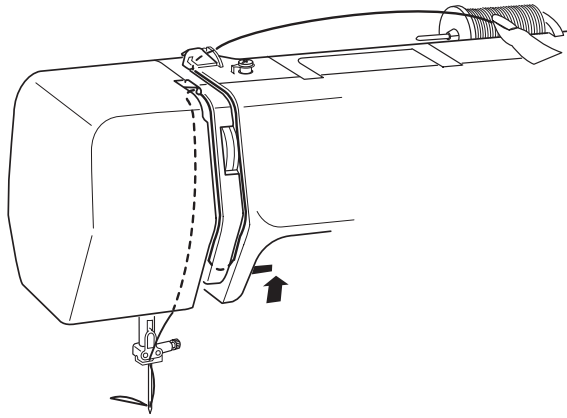

- 1 Draw the thread from the spool and pass it under the thread guide.

① Thread guide

- 2 Draw the thread down along the right channel and pull it up around the bottom of the thread guide plate. Pull the thread up along the left channel.

② Right channel

③ Thread guide plate

④ Left channel

- 3 Firmly draw the thread from right to left over the thread take-up lever and down into the take-up lever eye.

⑤ Thread take-up lever

- 4 Draw the thread down along the left channel and slip the thread behind the needle bar thread guide from the left.

⑥ Needle bar thread guide

- 5 Pass the thread through the needle eye from the front.

Needle Threader

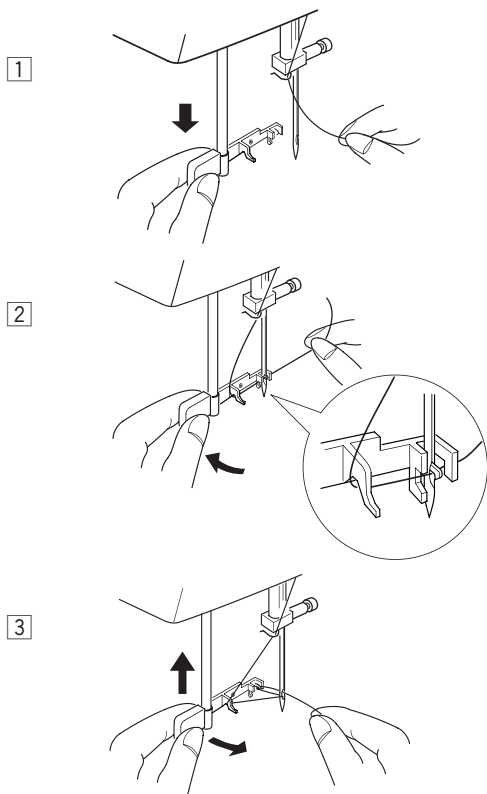

1 Raise the needle to its highest position.
Pull down the needle threader knob as far as it will go.

2 Turn the knob in the direction of the arrow in the illustration, then insert hook into the needle eye.
Lead the thread around guide and under hook.

3 Turn the knob in the direction of the arrow in the illustration, drawing the thread loop through the needle.
Pull the thread through the needle eye.

* The needle threader can be used with a #11 to #16 needle or a Janome Blue tipped needle. Thread size 50 to 90 should also work well.

Drawing up the Bobbin Thread

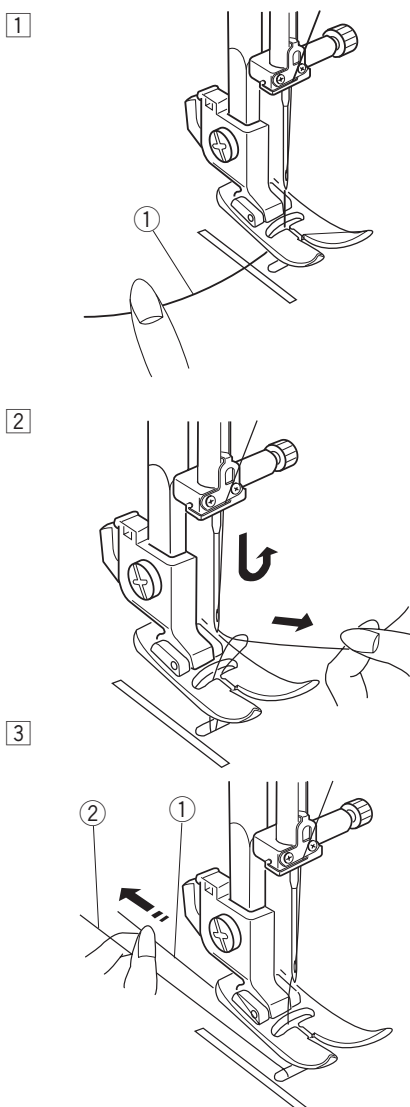

1 Raise the presser foot and hold the needle thread lightly with your left hand.
① Needle thread

2 Turn the handwheel slowly toward you one complete turn. Bring the bobbin thread up by pulling the needle thread as illustrated.

3 Pull 4" (10 cm) of both threads back and under the presser foot.
① Needle thread
② Bobbin thread

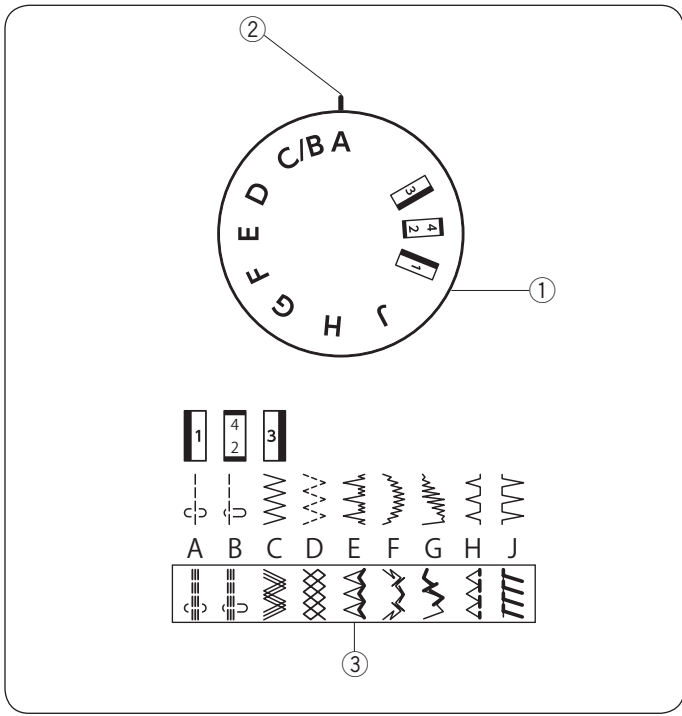

Selecting the Stitch Pattern

Raise the needle to its highest position.

Pattern selector dial

Turn the pattern selector dial to set the symbol of the desired stitch pattern at the setting mark.

- ① Pattern selector dial
- ② Setting mark

⚠ CAUTION:

Do not turn the pattern selector dial while the needle is in the fabric, otherwise the needle may bend or break.

To select the stretch stitch patterns, set the stitch length dial at S.S.

- ③ Stretch stitch patterns

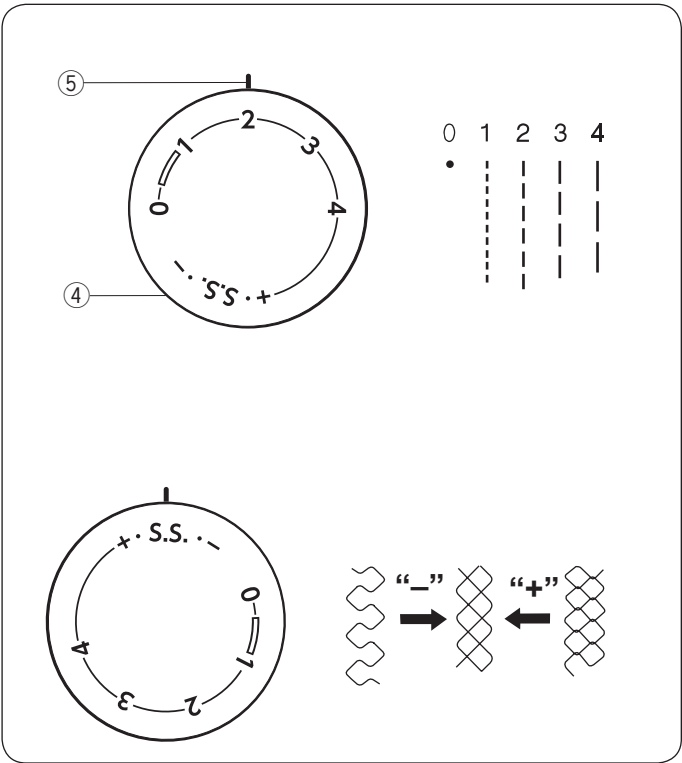

Stitch Length Dial

Turn the stitch length dial to set the desired stitch length number at the setting mark.

The higher the number, the longer the stitch.

The “” mark shows the adjustment range when sewing the buttonhole.

- ④ Stitch length dial
- ⑤ Setting mark

Adjusting stretch stitch balance

If the stretch stitch patterns are uneven when you sew on a particular fabric, correct them by turning the stitch length dial.

If the patterns are drawn out, correct them by setting the dial to the “-” side.

If the patterns are compressed, correct them by setting the dial to the “+” side.

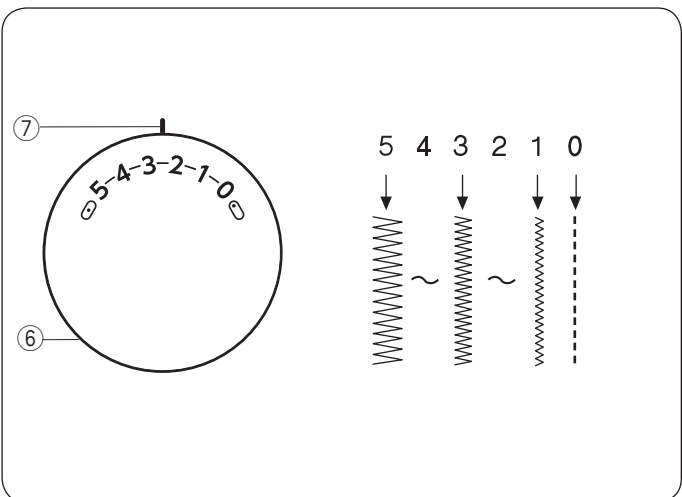

Stitch Width Dial

Turn the stitch width dial to set the desired stitch width at the setting mark .

The higher the number, the wider the stitch width.

- ⑥ Pattern selector dial
- ⑦ Setting mark

NOTE:

Raise the needle above the fabric, when you turn the stitch width dial.

Balancing Needle Thread Tension

The thread tension should be adjusted depending on the sewing materials, layers of fabric and sewing method. To adjust the thread tension, turn the tension dial.

- ① Thread tension dial

Balanced tension:

The ideal straight stitch has threads locked between two layers of fabric, as illustrated.

For an ideal zigzag stitch, the bobbin thread does not show on the right side (top side) of the fabric, and the needle thread shows slightly on the wrong side (bottom side) of the fabric.

- ② Needle thread (Top thread)
- ③ Bobbin thread (Bottom thread)
- ④ Right side (Top side) of fabric
- ⑤ Wrong side (Bottom side) of fabric

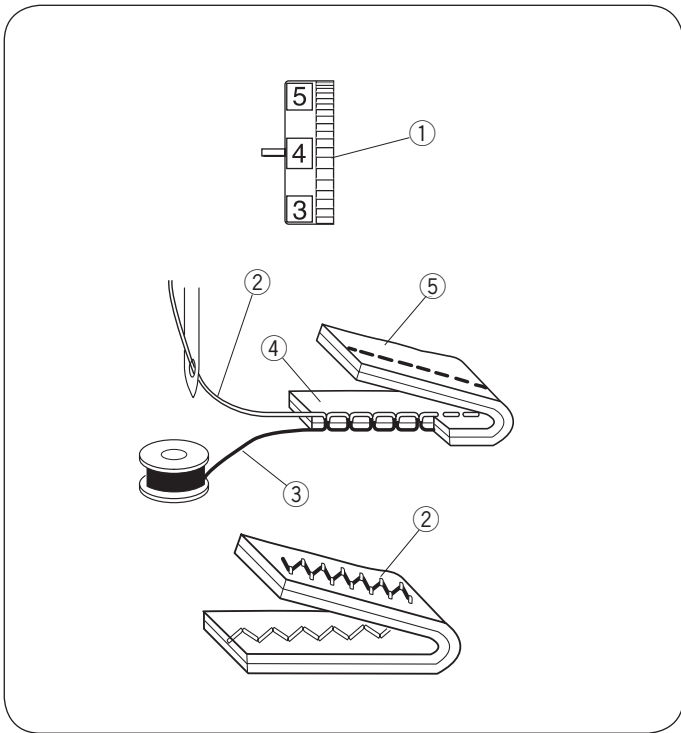

Needle thread tension is too tight:

The bobbin thread (bottom thread) will appear on the right side (top side) of the fabric.

Loosen the needle thread tension by moving the dial to a lower number.

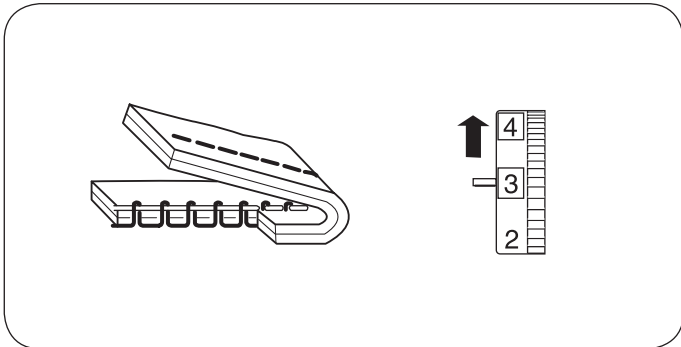

Needle thread tension is too loose:

The needle thread (top thread) will form loops on the wrong side (bottom side) of the fabric.

Tighten the needle thread tension by moving the dial to a higher number.

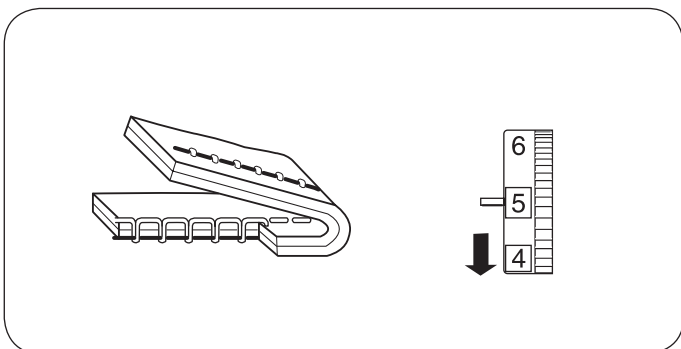

SECTION 3. BASIC SEWING

Straight Stitch Sewing

Machine setting

- | | |
|-------------------|---------------|
| ① Stitch pattern: | A or B |
| ② Presser foot: | Zigzag foot A |
| ③ Thread tension: | 2 - 6 |
| ④ Stitch length: | 1.5 - 4 |
| ⑤ Stitch width: | 0 or 5 |

Starting to sew

Raise the presser foot and place the fabric under the foot. Lower the needle into the fabric. Lower the presser foot and smooth the threads toward the back. Depress the foot control.

NOTE:

Draw the threads to the left when sewing with the buttonhole foot.

To fasten the beginning of the seam, first sew several stitches in reverse then sew forward.

Changing the Sewing Direction

Stop the machine and turn the handwheel toward you to bring the needle down into the fabric. Raise the presser foot. Pivot the fabric around the needle to change sewing direction as desired. Lower the presser foot and continue sewing in the new direction.

Finishing sewing

Press the reverse stitch lever and sew several stitches in reverse at the end of the seam.

Raise the presser foot and remove the fabric, drawing the threads to the back.

Draw the threads up and into the thread cutter. The threads are cut the proper length for starting the next seam.

- ① Thread cutter

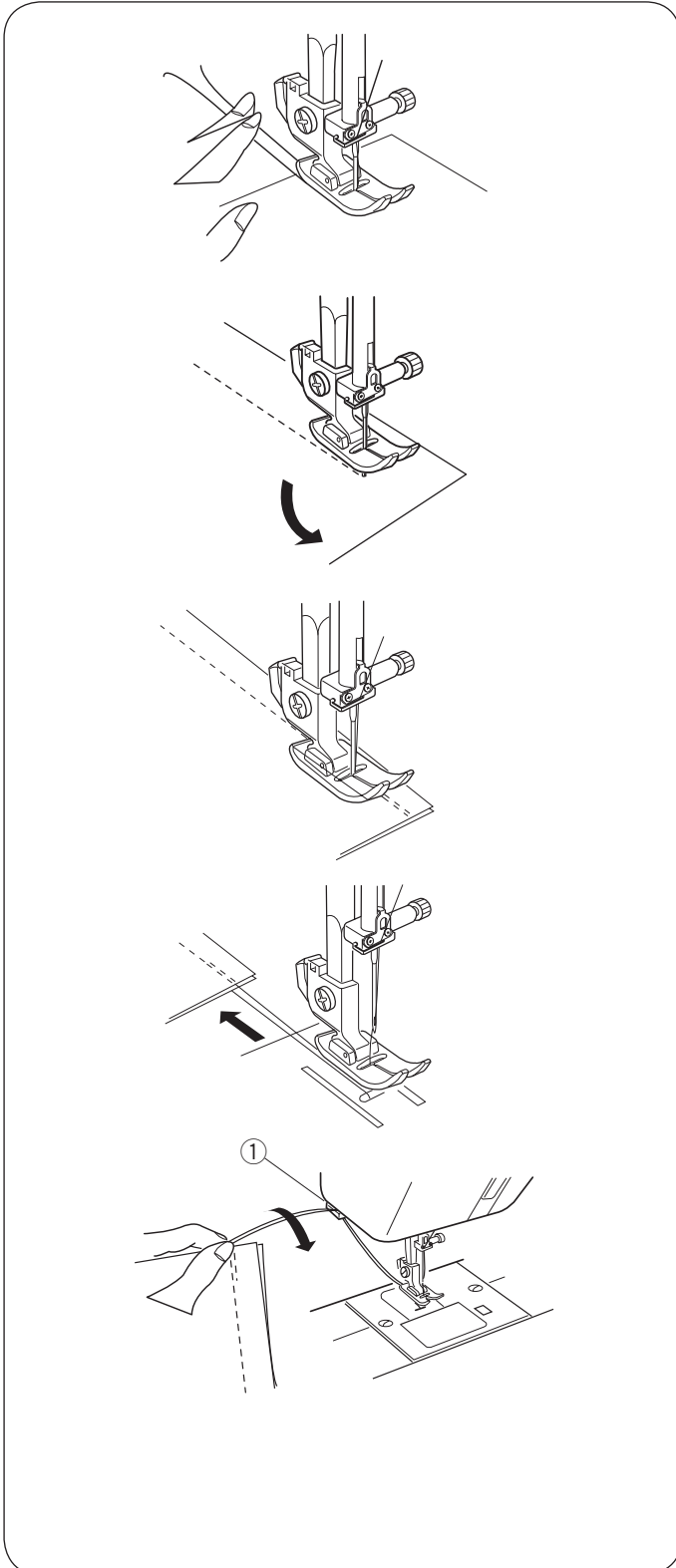
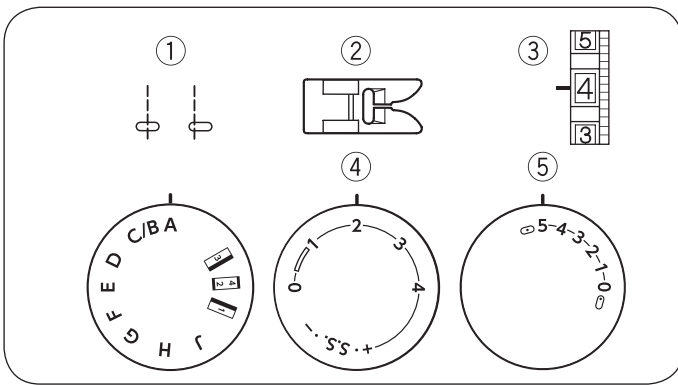

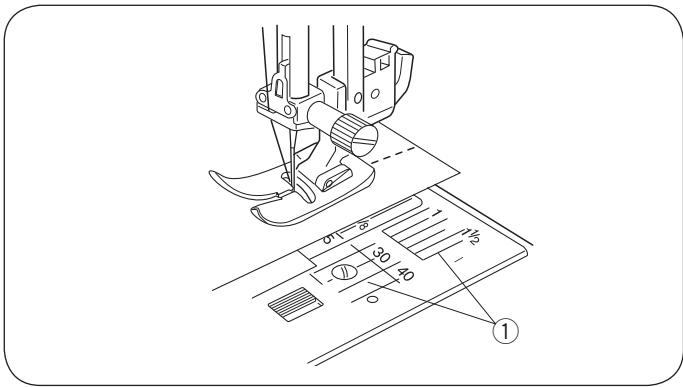

Use the Seam Guide

The seam guides on the needle plate help you to measure seam width.

The numbers indicate the distance between the center needle position and the guide line.

① Seam guides

| | | | | | | | | | |
|-----------------------------|-----|-----|-----|-----|-----|-----|-----|---|-------|
| Numbers on the needle plate | 10 | 15 | 30 | 40 | 3/8 | 1/2 | 5/8 | 1 | 1 1/2 |
| Distance in centimeters | 1.0 | 1.5 | 3.0 | 4.0 | — | — | — | — | — |
| Distance in inches | — | — | — | — | 3/8 | 1/2 | 5/8 | 1 | 1 1/2 |

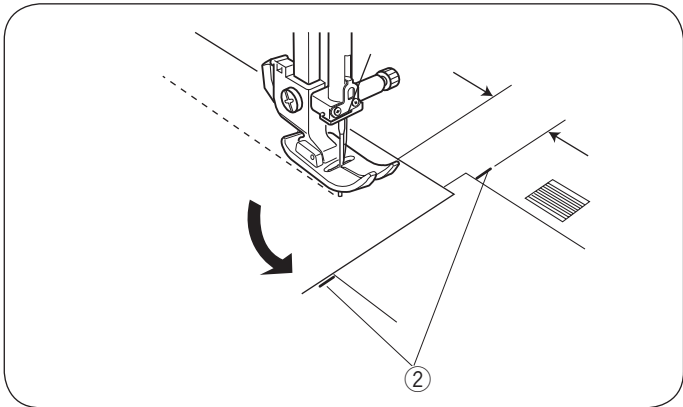

Turning a Square Corner

The cornering guide helps you maintain a 5/8" (1.6 cm) seam allowance when sewing a corner.

When the fabric edge facing you lines up with the cornering guide as illustrated, stop stitching and lower the needle into the fabric by turning the handwheel toward you.

Raise the presser foot and pivot the fabric so the edge of the fabric will align with the 5/8" (1.6 cm) seam guide. Lower the presser foot and start stitching in the new direction.

② Cornering guide

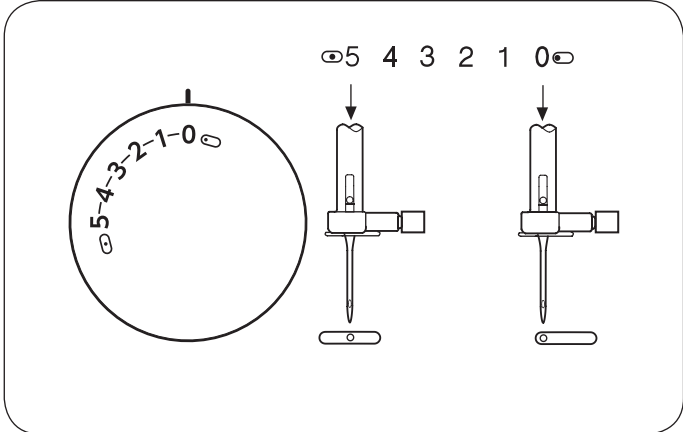

Variable Needle Position

When the straight stitch (pattern A) is selected, you can move the needle between center and left needle position by turning the stitch width dial.

SECTION 4. UTILITY STITCHES

Basic Zigzag

Machine setting

- | | |
|-------------------|---------------|
| ① Stitch pattern: | C |
| ② Presser foot: | Zigzag foot A |
| ③ Thread tension: | 2 - 5 |
| ④ Stitch length: | 0.5 - 3 |
| ⑤ Stitch width: | 1 - 5 |

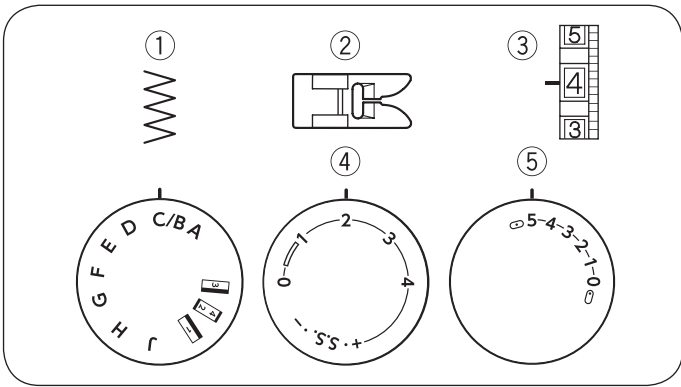

Simple zigzag stitching is widely used for overcasting, sewing on buttons etc.

Adjust the stitch length to suit your sewing needs.

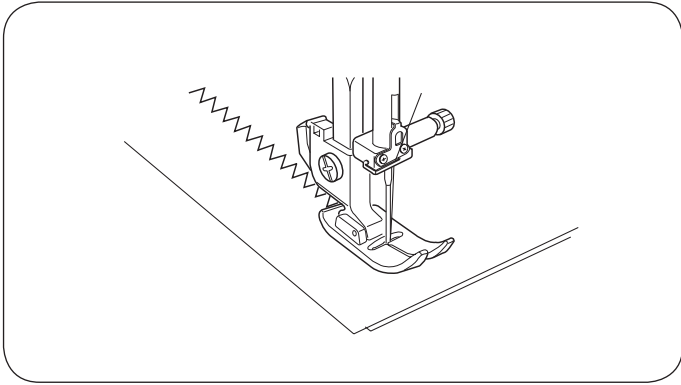

Overcasting

Machine setting

- | | |
|-------------------|---------------|
| ① Stitch pattern: | C |
| ② Presser foot: | Zigzag foot A |
| ③ Thread tension: | 1 - 4 |
| ④ Stitch length: | 1 - 2 |
| ⑤ Stitch width: | 5 |

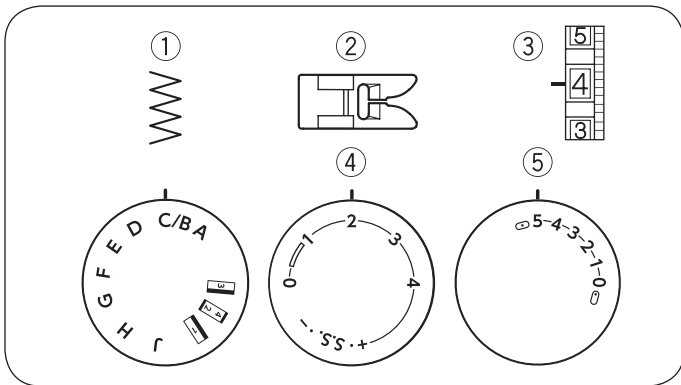

The zigzag stitch is used on the seam allowance to prevent fabric from fraying at raw edges.

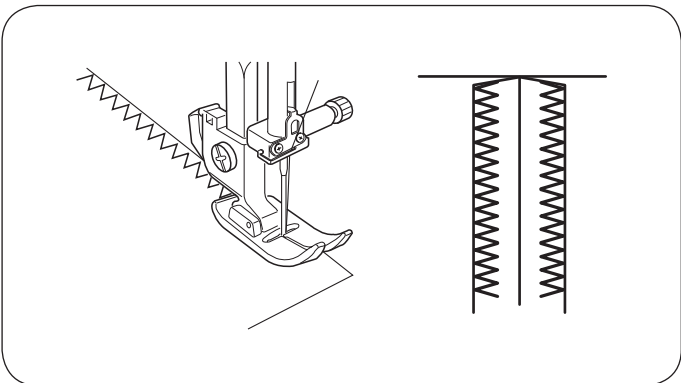

Tricot Stitch (Multiple Zigzag Stitch)

Machine setting

- ① Stitch pattern: D
- ② Presser foot: Zigzag foot A
- ③ Thread tension: 1 - 4
- ④ Stitch length: 0.5 - 1.5
- ⑤ Stitch width: 5

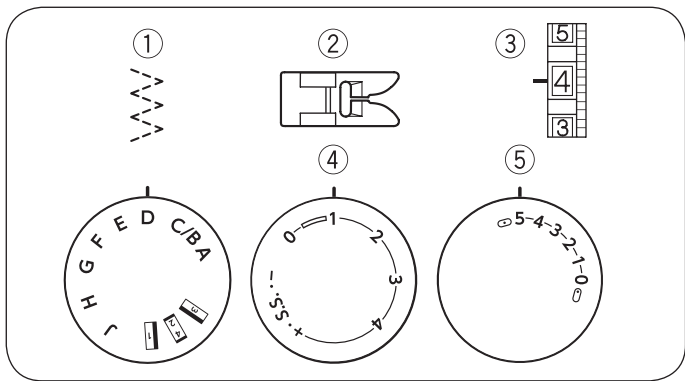

This stitch is used to finish the seam allowance on synthetics and other fabrics that tend to pucker. Place your fabric to allow a 1.6 cm (5/8") seam. Trim the seam allowance after sewing.

It is also handy for darning and mending tears.

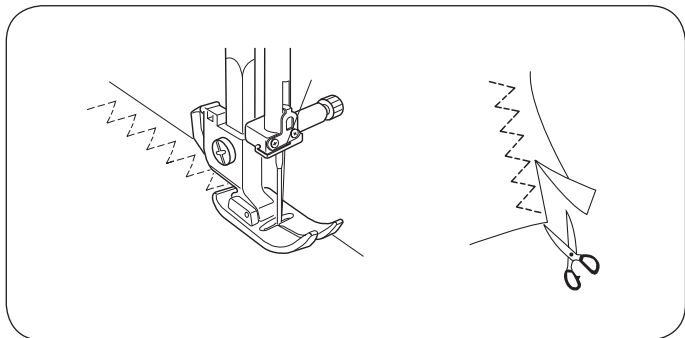

Knit Stitch

Machine setting

- ① Stitch pattern: J
- ② Presser foot: Zigzag foot A
- ③ Thread tension: 1 - 4
- ④ Stitch length: S.S.
- ⑤ Stitch width: 5

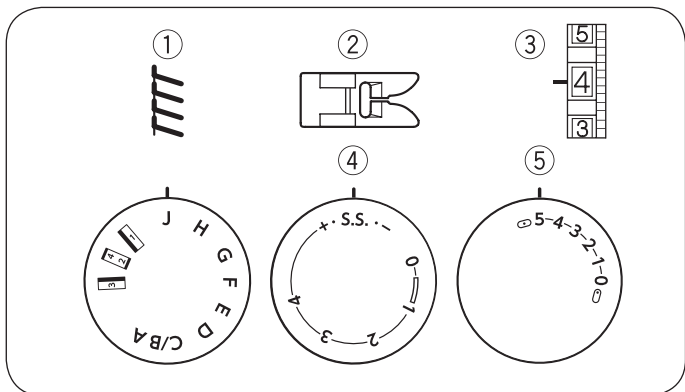

This stitch is ideal for 1/4" (0.6 cm) seams on knits or on medium to heavy weight woven fabrics where you want a narrow seam. It is also great for sewing spandex swim wear. Place the fabric to leave a 5/8" (1.6 cm) allowance. Trim the extra allowance after sewing.

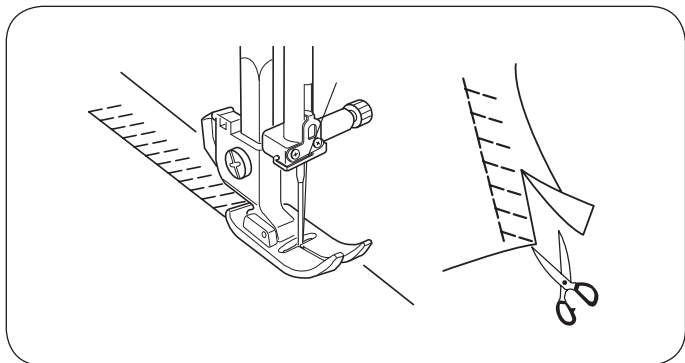

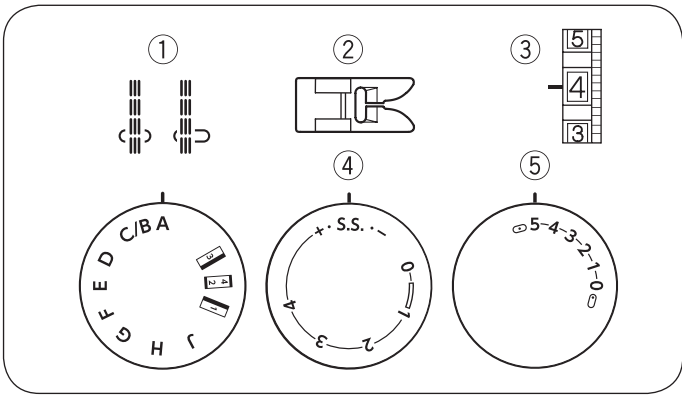

Straight Stretch Stitch

Machine setting

- ① Stitch pattern: A or B
- ② Presser foot: Zigzag foot A
- ③ Thread tension: 2 - 6
- ④ Stitch length: S.S.
- ⑤ Stitch width: 5 or 0

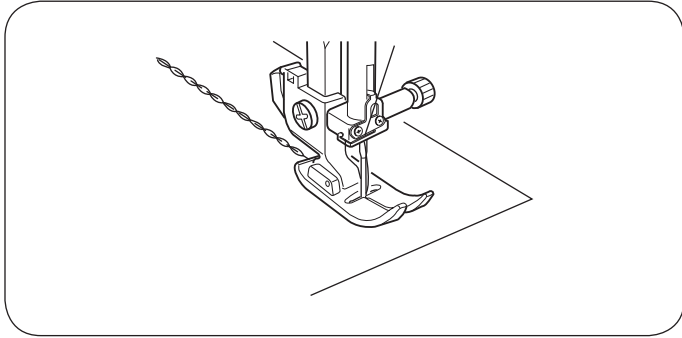

The pattern is sewn with two stitches forward and one stitch backward, forming a seam that does not rip easily. Use it to reinforce areas such as crotch and armhole seams.

Also use it when constructing items such as backpacks for extra strength.

Carefully guide the fabric while sewing as the fabric moves back and forth.

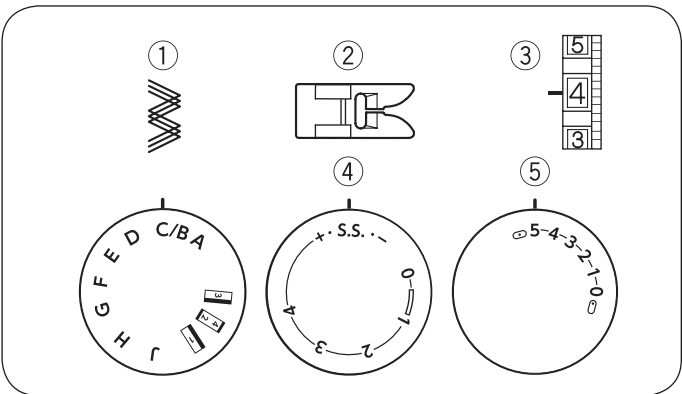

Zigzag Stretch Stitch

Machine setting

- ① Stitch pattern: C
- ② Presser foot: Zigzag foot A
- ③ Thread tension: 2 - 6
- ④ Stitch length: S.S.
- ⑤ Stitch width: 5 or 0

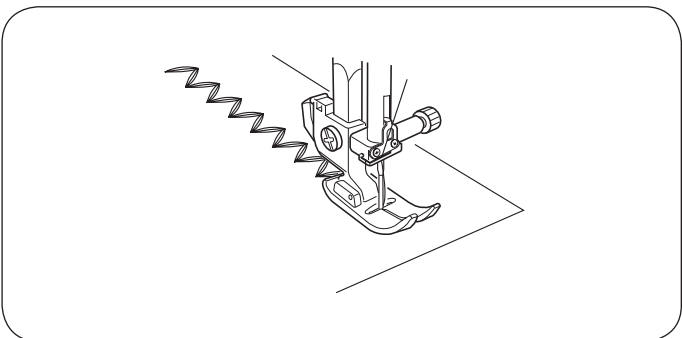

Sew on stretch fabrics in any area that you might use a zigzag stitch.

This stitch is used as a decorative topstitch as well.

Button Sewing

Machine setting

- | | |
|-------------------|---------------------|
| ① Stitch pattern: | C |
| ② Presser foot: | Zigzag foot A |
| ③ Thread tension: | 3 - 7 |
| ④ Stitch length: | Any |
| ⑤ Stitch width: | Adjust as necessary |
| ⑥ Feed dog: | Dropped |

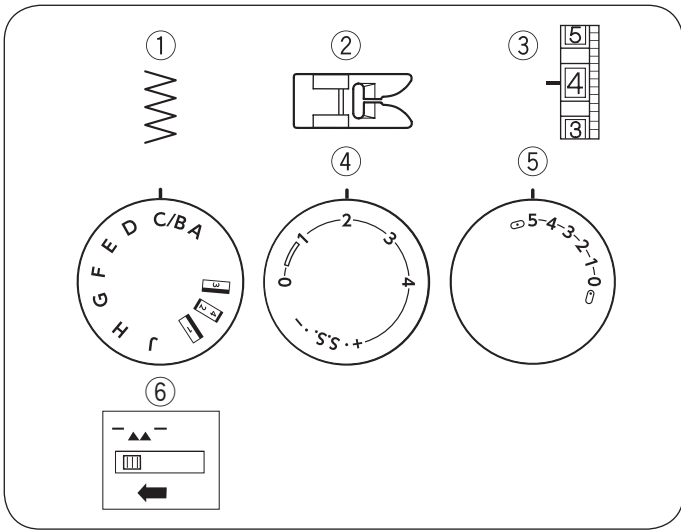

Unthread the needle. Adjust the stitch width to match it with the span of the holes in the button.

Turn the handwheel to check if the needle enters into each hole in the button.

Lower the foot to hold the button in place.

The holes in the button should align with the slot of the foot.

A pin can be placed on the foot to form a shank.

Make sure to check if the needle enters into both holes in the button.

① Pin

Re-thread the needle and sew about 10 stitches and cut the needle and bobbin threads at the beginning.

Raise the presser foot and remove the fabric.

Cut the needle and bobbin threads leaving 8" (20 cm) tails.

Bring the needle thread between the button and fabric through the holes in the button.

Pull the needle thread to pick bobbin thread up to the right side of the fabric.

Wind the threads to form a shank and tie them together.

② Needle thread

③ Bobbin thread

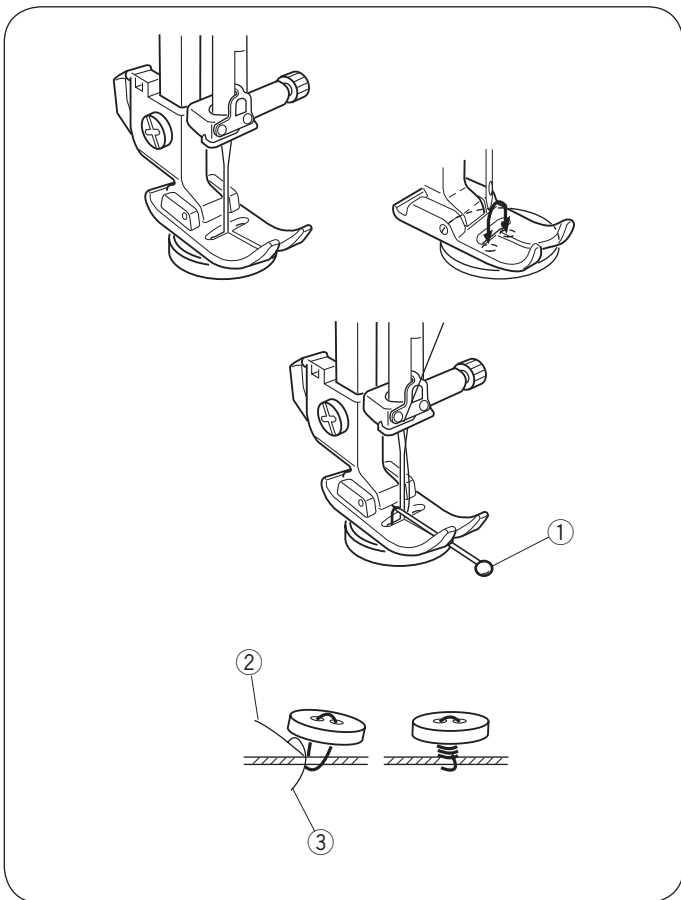

NOTE:

Raise the feed dog after sewing.

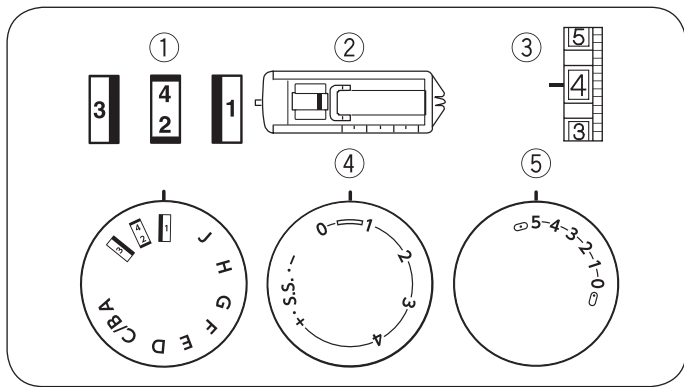

4-Step Buttonhole

Machine setting

- | | |
|-------------------|---------------------------|
| ① Stitch pattern: | |
| ② Presser foot: | Sliding buttonhole foot J |
| ③ Thread tension: | 1 - 5 |
| ④ Stitch length: | 0.5 - 1 |
| ⑤ Stitch width: | 3 - 5 |

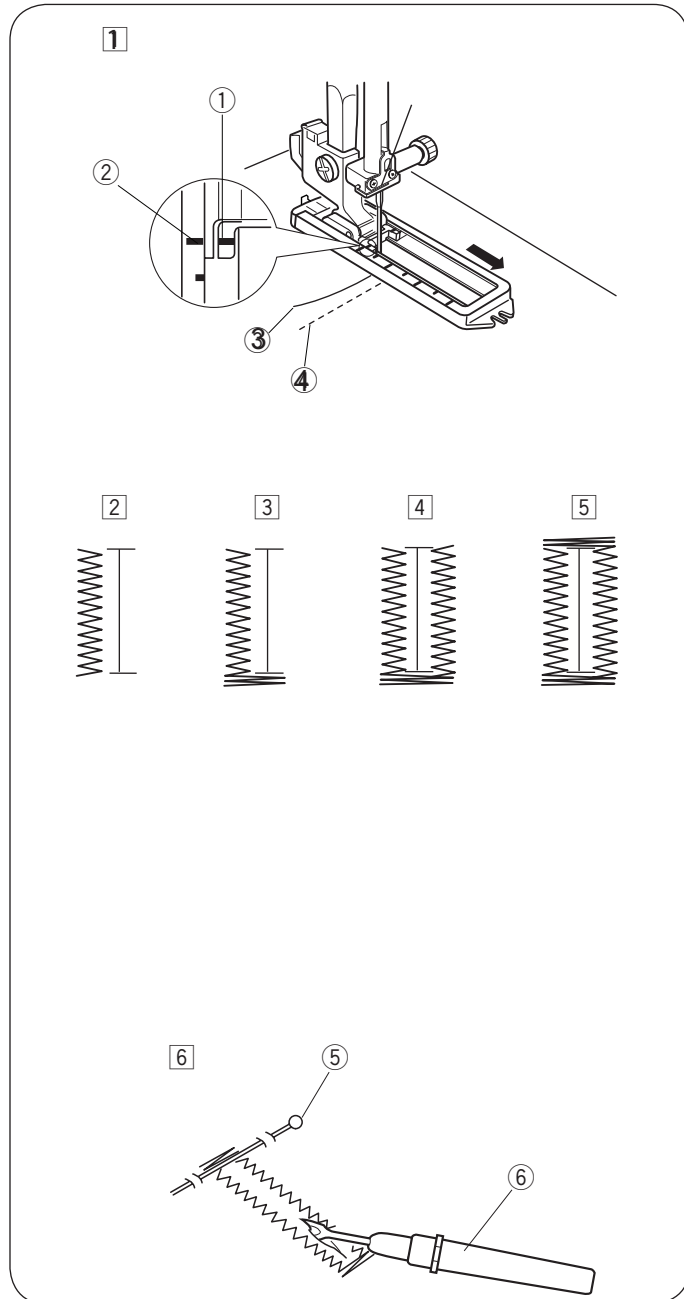

- ① Set the pattern selector dial at “1”. Carefully mark buttonhole length on fabric. Place the fabric under the foot with the buttonhole marking running toward you. Draw both of needle and bobbin thread to the left. Move the slider toward you so that the top mark ② on the slider meets the start mark ①.

- ① Start mark
- ② Top mark
- ③ Needle thread
- ④ Bobbin thread

NOTE:

The scale on the slider is engraved in centimeters.

- ② Sew forward until you reach the front marking of your buttonhole. Stop sewing at a left stitch.
- ③ Raise the needle to its highest position. Set the pattern selector dial at “2”. Sew 5 stitches, then stop sewing at a right stitch.
- ④ Raise the needle to its highest position. Set the pattern selector dial at “3”. Sew until the needle reach the back marking of the buttonhole.
- ⑤ Raise the needle to its highest position. Set the pattern selector dial at “2”. Sew 5 stitches, then stop sewing. Set the stitch length dial to “0” and the pattern selector dial at straight sewing. Sew a few locking stitches.
- ⑥ Raise the needle and presser foot. Remove the fabric from the machine and cut the sewing thread. Insert a pin inside the bartack. Then cut the opening with a seam ripper. Take care not to cut the stitches.

- ⑤ Pin
- ⑥ Seam ripper

To adjust buttonhole stitch density

Set the stitch length dial between “0” to adjust the buttonhole stitch density.

- ⑦ Denser buttonhole
- ⑧ Coarser buttonhole

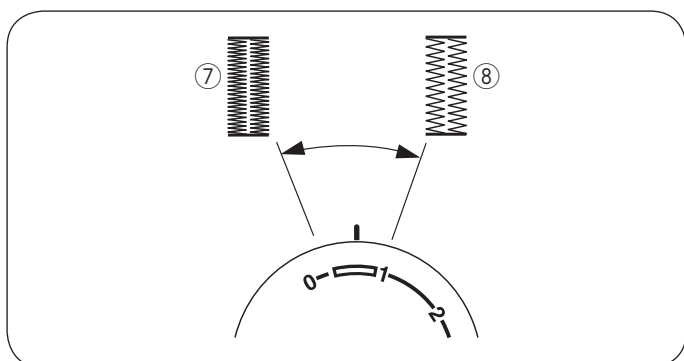

Corded Buttonhole

Machine setting

- | | |
|-------------------|---------------------------|
| ① Stitch pattern: | |
| ② Presser foot: | Sliding buttonhole foot J |
| ③ Thread tension: | 1 - 5 |
| ④ Stitch length: | 0.5 - 1 |
| ⑤ Stitch width: | 3 - 5 |

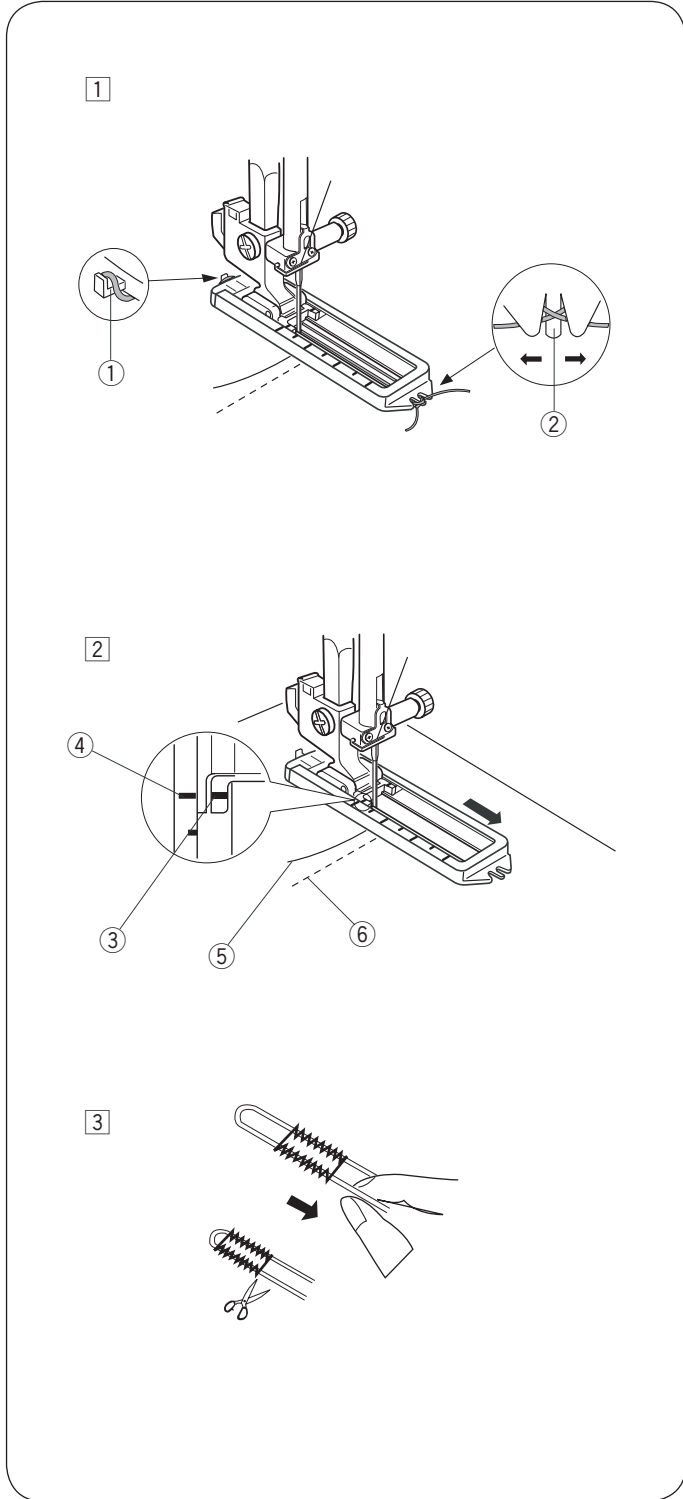
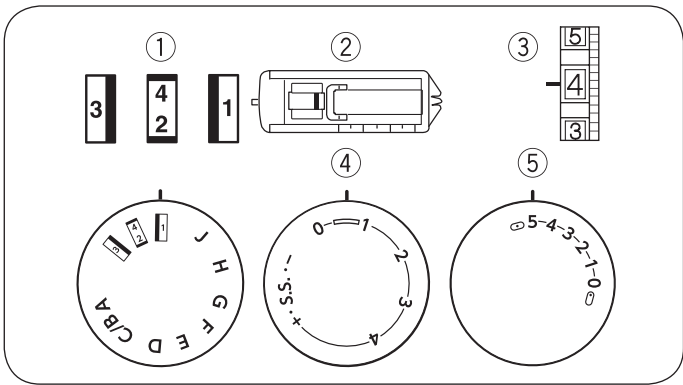

- 1 With the buttonhole foot raised, hook the filler cord on the spur at the back of the foot. Bring the ends toward you under the foot, clearing the front end. Hook the filler cord into the forks on the front of the foot to hold them tight.

- ① Spur
- ② Forks

- 2 Draw both of needle and bobbin thread to the left. Move the slider toward you so that the top mark ④ on the slider meets the start mark ③.

- ③ Spur
- ④ Forks
- ⑤ Spur
- ⑥ Forks

Lower the needle into the fabric at the starting point and lower the foot. Depress the foot control gently and sew the buttonhole over the cord. The sewing sequence is the same as the 4-step buttonhole.

- 3 Pull the left end of the filler cord to tighten it and cut the excess tails. To cut the buttonhole opening, refer to the instructions on page 21.

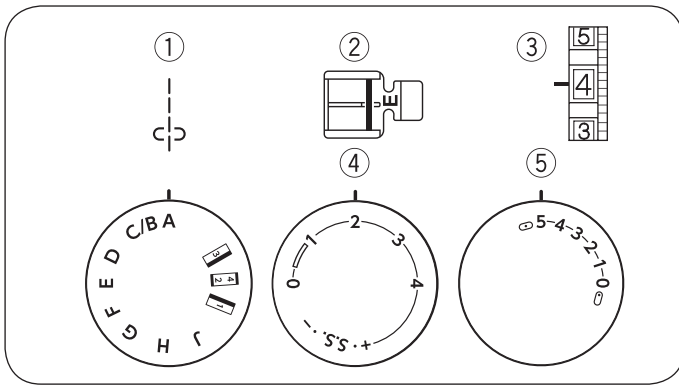

Zipper Application

Machine setting

- | | |
|-------------------|---------------|
| ① Stitch pattern: | A |
| ② Presser foot: | Zipper foot E |
| ③ Thread tension: | 3 - 6 |
| ④ Stitch length: | 1.5 - 4 |
| ⑤ Stitch width: | 5 |

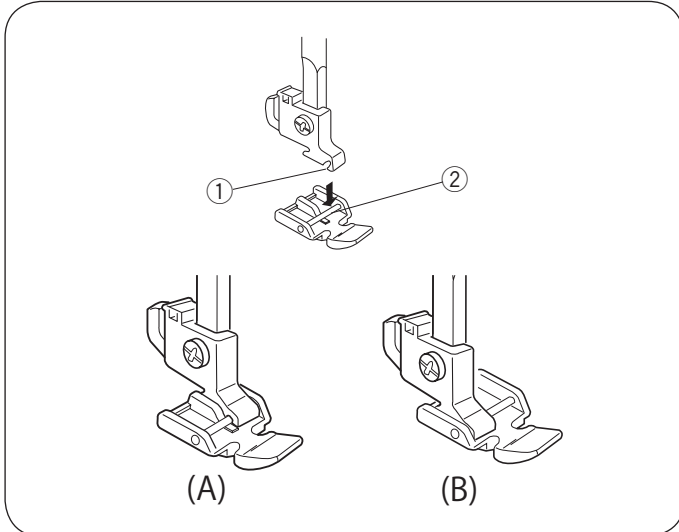

To snap on the zipper foot

A: To sew the left side of the zipper, attach zipper foot with the right side pin.

B: To sew the right side of zipper, attach the zipper foot with the left side pin.

- ① Groove
- ② Pin

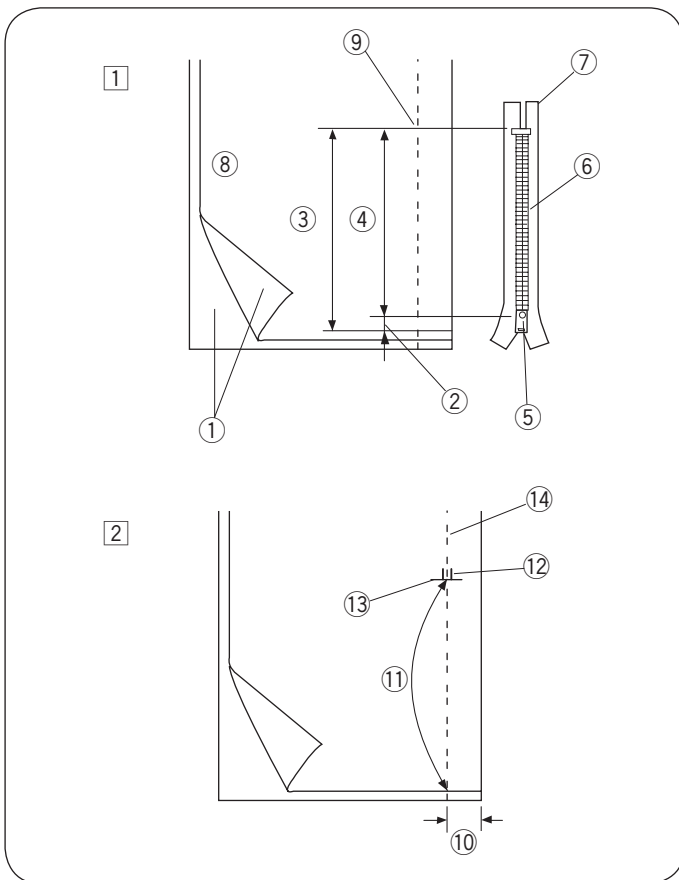

Fabric preparation

① Add 3/8" (1 cm) to the zipper size. This is the overall opening size.

- ① Right side of the fabric
- ② 3/8" (1 cm)
- ③ Opening size
- ④ Zipper size
- ⑤ Slider
- ⑥ Zipper teeth
- ⑦ Zipper tape
- ⑧ Wrong side of the fabric
- ⑨ End of the opening

② Place the right (top) sides of the fabric together. Sew a bottom seam 5/8" (2 cm) from the right edge to the zipper bottom stop position. Sew a few stitches in reverse to lock.

Increase the stitch length to "4", set needle thread tension to "1", and baste the entire length of the fabric.

- ⑩ 5/8" (2 cm)
- ⑪ Basting
- ⑫ Reverse stitch
- ⑬ End of the opening
- ⑭ Bottom seam

To sew

- 1 Attach zipper foot with the right side pin.
Fold back the upper layer seam allowance.
Fold back the lower layer seam allowance to leave a 1/8" (0.4 cm) margin of fabric.

- 1 Lower layer
- 2 End of the opening
- 3 Zipper teeth
- 4 1/8" (0.4 cm) margin
- 5 Upper layer
- 6 Opening size
- 7 Folded edge
- 8 Basting

- 2 Place zipper teeth next to margin edge and baste the zipper tape to the lower fabric layer.
Align zipper foot with margin edge. Return thread tension and stitch length to original settings.
Sew a seam the entire length of zipper tape.

- 3 Stop the machine 2" (5 cm) before reaching the slider, with needle in the fabric and raise the foot, then unzip a few inches to clear a path for stitching.

- 9 Slider
- 10 2" (5 cm)

- 4 Remove fabric and close zipper. Take the upper fabric layer and lay it flat over the zipper.
Baste the zipper tape to the upper fabric layer.

- 11 Basting
- 12 Zipper tape

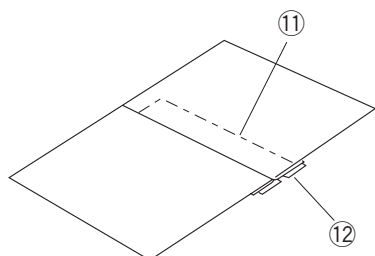
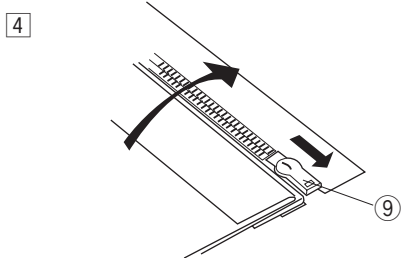
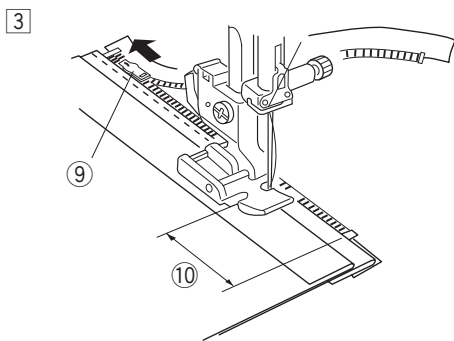
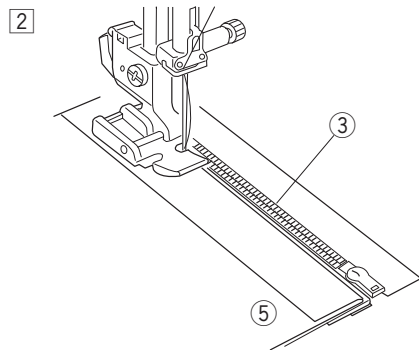
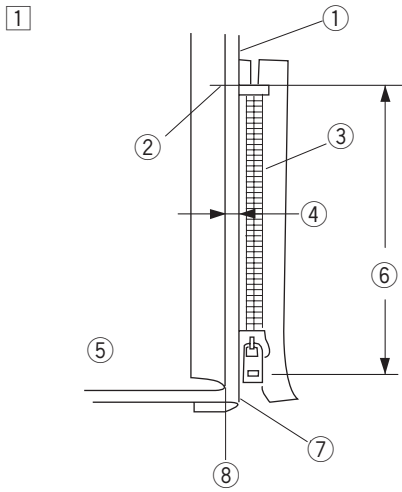

5

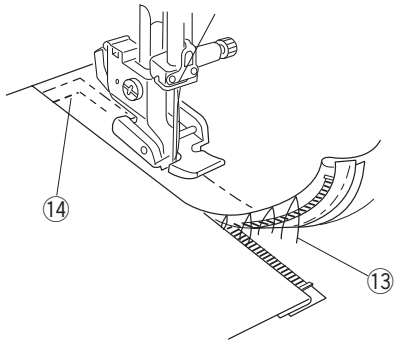

- 5 Raise and release the foot, and re-attach it with the left side pin. Starting just below zipper bottom stop, sew across fabric to about 3/8" (1 cm) distance from the basting line.

Turn fabric 90 degrees and sew a seam the entire length of the zipper tape. Before reaching the slider, stop the machine with needle in fabric and raise the foot. Use seam ripper to open a few inches of basting stitch.

13 Unstitch basting

14 3/8" (1 cm)

6

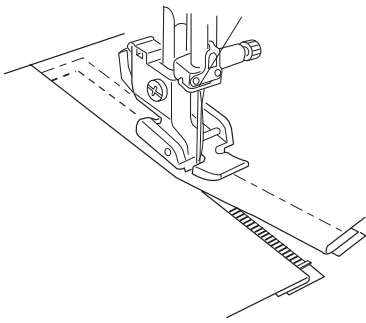

- 6 Unzip a few inches to clear a path for stitching. At end of seam, sew a few stitches in reverse to lock. Once both sides of zipper are sewn, use the seam ripper to open the basting stitch.

Blind Hemming

Machine setting

- | | |
|-------------------|----------------------|
| ① Stitch pattern: | E or H |
| ② Presser foot: | Blind hemming foot G |
| ③ Thread tension: | 2 - 4 |
| ④ Stitch length: | 1 - 3 |
| ⑤ Stitch width: | 5 |

- ① On heavy weight fabrics that ravel, the raw edge should be overcast first.
Fold the hem under the fabric as illustrated for fine or medium fabrics.
Fold a hem with the wrong side up forming a 1/8" (0.5 cm) allowance.

- ① Wrong side of the fabric
② 1/8" (0.5 cm)
③ Heavy weight fabric
④ Fine and medium weight fabric

- ② Place the fabric so that the needle just pierces the folded edge when the needle comes over the extreme left side.
Lower the presser foot.

- ③ Turn the screw to align the guide on the foot with the folded edge so that the needle just pierces the fold.
If the needle pierces too far left, move the guide slightly to the left.
If the needle misses the fold, move the guide slightly to the right.

- Sew slowly while guiding the folded edge along the guide.
⑤ Screw
⑥ Guide
⑦ Folded edge

- ④ Open and press the fabric after sewing is finished.
⑧ Right side of the fabric

NOTE:

If the needle drops too far left, the stitches will be apparent on the right side of the fabric.

SECTION 5. DECORATIVE STITCHES

Shell Tuck

Machine setting

- | | |
|-------------------|---------------|
| ① Stitch pattern: | J |
| ② Presser foot: | Zigzag foot A |
| ③ Thread tension: | 6 - 8 |
| ④ Stitch length: | 2 - 3 |
| ⑤ Stitch width: | 5 |

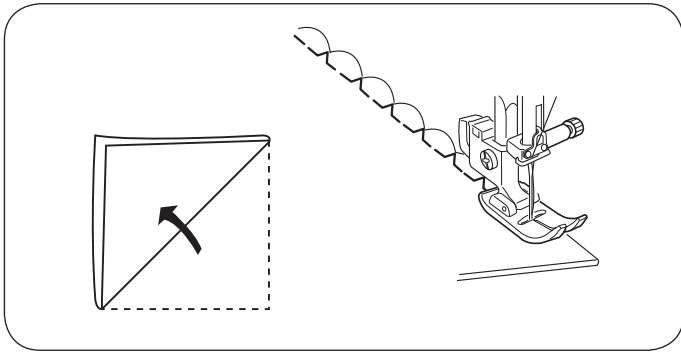
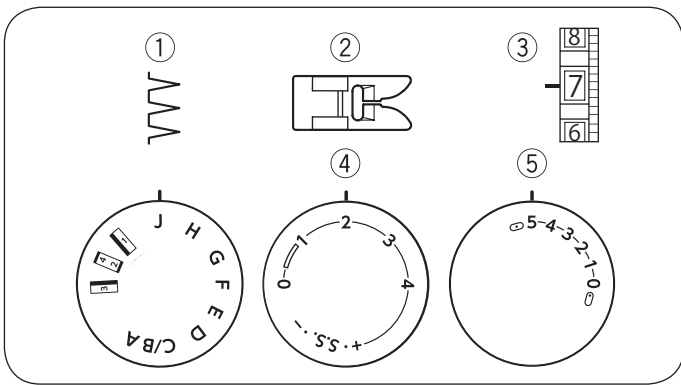

Place the folded edge along the slot of foot. The needle should fall off the edge of the fabric on the right forming a tuck.

Smocking

Machine setting

- | | |
|-------------------|---------------|
| ① Stitch pattern: | A, D |
| ② Presser foot: | Zigzag foot A |
| ③ Thread tension: | 1 - 4 |
| ④ Stitch length: | S.S. |
| ⑤ Stitch width: | 5 |

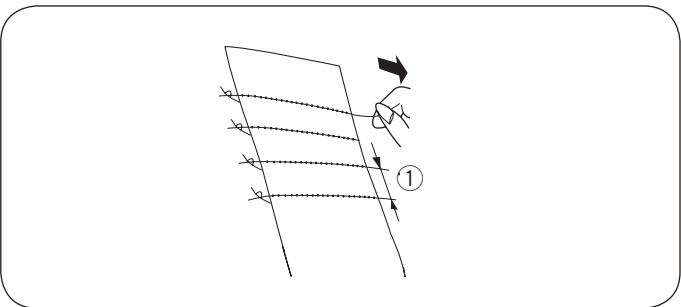
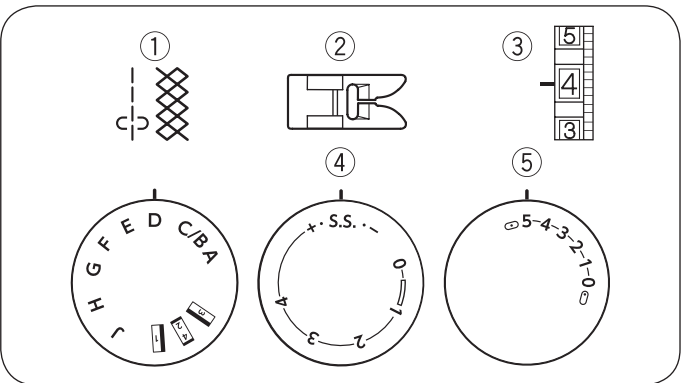

Choose a soft and lightweight fabric such as batiste, gingham or challis. Cut the fabric three times wider than the project width.

Increase the stitch length to "4" and loosen thread tension to "1". Sew rows of straight stitches 3/8" (1 cm) apart across the area to be smocked.

- ① 1 cm (3/8")

Knot the threads along one end. From the other end, pull the bobbin threads to distribute gathers evenly and secure the threads.

Return the thread tension to the original setting.

Sew rows of the smocking stitch between the gathering stitches.

Remove the gathering stitches after finished.

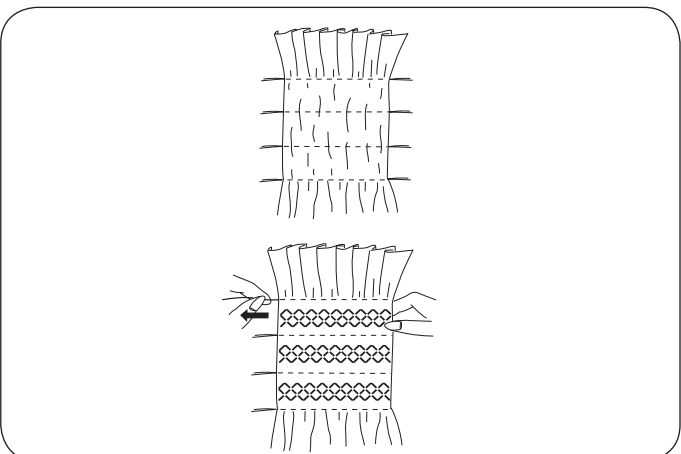

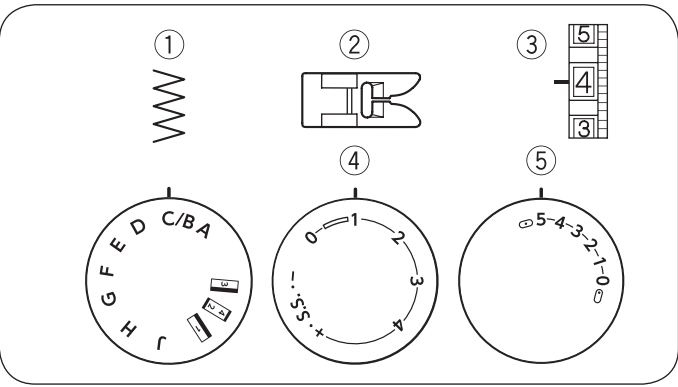

Applique

Machine setting

- | | |
|-------------------|---------------|
| ① Stitch pattern: | C |
| ② Presser foot: | Zigzag foot A |
| ③ Thread tension: | 1 - 4 |
| ④ Stitch length: | 0.5 - 1 |
| ⑤ Stitch width: | 5 |

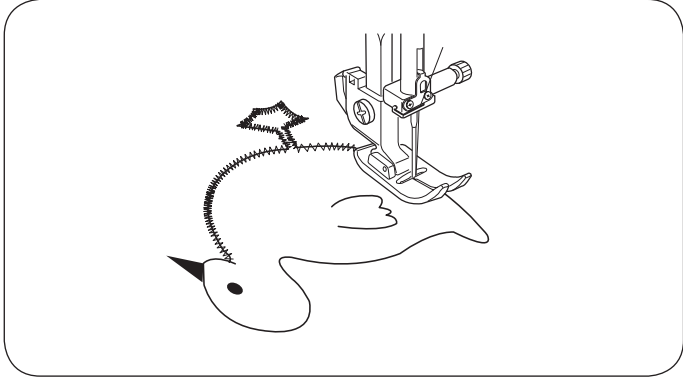

Baste (or fuse with iron-on fabric joiner) applique pieces on the fabric. Stitch around the applique making sure the needle falls along the outer edge of the applique.

When sewing corners, lower the needle down into the fabric. Raise the presser foot and pivot fabric to the right or left.

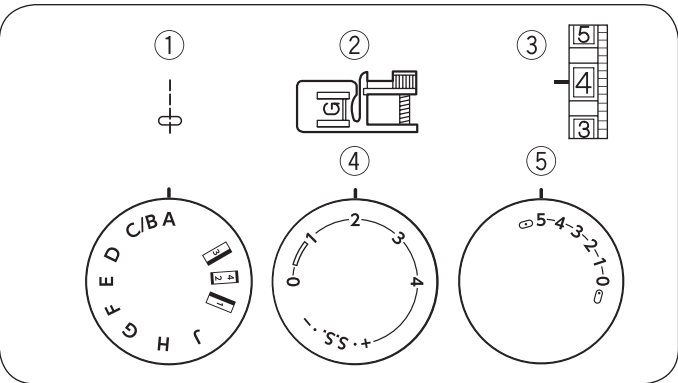

Pin Tucking

Machine setting

- | | |
|-------------------|----------------------|
| ① Stitch pattern: | A |
| ② Presser foot: | Blind hemming foot G |
| ③ Thread tension: | 3 - 6 |
| ④ Stitch length: | 1.5 - 4 |
| ⑤ Stitch width: | 5 |

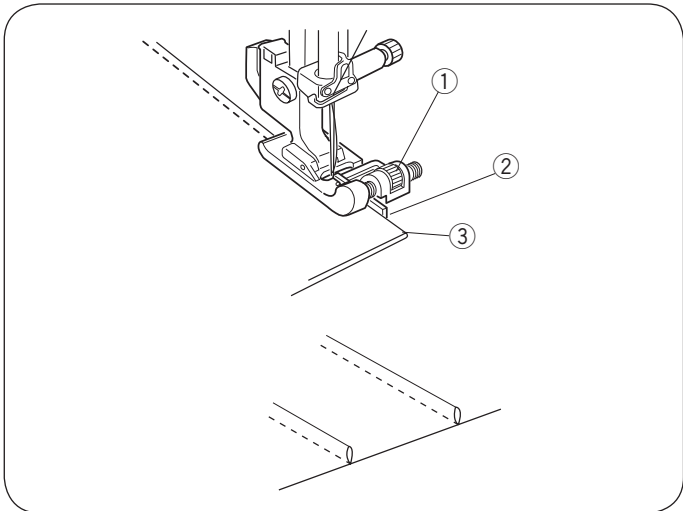

Fold a fabric wrong side together and Lower the needle into the fabric 0.1 – 0.2 cm inside the folded edge.

Lower the foot and turn the screw to align the guide on the foot with the folded edge.

Sew slowly while guiding the folded edge along the guide.

Open the fabric and iron press the tucks.

- ① Screw
- ② Guide
- ③ Folded edge

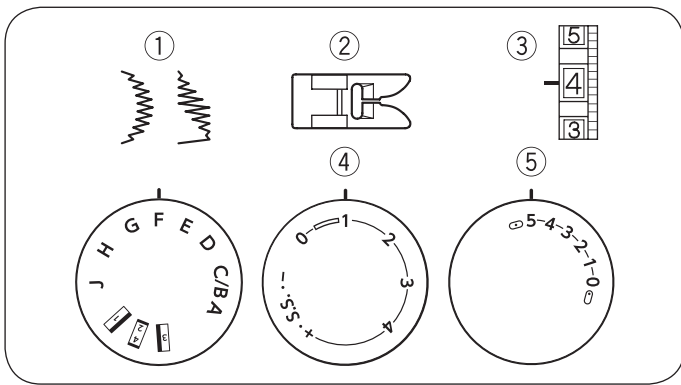

Satin Stitches

Machine setting

- ① Stitch pattern: F or G
- ② Presser foot: Zigzag foot A
- ③ Thread tension: 1 - 4
- ④ Stitch length: 0.5 - 1
- ⑤ Stitch width: 3 - 5

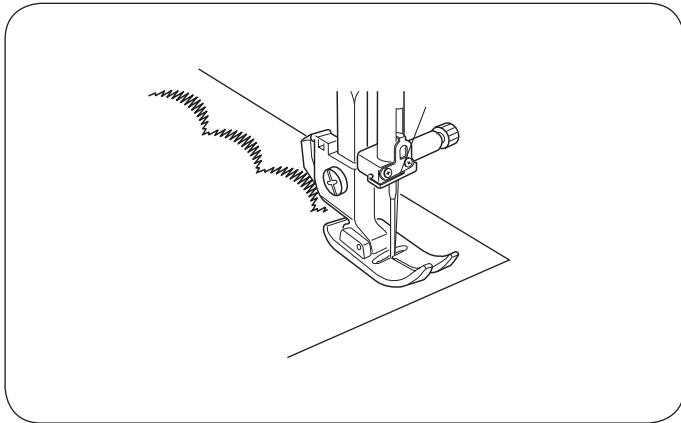

For a delicate appearance on fabric such as chiffon, use a single layer with a tear-away backing, if necessary.

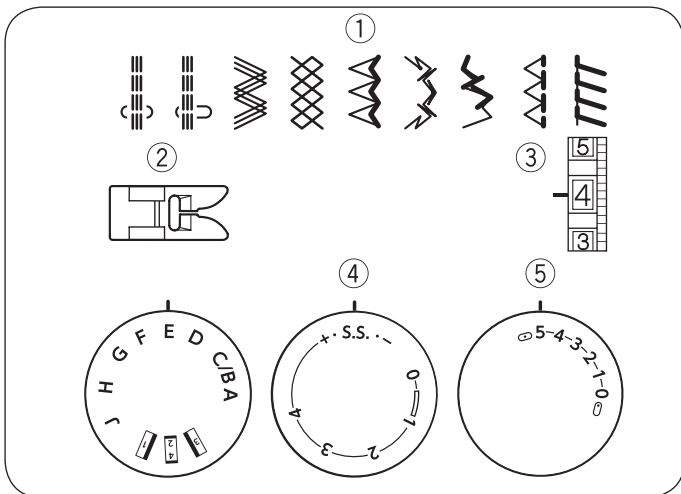

Decorative Stretch Stitches

Machine setting

- ① Stitch pattern: A - J
- ② Presser foot: Zigzag foot A
- ③ Thread tension: 3 - 6
- ④ Stitch length: S.S.
- ⑤ Stitch width: 3 - 5

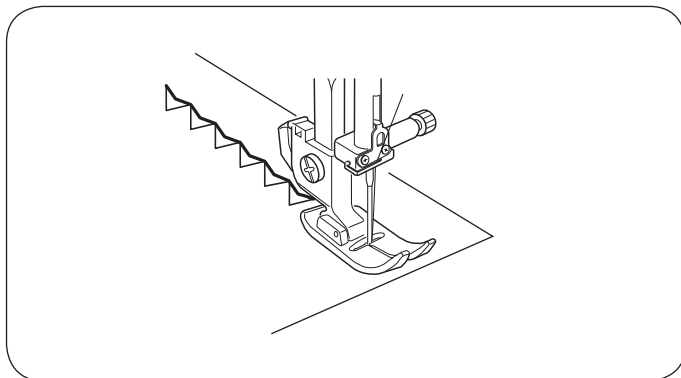

Decorative stretch patterns are used for adding a creative and personalized touch to items. Carefully guide the fabric while sewing as the fabric moves back and forth.

SECTION 6. CARE AND MAINTENANCE

WARNING:

Turn the power switch off and unplug the machine before cleaning.

NOTE:

Do not dismantle the machine in any way other than what is explained in this section.

Remove the setscrew by turning it counterclockwise with a screwdriver and remove the foot holder.

Cleaning the Hook Race and Feed Dog

- 1 Remove the presser foot and needle. Remove screw on the needle plate with the screwdriver. Remove the needle plate and take out the bobbin.

① Screw

- 2 Lift up the bobbin holder and remove it.

② Bobbin holder

- 3 Brush out dust and lint. Wipe the bobbin holder with a soft, dry cloth.

- 4 Clean the feed dogs and hook area with the lint brush.

③ Lint brush

④ Feed dogs

- 5 Wipe the hook race with a soft, dry cloth.

④ Hook race

NOTE:

You may also use a vacuum cleaner.

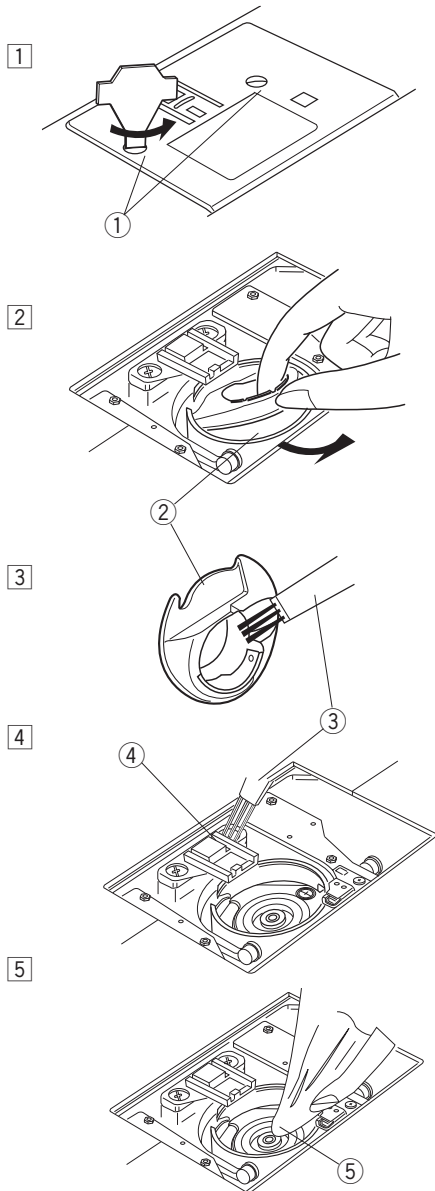

Replacing the Bobbin Holder

1 Insert the bobbin holder into the hook race.

2 Lift up the bobbin holder and remove it.

- 1 Knob
- 2 Stopper

3 Replace the bobbin.
Attach the needle plate.
Tighten the screw firmly with the screwdriver.

- 3 Screw

1

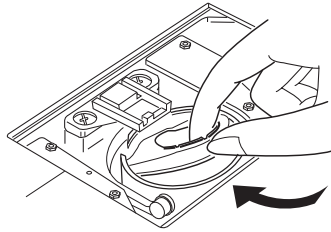

2

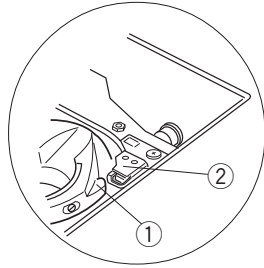

3

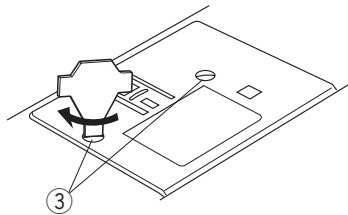

Troubleshooting

| Problem | Cause | Reference |
|----------------------------------|--|---|
| The needle thread breaks. | <ol style="list-style-type: none"> 1. The needle thread is not threaded properly. 2. The needle thread tension is too tight. 3. The needle is bent or blunt. 4. The needle is incorrectly inserted. 5. The needle thread and the bobbin thread are not drawn to the rear and set properly under the presser foot when starting sewing. 6. The fabric is not drawn to the rear when sewing is finished. 7. The thread is too heavy or too fine for the needle. | <p>See page 11. See page 14. See page 7. See page 7.</p> <p>See page 15. See page 15. See page 7.</p> |
| The bobbin thread breaks. | <ol style="list-style-type: none"> 1. The bobbin thread is not threaded properly in the bobbin holder. 2. Lint has collected in the bobbin holder. 3. The bobbin is damaged and does not turn smoothly. 4. The thread is wound loosely on the bobbin. | <p>See page 10 See page 30 Replace the bobbin. Re-wind the bobbin.</p> |
| The needle breaks. | <ol style="list-style-type: none"> 1. Needle is incorrectly inserted. 2. The needle is bent or blunt. 3. The needle clamp screw is loose. 4. A proper foot is not used. 5. The fabric is not drawn to the rear when sewing is finished. 6. The needle is too fine for the fabric being sewn. | <p>See page 7. See page 7. See page 7. Use proper foot. See page 15. See page 7.</p> |
| The needle thread loops. | <ol style="list-style-type: none"> 1. The needle thread tension is too loose. 2. The needle size is not suitable for the thread. | <p>See page 14. See page 7.</p> |
| Skipped stitches | <ol style="list-style-type: none"> 1. The needle is incorrectly inserted. 2. The needle is bent or blunt. 3. The needle and/or thread are not suitable for the fabric being sewn. 4. The needle thread is not threaded properly. 5. A poor quality needle is used. | <p>See page 7. See page 7. See page 7. See page 11. Replace the needle.</p> |
| Seam puckering | <ol style="list-style-type: none"> 1. The needle thread tension is too tight. 2. The needle thread is not threaded properly. 3. The needle is too heavy for the fabric being sewn. 4. The stitch length is too long for the fabric. <p>* Use a stabilizer for very fine fabrics.</p> | <p>See page 14. See page 11. See page 7. Make stitch shorter.</p> |
| The cloth is not fed smoothly. | <ol style="list-style-type: none"> 1. The feed dog is packed with lint. 2. The stitches are too fine. 3. The feed dog was not raised after being lowered. | <p>See page 30. Make stitch longer. See page 5.</p> |
| The machine does not work. | <ol style="list-style-type: none"> 1. The machine is not plugged in. 2. Thread is caught in the hook race. 3. The bobbin winder spindle is in the bobbin winding position. | <p>See page 4. See page 30. See page 9.</p> |
| Patterns are distorted. | <ol style="list-style-type: none"> 1. The stitch is not balanced. | <p>See page 13.</p> |
| The buttonhole is not sewn well. | <ol style="list-style-type: none"> 1. The stitch density is not suitable for the fabric being sewn. 2. Interfacing is not being used with stretch fabrics. | <p>See page 21. Use an interfacing.</p> |
| Noisy operation. | <ol style="list-style-type: none"> 1. The feed dog is packed with lint. 2. Lint has collected in the bobbin holder. | <p>See page 30. See page 30.</p> |

