

BABY LOCK SERGER ACCESSORIES

Double Fold Bias Binder

1-1/8 inch (28mm) (BLE8-S3)

1-1/2 inch (36mm) (BLE8-S2)

Instructions

This conventional binder will double fold and sew bias strips to your project in one quick step on the Evolve, using either a chain or coverstitch. Choose from two widths based on your preference.

MACHINE SETTINGS

Stitch type: 1-1/2"	Chain Stitch - C3 Needle Position C2-C3 Narrow Right Cover Stitch C2-C3
Stitch type: 1-1/8"	Narrow Right Cover Stitch Chain Stitch - C3 Needle
Stitch length:	3-4
Upper looper:	Down
Upper knife:	Disengaged "LOCKED"
Sewing table:	On

Bias Strip Cut Size:

1-1/8 inch Binder:

- Cut 1-1/8 inch bias from fine fabrics such as calico, muslin, etc.
- Cut 1 inch wide for medium weight fabrics such as trigger, lightweight denim.

1-1/2 inch Binder:

- Cut 1-3/8 inch for fine fabrics such as calico, muslin, etc.
- Cut 1-1/4 inch wide for medium weight fabrics such as trigger, lightweight denim.

Note: Test with fabric strip to make sure of correct width of bias.

Note: When using BLCS the accessory adaptor BLCS-AA is needed.



Instructions:

1. Secure attachment to table with guide fixing screws.
2. Cut fabric strips to size needed.
3. Raise presser foot. With the point of the bias strip, place strip into attachment. Use tweezers to feed the strip into the attachment.
4. Place the folded bias up to the needles and under the presser foot.
5. Turn the handwheel 3-4 times to secure the stitching in the fabric.
6. Place the fabric that is to be bound into the slot of the attachment. Place in the folded bias in front of the presser foot.
7. Loosen the guide fixing screws and move the attachment right or left to align the attachment with the needle position.
8. Sew test for proper alignment before sewing on project.

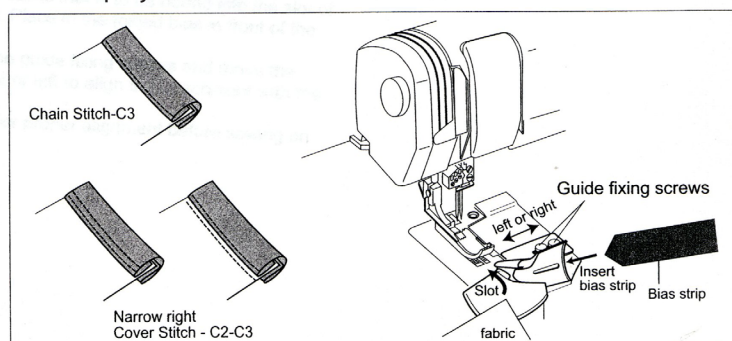

FOR THE LOVE OF SEWING