



Training:

HAPPY HCH-701 Operations & Maintenance For HCH Journey with Touch Screen

Chapter 1: Introduction: The Machine, Needle, and Thread

- **Introduction to your machine p.2**
 - Diagram of major parts p. 2
 - Diagram of major systems: Pantograph, sewing machine, color change/cut p.3
 - The Sewing Cycle p. 4
 - Machine environment p.5
- **Control Panel Introduction & Orientation p.6**
 - Power on/off / emergency stop
 - Power-on & navigating to the main sewing screen
- **Important Screens: A brief introduction p.7**
 - Drive screen 7
 - Important Sub Screens 8
 - Main menu, 9
- **Additional Basics p.10**
 - About stitches, sewing quality, stitch file formats
- **Embroidery Thread p. 11**
 - Installing thread p. 12
 - Bobbin thread p. 14
- **Embroidery Needles p. 15**
- **Hooping p. 16**

Introduction: A Quick Tour of the Machine

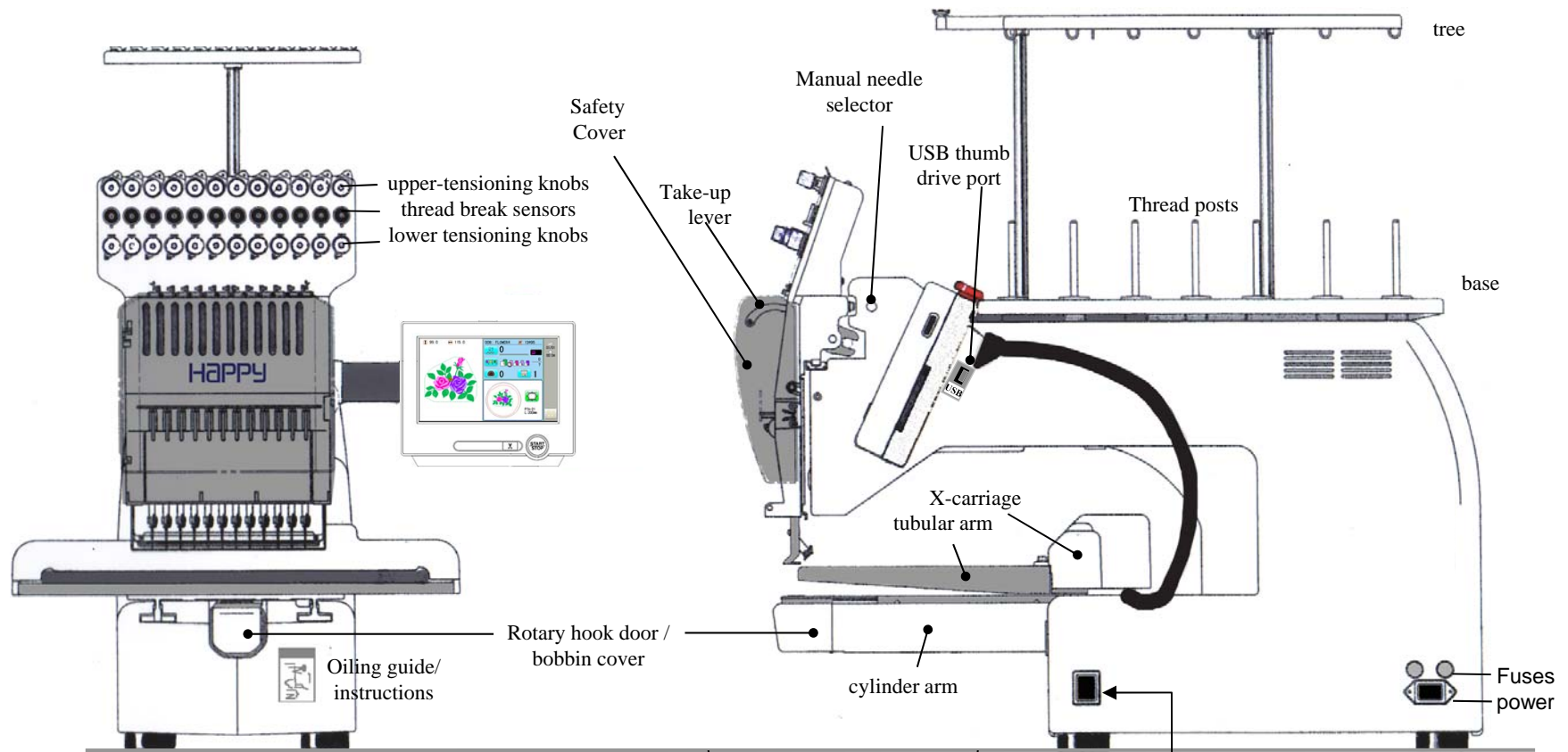

Table area beneath cylinder arm:: for tubular goods, table or other object under cylinder arm can provide support for the garment. However, the cap driver requires that the surface under the arm be at least 4" below level of feet.

Main power switch: Press and hold continuously for 1-2 sec. to power on

Introduction: 3 key mechanical systems

1. Color Change System

Moving head
Thread cut system

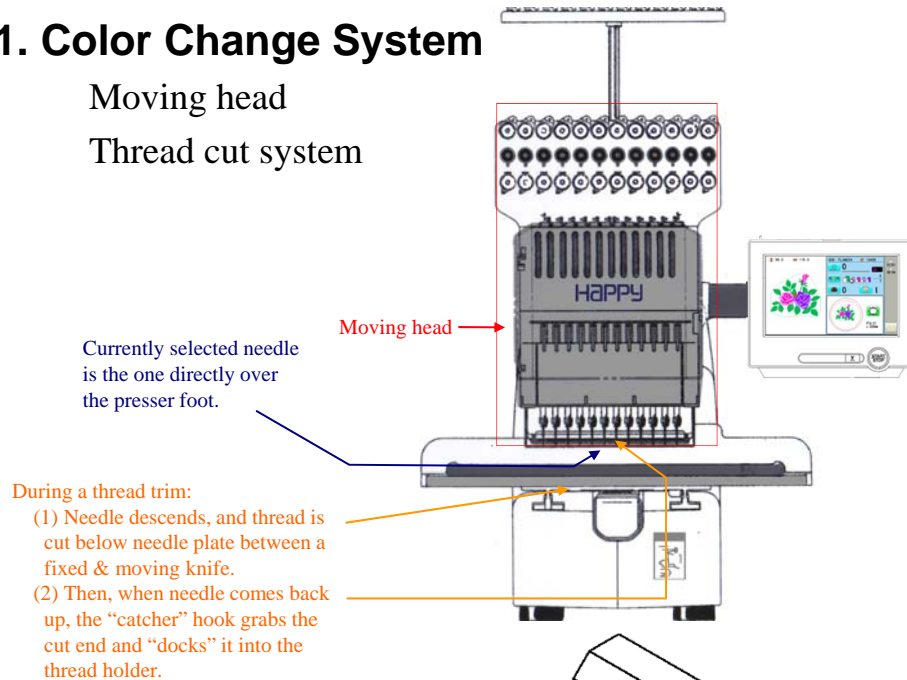

2. Sewing System

Take-Up Lever
Needle bar
Rotary hook / bobbin

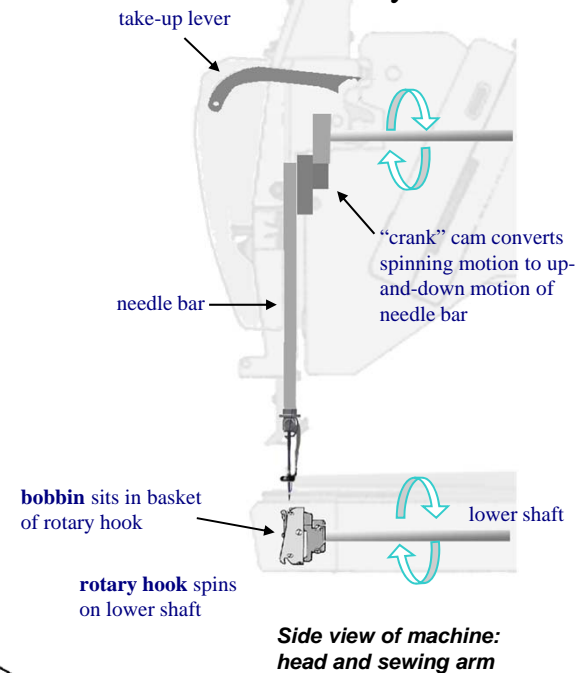

3. X-Y Pantograph

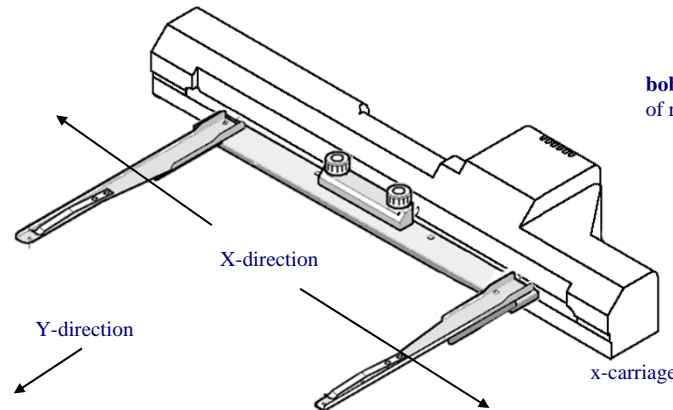

Basics: Lock Stitch Formation (sewing cycle)

Lock Stitch Illustrated.

Notice how the top thread only half-loops with the bobbin thread for every stitch

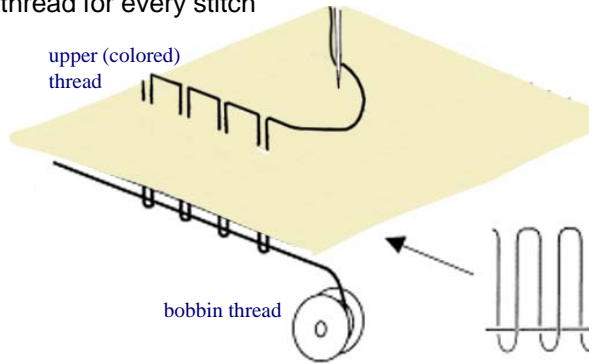

Role of the Presser Foot in Loop Formation

Note how the presser foot (shown in grey) helps the loop open as the needle starts back up.

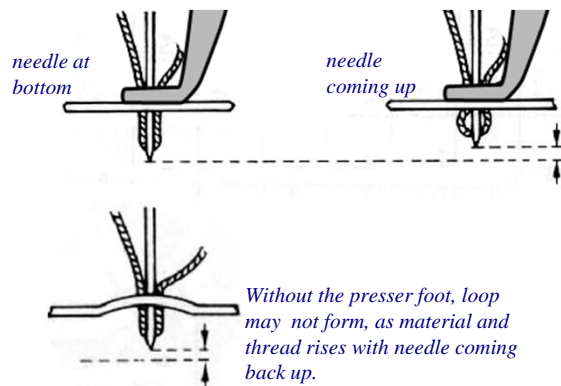

How Each Part of the Cycle Works

The key parts of the sewing cycle.

Take Up Lever:

At the start of the cycle, the take-up lever lowers to allow enough slack for the loop to form. After the hook catches the colored thread and makes the half-twist, it pulls back up to take up the slack and close the loop to finish the stitch.

Presser Foot – presses down on the garment surface to allow cleaner entry of the needle. Also remains still as the needle starts to lift to help the loop form (see illustration at left.)

Needle – Pushes a half-loop of thread below the garment surface. Then, as it starts back up, the slack causes the loop to open, allowing the rotary hook (below) to pass behind the needle and grab the thread.

Rotary Hook – spinning point reaches behind the needle eye, hooks the colored thread, spins/twists it around the bobbin thread to form the loop.

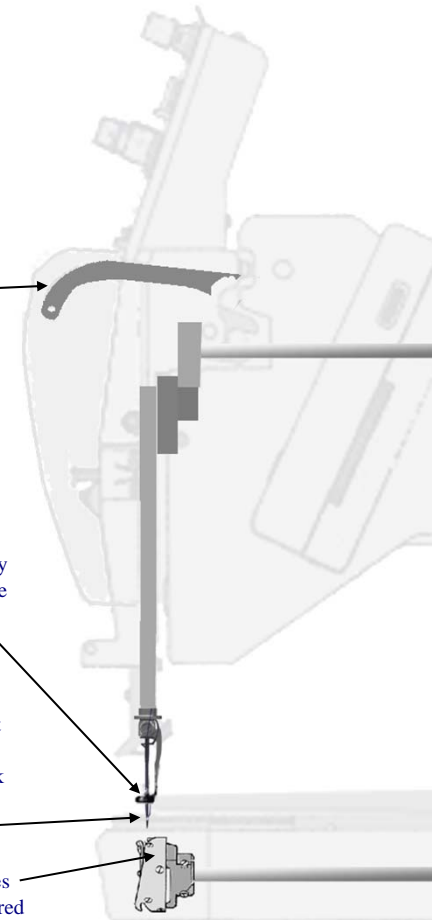

Proper Machine Environment

Temperature and Humidity-Controlled Environment

Set up/store your machine in a temperature and humidity-controlled environment to prevent long-term corrosion and to protect the electronics. Don't keep your machine anywhere you wouldn't keep a laptop or desktop computer !

Clean, Protected Electrical Power

grounded outlets: Your machine uses standard 110v household current. Be sure you connect it to a grounded 3-prong outlet like the one shown here. This is standard in most homes and businesses today, but some older buildings may only have 2-prong outlets.



Standard
3-prong
110v
outlet



Basic surge
protector

surge protection: Protect your machine against occasional power spikes (from electrical storms or electrical wiring problems) with at least a basic surge protector. The electronics on your machine can be very expensive to replace. Higher-end surge protectors and UPS units are able to protect against higher energy strikes, and often come with a guarantee.

Steady Table / Mounting Surface

Your machine will perform better (especially at higher speeds) when operated on a strong, level and steady mounting surface. Although on wheels, the optional stand provides plenty of stability, and even more when the wheels are rotated to their outermost positions and the brakes are applied at all 4 corners.



Optional machine stand with accessory
shelf, casters and wheel brakes

Control Panel Intro: Power On to the Main (Drive) Screen

Power On

Power on your machine with the black switch located on the side of the machine.
The screen below appears.

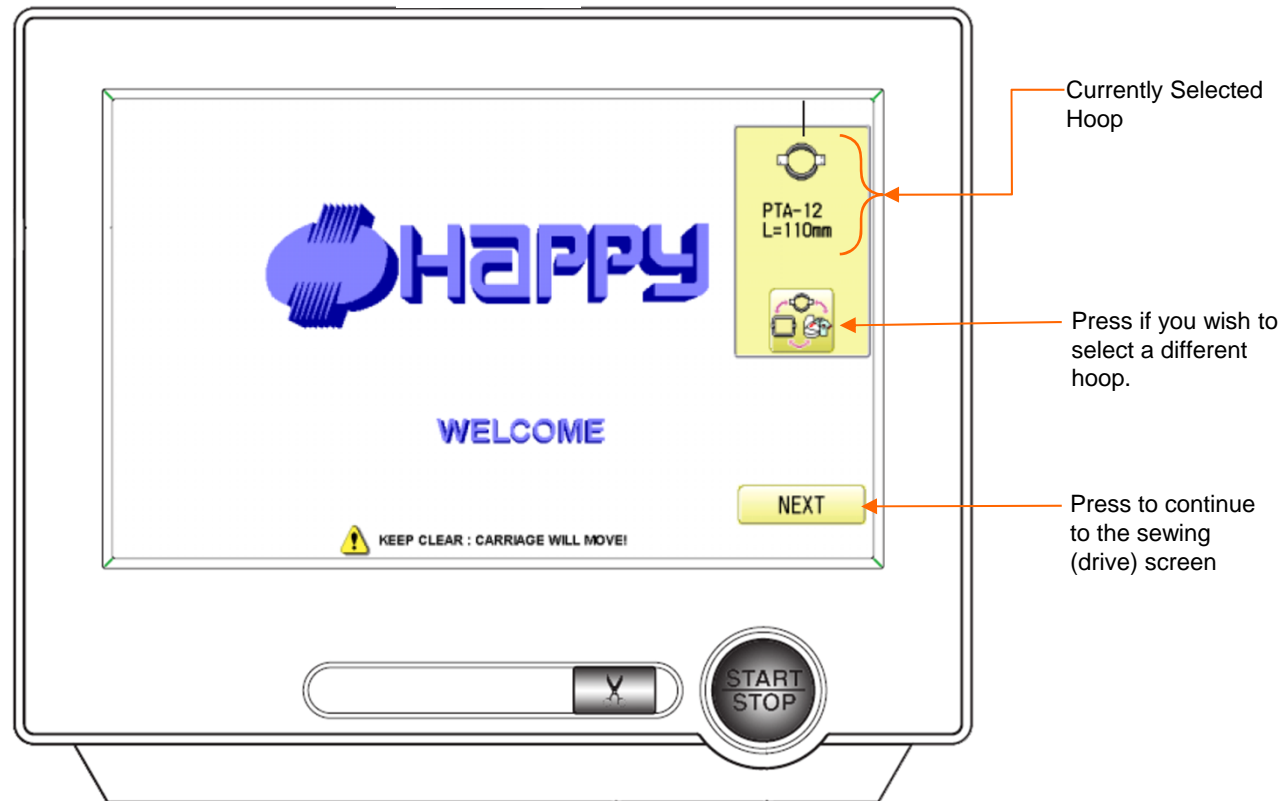

Control Panel Intro: Power On to the Main (Drive) Screen

The Sewing/Drive Screen

This is the main “drive” screen. The machine needs to be in this mode to sew or to accept design transfers by PC connection. Note the important information shown in the Drive screen here. This is the only screen where this information is displayed.

- Current stitch position # is 0
- Current color block # is 1
- Current sewing speed is 0

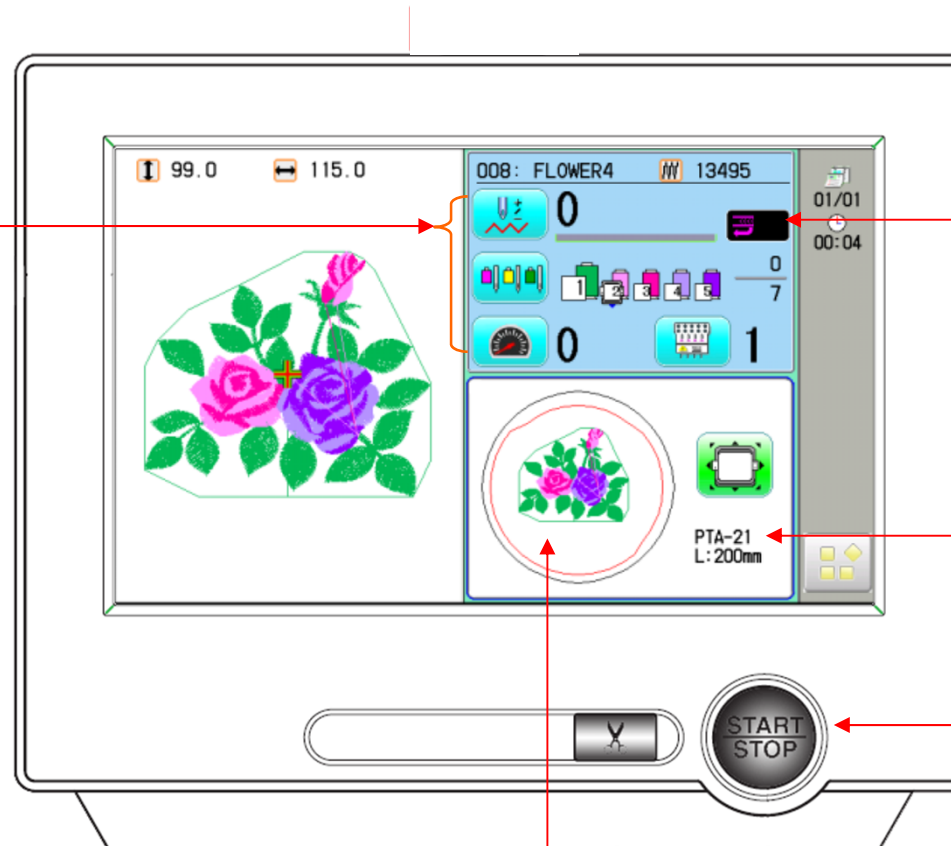

Origin Symbol:
means the sewing position is at the origin (beginning).

Current Hoop:
shows what type of hoop has been selected.

Lights in green
when the machine is ready to sew.

Design position and fit in the hoop

Control Panel Intro: Other Important Screens

Shown below are the important subscreens directly accessible from the Drive screen by a single button:

Sewing Position Screen
Jump to any position in the design using this screen, by piece #, by color block# or by stitch#.

Needle Selector
Select a different needle, toggle jump/drive mode.

Set Colors for Current Design
Assign needle (color) numbers, applique stops, frame out commands in the design.

Adjust Max Speed
During sewout or while stopped.

Select hoop, Adjust Sewing Position
By selecting the hoop you're being used, the machine accurately displays the position in the hoop.

Control Panel Intro: Other Important Screens

The Main Menu

The other - and most important - menu is the Main Menu, accessed from the main Drive screen by pressing MENU as shown below.

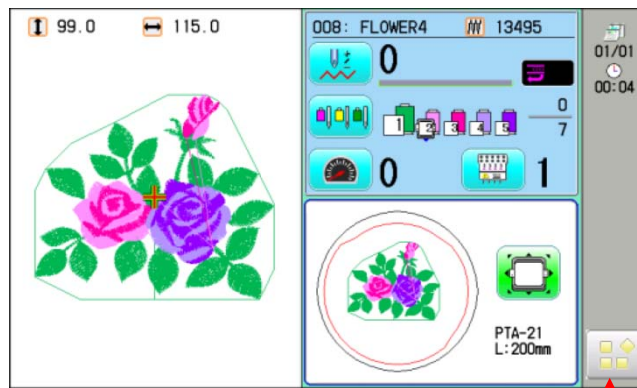

Press this **menu** button to get to the main menu.



Press the **Home** button to exit to the main (drive) screen.

Summary of Main Menu Sub-screens:

- READ – read in designs from thumb drive or from PC via network cable
- PATTERN – view/select/delete/rename etc designs in memory
- NEEDLE – set design colors (can be done from Drive screen as well)
- FRAME – select hoop (can be done from Drive screen as well)
- SETTING – perform basic edits/adjustments to the current design
- OPTION – adjust settings for machine, designs and stitch data
- LETTER – onboard lettering feature
- QUEUE – queue a sequence of designs to be sewn.
- OTHER – date/time, network, machine reset, version/update
- REPORT – machine production report
- GUIDE – onboard help

- iCUSTOM – Customize drive screen icons (like a tablet or smart phone)
- SCREEN – screensaver settings – select your own images, time, etc.



Other Basics

- **About Stitches :**
 - **Max and minimum length:** Must be between 1mm (.04 inch) and 12.7mm (1/2 inch). Too short causes thread breaks. Too long, stitches are too loose.

- **Major Factors Affecting Sewing Quality that you can control:**
 - **Tension** – once properly set, should rarely require re-adjustment. We will cover this in class.
 - **Hooping** – proper hooping is a must. Not too tight, not too loose. We will cover this in class.
 - **Digitizing** – hire a digitizing service and/or learn how to digitize in digitizing classes.
 - **Machine Adjustments** – we will show (Chapter 4) how check key adjustments to maintain performance.

- **Sewing file format used in commercial embroidery: DST**
 - All commercial machines read this format
 - Does not have color information – must load the design into the machine AND tell it which colors to sew.
 - Limited in editability. Not resized or adjusted easily for different types of garments without compromising quality.
 - Happy machines will also read HAPPY (.TAP) and Melco (.EXP) format.

Embroidery Thread

- **Upper (colored) thread**
 - Can be polyester or rayon, usually polyester. Standard is 40 weight
 - Comes in several sizes: 5,000 meter cones to 1,000 meter cones.
 - Handle carefully: physical contact, oil, dust, humidity, moisture can prevent it from unspooling smoothly, and cause it to “hang up”
 - Use thread cone stabilizers (plastic springs) to minimize cone movement during sewing

- **Bobbin thread**
 - L-type, approximately 350 yards per spool. Bobbin thread will have to be changed more frequently than upper thread.
 - Lasts approximately 25,000 to 60,000 stitches, depending on fabric thickness, thread tension and other factors.

Typical 5000 meter “king” cone of thread



These stabilizers help prevent thread from unraveling or catching.



Embroidery Thread Installation of upper thread on your machine

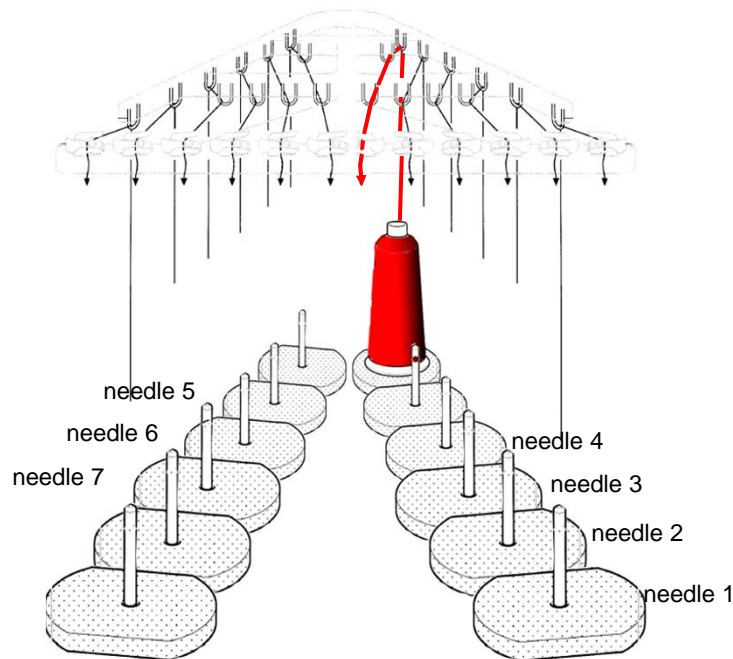

Layout of Cone/Needle Sequence

Needle numbers are arranged right to left, lowest number to highest.

Replacement cones can be tied in here and pulled through so the thread doesn't have to be run manually through the thread path. (See next page)

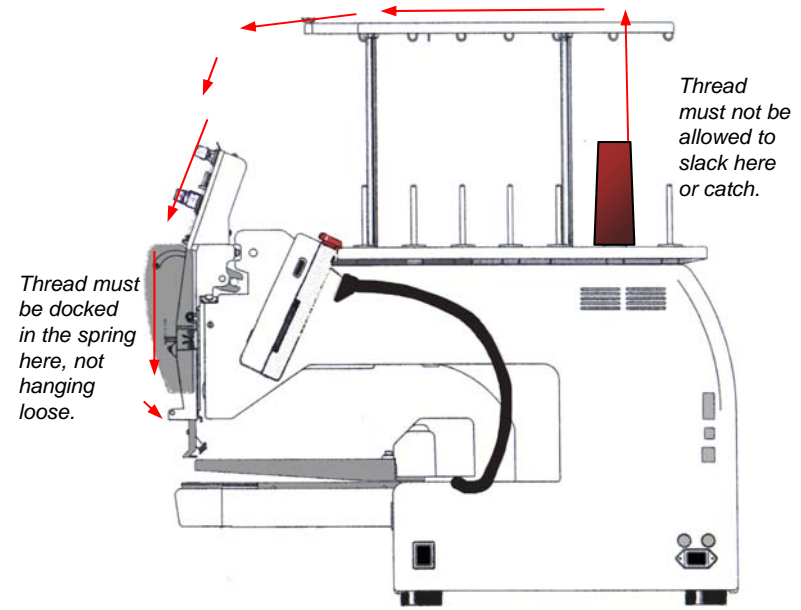

General Thread Path

Thread should be properly, perfectly routed from cone to needle or it will not feed properly and stop the machine.

Embroidery Thread Thread Path through the moving head

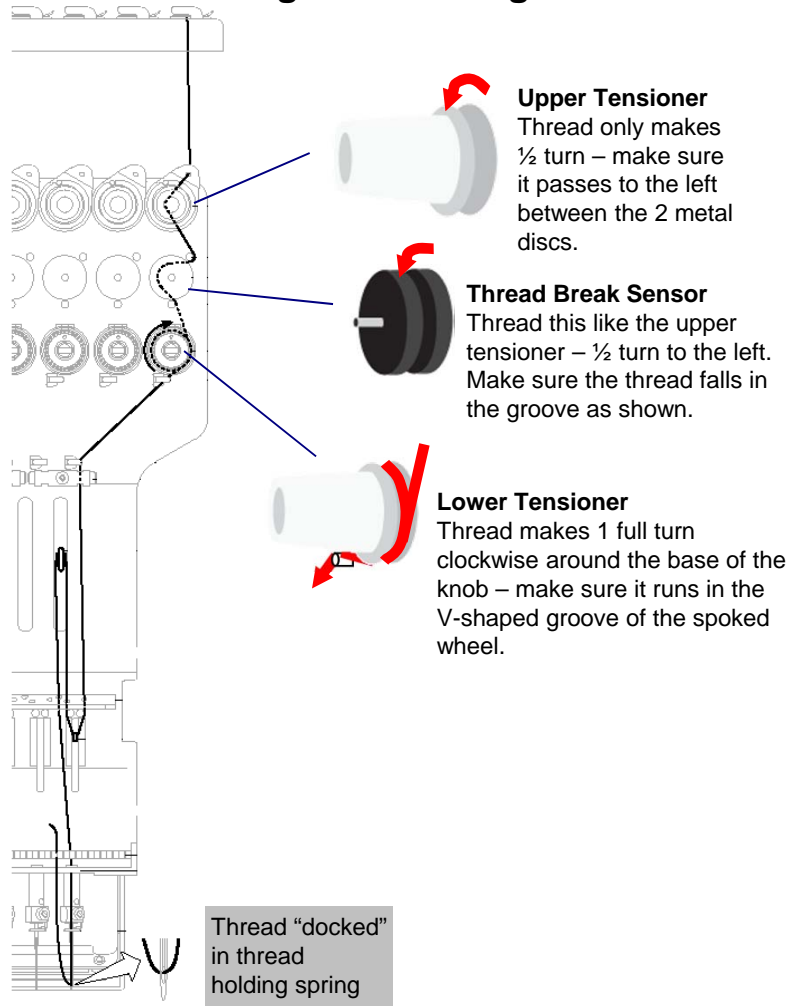

-Proper Thread Routing: All threads **must** be routed correctly at all points along the path through the sewing head.

-Practice good thread “Discipline”: After threading all needles, ensure there is no slack anywhere along the thread path. Make sure to:

- ***Pull all threads*** – to ensure thread feeds smoothly and turns the break sensor, and all slack is removed from around thread cones
- ***“Dock” all thread ends*** from each needle onto the thread-holding spring. Prevents thread from coming loose and catching where not desired.

Embroidery Thread

Bobbin Loading and Tension Check/Adjustment

RE-LOADING THE BOBBIN CORRECTLY

The bobbin will need to be replaced frequently, allowing only 30,000 to 60,000 stitches per spool. This has to be done correctly every time.



1. Ensure bobbin turns clockwise. Pull thread through this slit.



2. Feed thread through eye at the end of the tension flap.



3. Check tension with the "drop" test (explained lower left).



4. Pass thread through the wire loop at the top front of the bobbin case. Do this after you're satisfied with tension, and before inserting into the machine.

CHECKING TENSION WITH THE "DROP" TEST.

1. **Hold the bobbin case as shown in step 3**, after feeding the thread through the eye at the end of the tension flap.
2. **"Cast" the bobbin case downward gently**, very much like throwing a yo-yo.
3. **Good tension:** Upon stopping your hand, the slight downward momentum of the bobbin case should cause it to unspool and continue downwards slightly and stop. (If downward motion of your hand causes the bobbin to jump out of the case, try again but more gently).
4. **Wrong tension:** If the bobbin doesn't unspool at all, tension is too tight. If the bobbin unspools on its own when held like in step 3, tension is too loose. Make adjustments if needed as shown on the right.

With a working bobbin case and a properly loaded bobbin, this test reliably tests to 25g on a bobbin tension gauge, precise within 1g. Perform this quick check each time you re-load the bobbin until you are comfortable with tension.

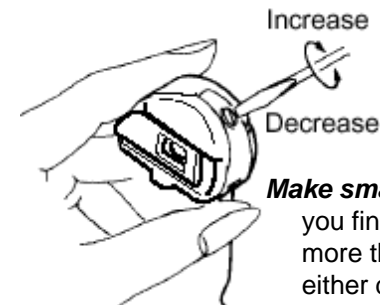

Make small adjustments if you find it necessary. – no more than a ¼ or ½ turn in either direction before re-checking tension.

5. TAKE CARE TO RE-INSERT THE RELOADED BOBBIN CASE FULLY after re-loading or the machine will not function correctly.

Embroidery Needles

- **Type DB-K5, standard size is 75/11 ballpoint for most applications.** Alternate needle for sewing caps and other tightly-woven goods (heavy canvas) is 80/12 sharp point for better penetration
- **The width of the shaft of an embroidery needle** limits the the finest possible detail (the smallest possible stitch). Standard size (75/11) needles are .75 mm across, so stitches must be at least a little wider than the hole that the needle punches in the fabric (minimum distance 1mm)
- **Needles are subject to wear!** Over time, burred surfaces and other wear can cause problems. Be prepared to change needles frequently especially with heavy use.

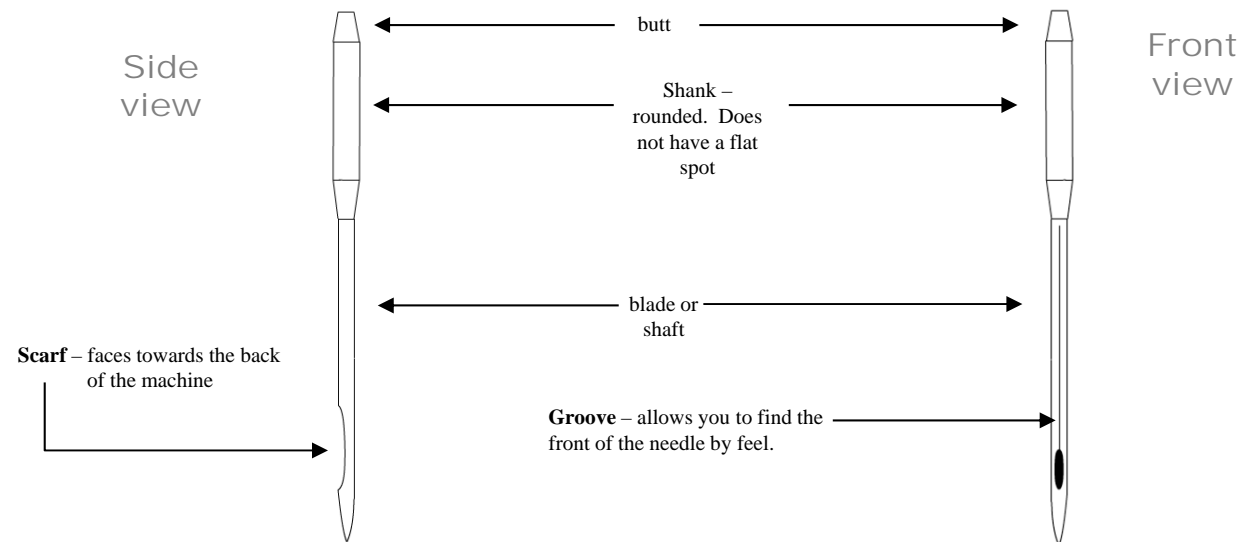

Key Embroidery Basics (continued)

Garment: Hooping and Loading on the Machine

– Hooping

Refer to the image of the Needle (color setup) screen shown on the right:

- **Hoop:** Use the smallest that fits the design size.
- **Backing/Stabilizer:** Choose the right type. Should be large enough to overlap edges of hoop under the garment.
- **Alignment and position:** If the hoop isn't aligned on the garment, it won't sew straight!
- **Round holes at bottom:** Make sure hoop is on the shirt so the round holes are towards the operator. Opposite end is towards machine.
- **Tight but not too tight!** Garment and backing should have no slack or wrinkles inside hoop. Adjustment screw tightened enough to hold garment in hoop while sewing, but no more.

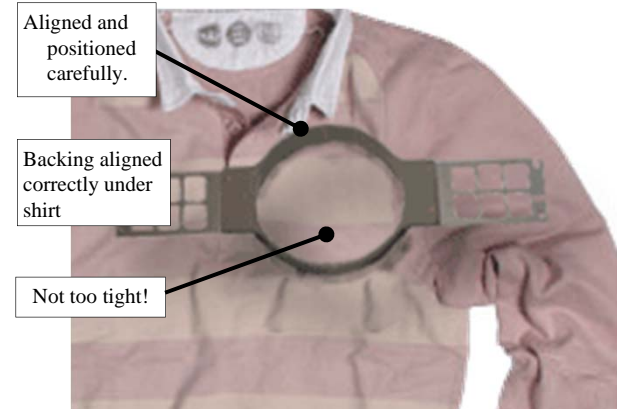
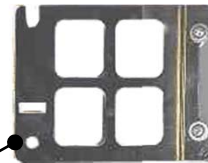

– Loading onto the Machine

Referencing the diagram on the right,

- **Positioning pins on arm** must snap into round holes on end of hoop to prevent unhooping during sewing.
- **Sewing arm goes INSIDE the garment, not UNDER,** or machine will sew front and back of garment together!
- **Loose items tucked out of the way.** (sleeves, straps, etc)
- **Heavy items supported where possible** to prevent item from falling out of hoop. Sleeves, and body can rest on table or chair underneath or to the side of machine if needed. Reinforce hoop with clamps or tape if needed.

