

ENGLISH





LK-1900AN

LK-1901AN LK-1902AN

LK-1903AN LK-1903AN-305

INSTRUCTION MANUAL

CONTENTS

I . EXPLANATION OF LK-1900AN, COMPUTER-CONTROLLED HIGH-SPEED BARTACKING MACHINE	1
[1] SPECIFICATIONS	1
[2] CONFIGURATION	2
1. Names of main unit.....	2
2. Names and explanation of switches on the operation panel	3
[3] INSTALLATION	4
1. Installing the electrical box.....	4
2. Attaching the connecting rod.....	4
3. Installing the head support rod	4
4. Installing and connecting the power switch	5
5. Installation of the sewing machine head.....	6
6. Installing the drain receiver and the head support rubber.....	6
7. Safety switch.....	7
8. Tilting the sewing machine head	7
9. Installing the operation panel.....	8
10. Connecting the cord.....	9
11. Installing the motor cover	10
12. Managing the cord.....	11
13. Installing the eye protection cover	11
14. Installing the thread stand.....	12
[4] OPERATION OF THE SEWING MACHINE	13
1. Lubrication	13
2. Attaching the needle	13
3. Threading the machine head.....	14
4. Installing and removing the bobbin case.....	14
5. Installing the bobbin.....	15
6. Adjusting the thread tension.....	15
7. Adjusting the thread take-up spring.....	16
8. Example of the thread tension	16
[5] OPERATION OF THE SEWING MACHINE (BASIC)	17
1. Item data setting	17
2. Checking the contour of a sewing pattern.....	19
3. Sewing	20
4. Change to the other sewing pattern	20
5. Winding a bobbin.....	21
6. Thread clamp device	22
[6] OPERATION OF THE SEWING MACHINE (ADVANCED)	24
1. Performing sewing using the pattern keys ( ,  ,  ,  and ).....	24
2. Performing sewing using the combination function.....	27
3. Performing sewing using the “bobbin thread counter”.....	29
4. How to use the temporary stop	29
5. Setting the pattern thread tension	30
6. Cautions in operation.....	31
[7] MAINTENANCE	31
1. Adjusting the height of the needle bar	31
2. Adjusting the needle-to-shuttle relation.....	32
3. Adjusting the lift of the work clamp foot.....	33
4. The moving knife and counter knife	33
5. Needle thread clamp device	34
6. Adjustment of the wiper.....	34
7. Draining waste oil.....	35
8. Amount of oil supplied to the hook	35
9. Replacing the fuse.....	35

10. Changing the voltage of 100/200V	36
11. Replenishing the designated places with grease.....	37
[8] HOW TO USE THE MEMORY SWITCH.....	38
1. Start and change of the memory switch.....	38
2. Example of the memory switch setting	38
3. Table of functions of the memory switch	42
[9] OTHERS	45
1. Setting the DIP switch	45
2. Table of the standard pattern specifications	46
3. Table of the standard patterns	47
4. Table of the work clamp foot	49
5. LK-1900 data ROM	51
6. Connection of the optional pedal.....	51
7. Error list.....	52
8. Troubles and corrective measures (sewing conditions).....	55
9. Table of the optional parts	57
II . EXPLANATION OF THE LK-1901AN, COMPUTER-CONTROLLED HIGH-SPEED EYELET BUTTONHOLE BARTACKING MACHINE	59
1. Specifications	59
2. Installation of the sewing machine and preparation of the operation.....	59
3. Adjustment of the material closing amount.....	60
4. Adjustment of the lift of the work clamp foot	60
5. Adjustment of the pressure of the work clamp unit.....	61
6. Setting of the material closing operation	61
7. Selection and confirmation of the sewing patterns	62
III . EXPLANATION OF THE LK-1902AN, COMPUTER-CONTROLLED HIGH-SPEED BELT-LOOP ATTACHING MACHINE	63
1. Specifications	63
2. Installation of the sewing machine and preparation of the operation	63
3. Threading the machine	63
4. Selection and confirmation of the sewing patterns	64
5. Combination of the work clamp foot and the feed plate.....	64
IV . EXPLANATION OF THE LK-1903AN, COMPUTER-CONTROLLED HIGH-SPEED LOCKSTITCH BUTTON SEWING MACHINE	65
1. Specifications	65
2. Installation of the sewing machine and preparation of the operation.....	65
3. Needle and thread.....	65
4. Various sewing modes	66
5. Position of the button clamp jaw lever	67
6. Adjusting the feed plate	68
7. Adjusting the button clamp jaw lever	68
8. Adjusting the lifting amount of the button clamp.....	69
9. Adjustment of the pressure of the work clamp unit.....	69
10. Adjustment of the wiper spring.....	70
11. Installing the save button bar (accessory part).....	70
12. Model classification according to the button size.....	71
13. Attaching the shank botton (optional).....	72
V . DRAWING OF THE TABLE.....	76

I . EXPLANATION OF LK-1900AN, COMPUTER-CONTROLLED HIGH-SPEED BARTACKING MACHINE

[1] SPECIFICATIONS

1	Sewing area	X (lateral) direction 40 mm Y (longitudinal) direction 30 mm
2	Max. sewing speed	3,200 sti/min* (When sewing pitches are less than 5 mm in X-direction and 3.5 mm in Y -direction.)
3	Stitch length	0.1 to 10.0 mm (adjustable in 0.1 mm step)
4	Feed motion of work clamp foot	Intermittent feed (2-shaft drive by stepping motor)
5	Needle bar stroke	41.2 mm
6	Needle	DP x 5, DPx17
7	Lift of work clamp foot	13 mm (standard) Max. 17 mm
8	Shuttle	Standard semi-rotary hook (oil wick lubrication)
9	Lubricating oil	New Defrix Oil No. 2 (supplied by oiler)
10	Data recording	EEPROM (128Kbyte) EPROM (32kbyte)
11	Enlarging / Reducing facility	20% to 200% (1% step) in X direction and Y direction respectively
12	Enlarging / Reducing method	Pattern enlargement / reduction can be done by increasing/decreasing the stitch length
13	Max. sewing speed limitation	400 to 3,200 sti/min* (100 sti/min steps)
14	Pattern selection	Specifying pattern No. type (1 to 200)
15	Bobbin thread counter	UP/DOWN type (0 to 9999)
16	Sewing machine motor	Servo motor
17	Dimensions	W : 1,200 mm L : 660 mm H : 1,100 mm (Use the standard table and stand.)
18	Weight	Machine head 42 kg, Control box 16.5 kg
19	Power consumption	450 VA (Pattern No. 1, 3,200 sti/min, 1-sec pause time)
20	Operating temperature range	5 °C to 35 °C
21	Operating humidity range	35% to 85% (No dew condensation)
22	Line voltage	Rated voltage \pm 10% 50/60 HZ
23	Noise	- Equivalent continuous emission sound pressure level (L_{pA}) at the workstation : A-weighted value of 82.5 dB; (Includes $K_{pA} = 2.5$ dB); according to ISO 10821- C.6.3 -ISO 11204 GR2 at 3,200 sti/min for the sewing cycle, 1.0s ON (Pattern : No.1). - Sound power level (L_{WA}) ; A-weighted value of 90.5 dB; (Includes $K_{WA} = 2.5$ dB); according to ISO 10821- C.6.3 -ISO 3744 GR2 at 3,200 sti/min for the sewing cycle, 1.0s ON (Pattern : No.1).

* Reduce the max. sewing speed in accordance with the sewing conditions.

Max. sewing speed of LK-1900ANWS (double capacity hook) is 2,700 sti/min.

[2] CONFIGURATION

1. Names of main unit

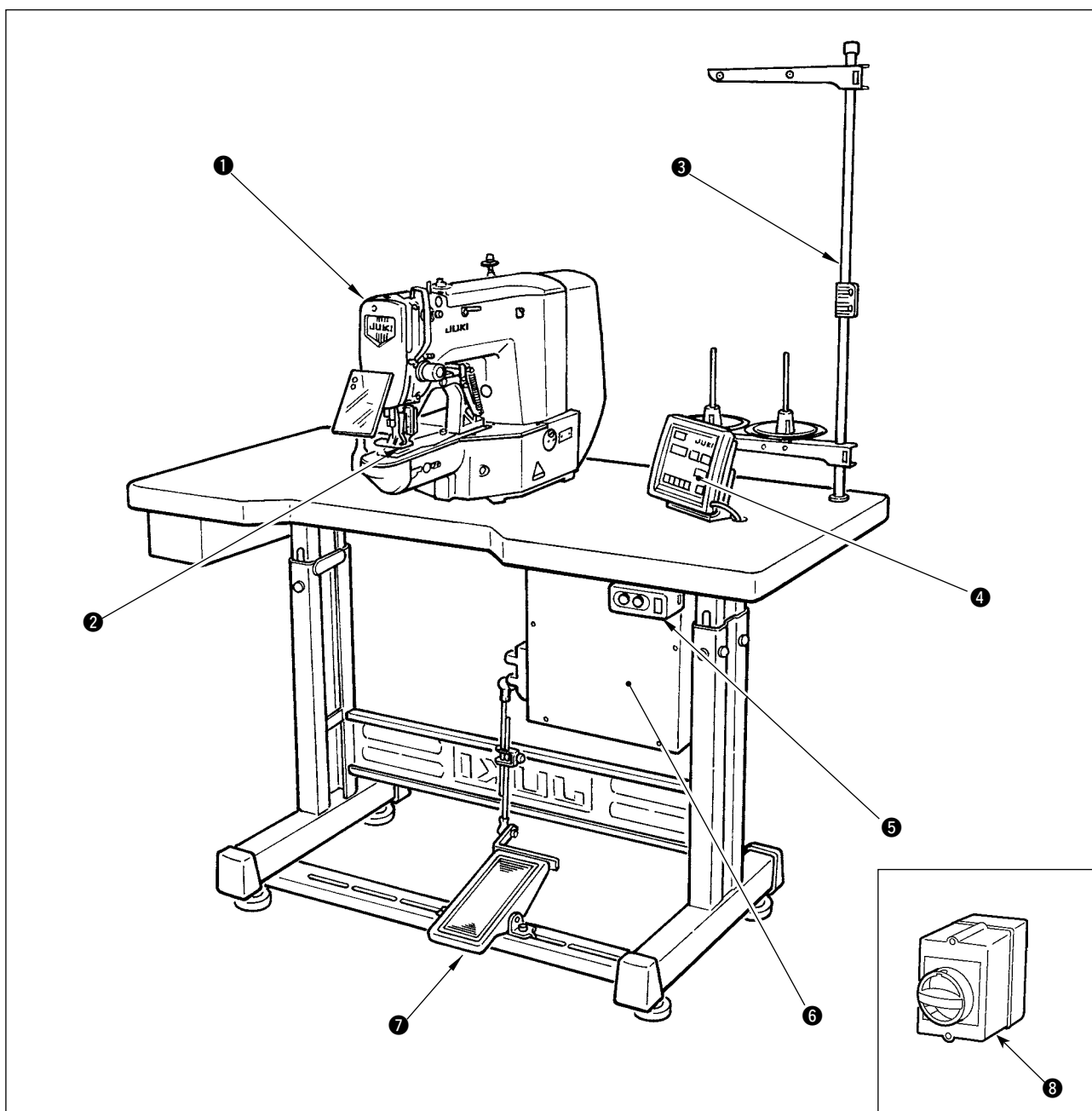

- ① Machine head
- ② Work clamp feet
- ③ Thread stand
- ④ Operation panel
- ⑤ Power switch
- ⑥ Control box
- ⑦ Pedal switch
- ⑧ Power switch (EU type)

2. Names and explanation of switches on the operation panel

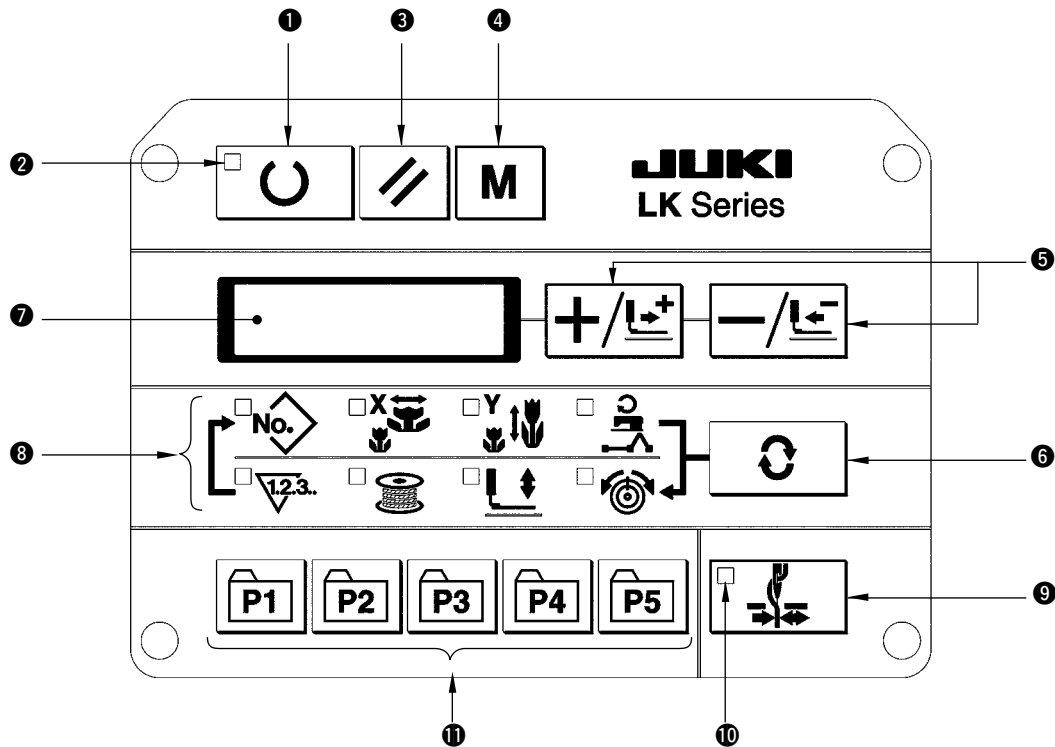

1 “Ready” key

This key changes over the setting state from the panel to the sewing state where the sewing machine actually operates.

2 Sewing LED

This LED goes off at the time of setting state and lights up at the time of sewing state. Changeover can be performed with “Ready” key.

3 “Reset” key

This key is used for canceling error or returning the set value to the initial value.

4 “Mode” key

This key makes the setting mode of the memory switch.

5 “+ / Feed forward” key and “- / Feed backward” key

This key is used for changing pattern No. and X/Y scale, and feed forward/feed backward.

6 “Selection” key

This key selects the item to be set. Item selection LED of the selected item and the set value are displayed.

7 Data indication LED

This LED indicates the set values of the selected items such as pattern No., X/Y scale, etc.

8 Item selection LED

LEDs of the selected items light up.



Pattern No.



X scale



Y scale



Max. speed limitation



Sewing counter



Bobbin winder



Work clamp foot lowering



Thread tension

9 Needle thread clamp ON/OFF key

This key selects effective/ineffective of needle thread clamp. When it is effective, needle thread clamp display LED lights up. **(Note 1)**

10 Needle thread clamp display LED

When this LED lights up, needle thread clamp operates.

11 Needle thread clamp display LED

This key registers the pattern. When this key is pressed, the pattern registered here can sew immediately. X/Y scale, sewing position, etc. can be changed and registered.

(Note 1) LK-1903AN is set to needle thread clamp prohibited (no motion) with memory switch No. 35 at the time of standard delivery.

[3] INSTALLATION

1. Installing the electrical box

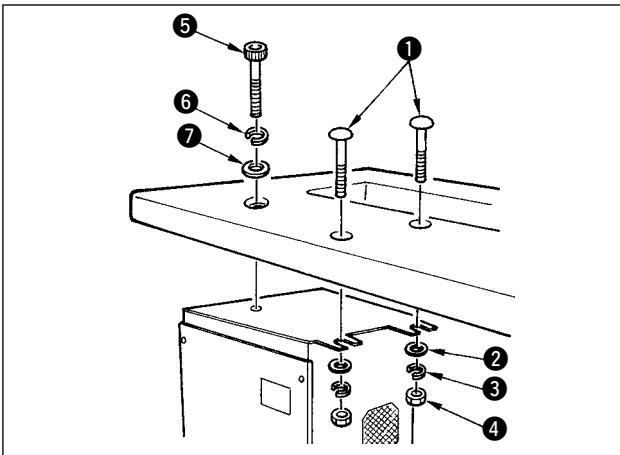

Install the electrical box on the underside of the table at the location illustrated using round-head bolt ①, plain washer ②, spring washer ③ and nut ④ supplied with the machine, and using bolt having hexagonal indentation on the head ⑤, spring washer ⑥ and plain washer ⑦ supplied with the machine.

2. Attaching the connecting rod

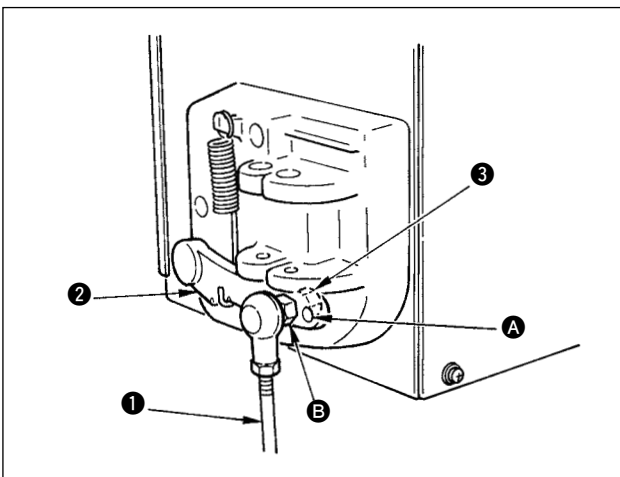

- 1) Fix connecting rod ① to installing hole B of pedal lever ② with nut ③.
- 2) when connecting rod ① is installed in installing hole A, the depressing stroke of the pedal is increased.

3. Installing the head support rod

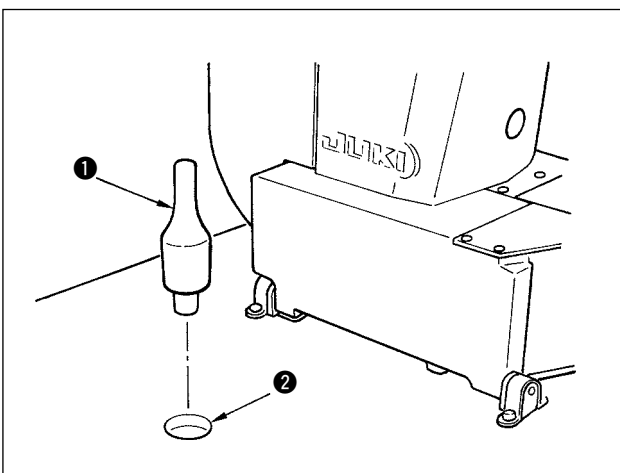

Drive head support rod ① in hole ② in the machine table.

4. Installing and connecting the power switch

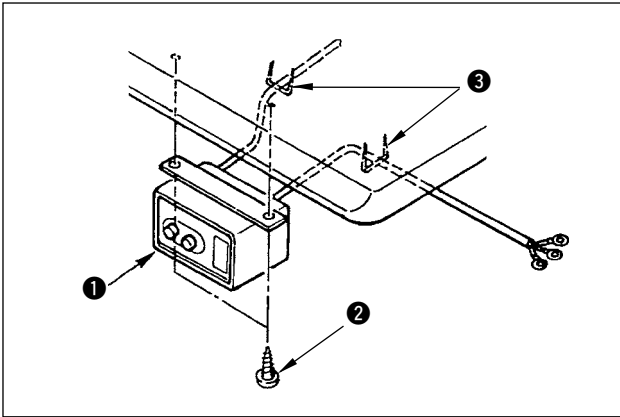

(1) Installing the power switch

Fix power switch ① under the machine table with wood screws ②.

Fix the cable with staples ③ supplied with the machine as accessories in accordance with the forms of use.

* Five staples ③ including the staple for fixing the operation panel cable are supplied as accessories.

(2) Connecting the power source cord

Voltage specifications at the time of delivery from the factory are indicated on the voltage indication seal. Connect the cord in accordance with the specifications.

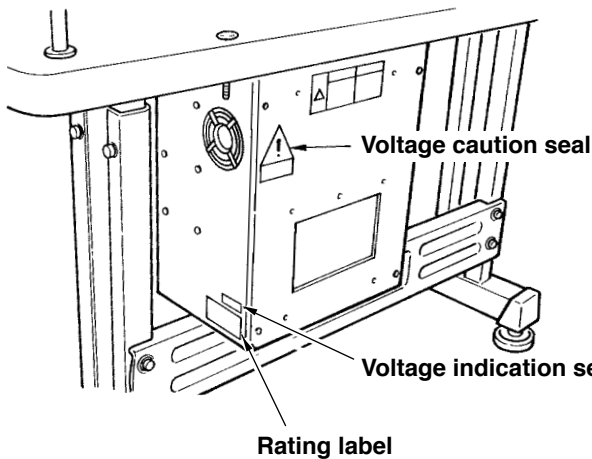

- 1. Never use under the wrong voltage and phase.**

2. When changing the voltage, refer to the item of " I .[7]-10. Changing the voltage of 100 / 200V" p.36.

• Connecting single phase 200V, 220V, 230V and 240V

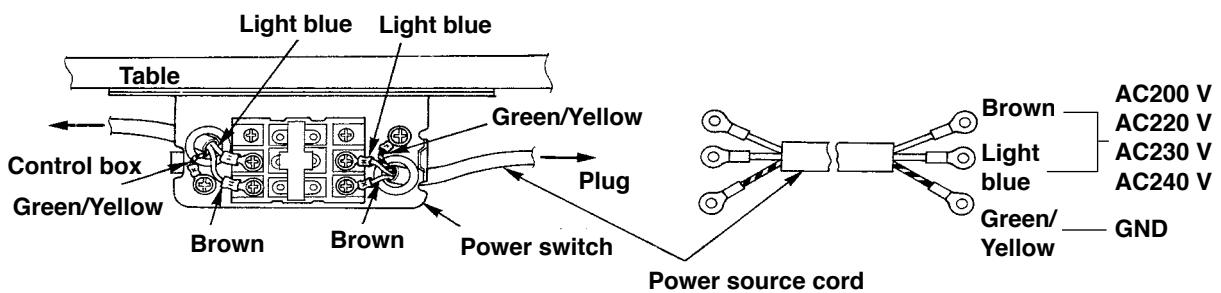

• Connecting three phase 200V, 220V and 240V

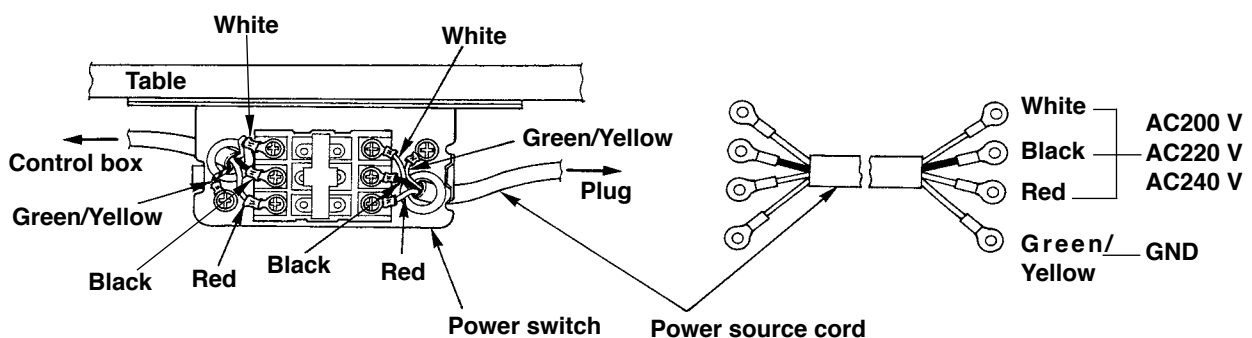

5. Installation of the sewing machine head



WARNING :

To prevent possible accidents caused by the full of the sewing machine, perform the work by two persons or more when the machine is moved.

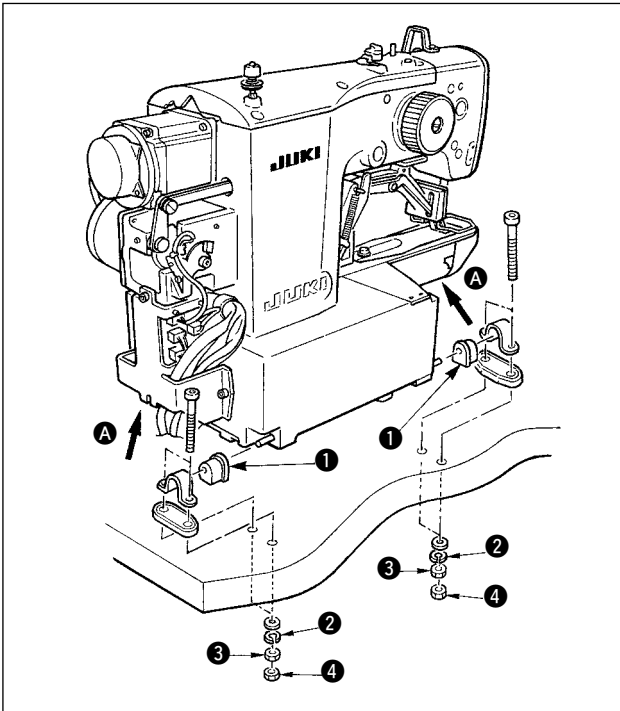

- 1) Fit hinge rubber ① to the hinge shaft ,and fix the sewing machine main unit.
- 2) When tightening nut ③ to hinge rubber ①, tighten nut ③ until spring washer ② becomes as B in the illustration, and fix it with nut ④.



If tightening hinge rubber ① excessively, it will not work properly. So, be careful.



Hold section A when moving the sewing machine.

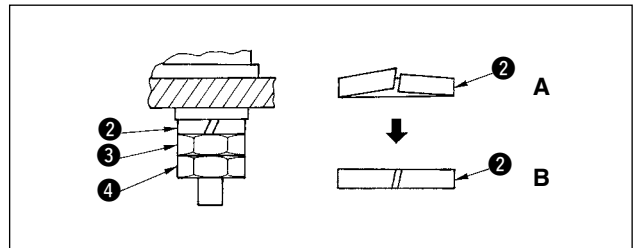

6. Installing the drain receiver and the head support rubber

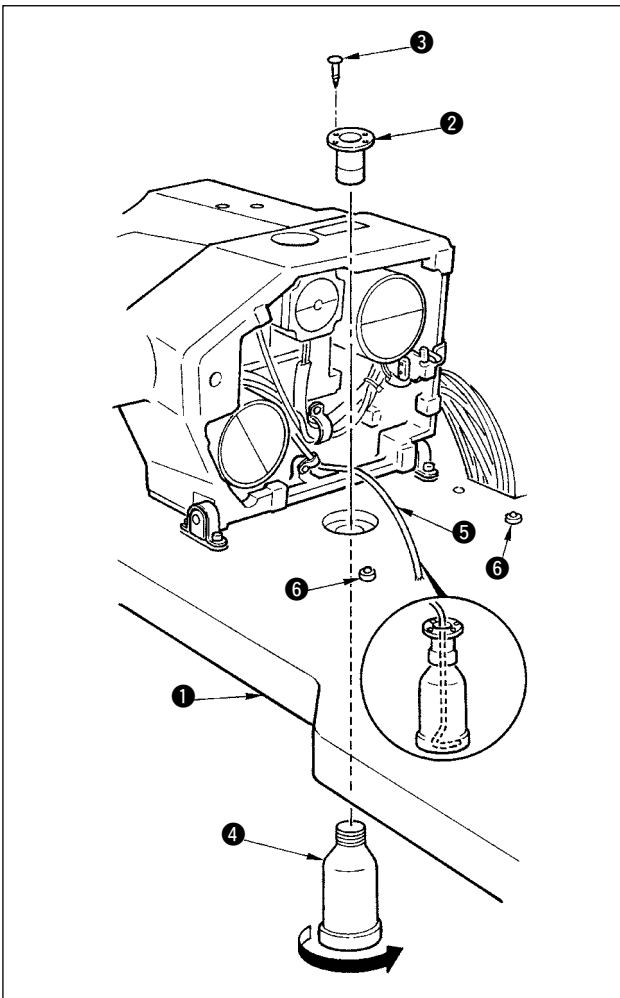

- 1) Fix drain receiver ② in the installing hole of table ① with two setscrews ③.
- 2) Screw in drain bin ④ to drain receiver ②.
- 3) Insert sewing machine drain pipe ⑤ into drain bin ④.
- 4) Insert head support rubber ⑥ into table ①.



1. Insert drain pipe ⑤ until it will go no further so that it does not come off drain bin ④ when tilting the machine head.

2. Remove the tape fixing drain pipe ⑤.

7. Safety switch

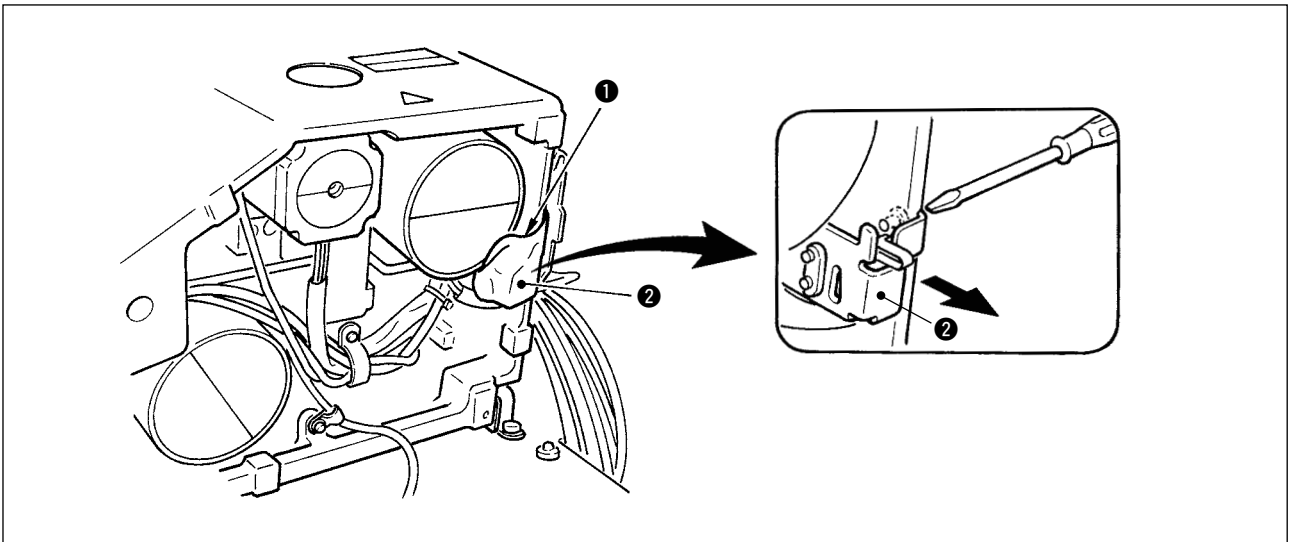

Remove tape ❶ fixing the lever section of safety switch ❷.



1. When using the safety switch without removing tape ❶, it is very dangerous since the sewing machine works even in the state that it is tilted.
2. In case error 302 occurs when the sewing machine works after setup, loosen the safety switch fitting screw with a screwdriver, and lower the switch to the downside of the sewing machine.

8. Tilting the sewing machine head



WARNING :

Tilt/raise the sewing machine head with both hands taking care not to allow your fingers to be caught in the head. Turn OFF the power before starting the work so as to prevent accidents caused by abrupt start of the sewing machine.

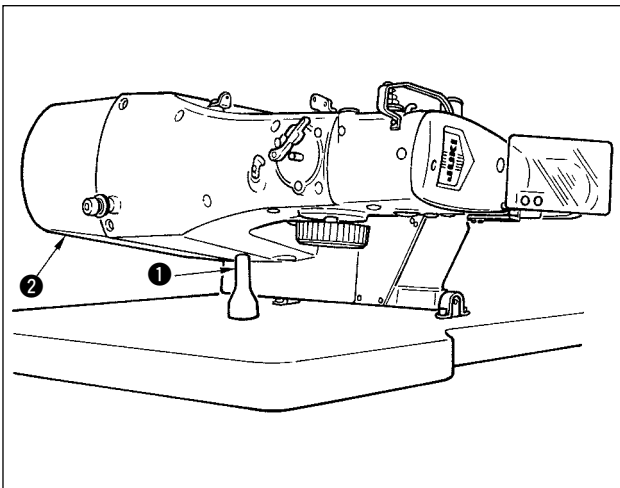

When tilting the sewing machine head, tilt the head gently until it comes in contact with head support rod

❶.

1. Before tilting the sewing machine head, make sure that head support rod ❶ is attached to the machine table.
2. When raising the sewing machine head, do not raise it while holding motor cover ❷. It will be the cause of breakage of motor cover ❷.
3. Be sure to tilt the sewing machine head on a flat place to prevent it from falling.



9. Installing the operation panel

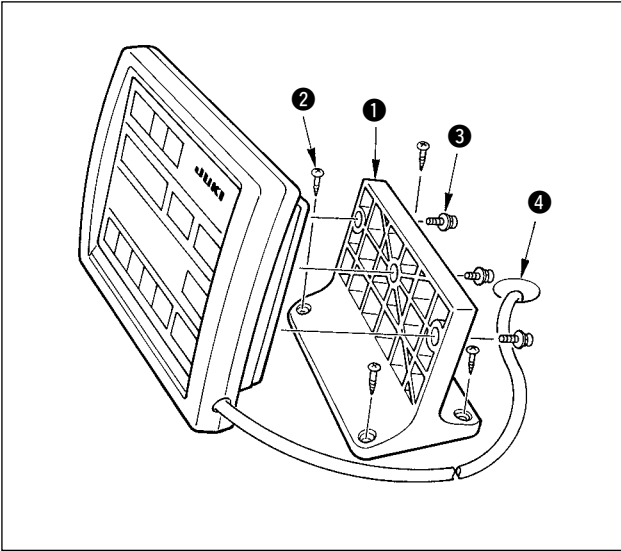

Fix operation panel installing plate **1** on the machine table with wood screws **2** and pass the cable through hole **4** in the machine table.

Fix the operation panel on panel installing plate **1** with screws **3** supplied as accessories.

Fix the cable on the bottom surface of the table with the staples supplied with the machine as accessories.

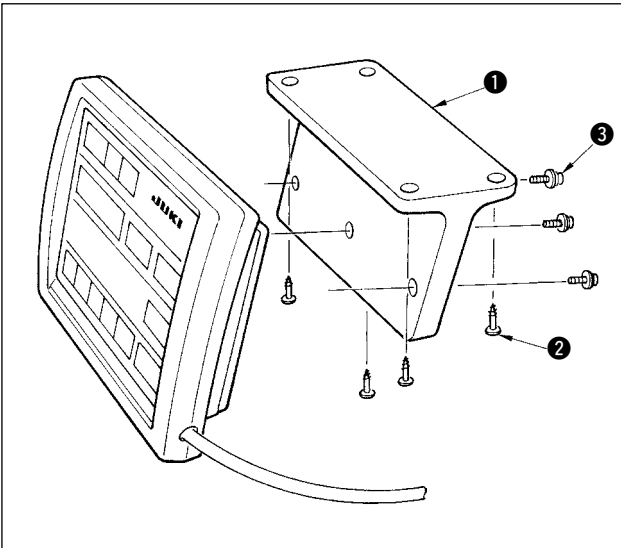

Refer to the figure on the left side when installing the panel under the table.

10. Connecting the cord

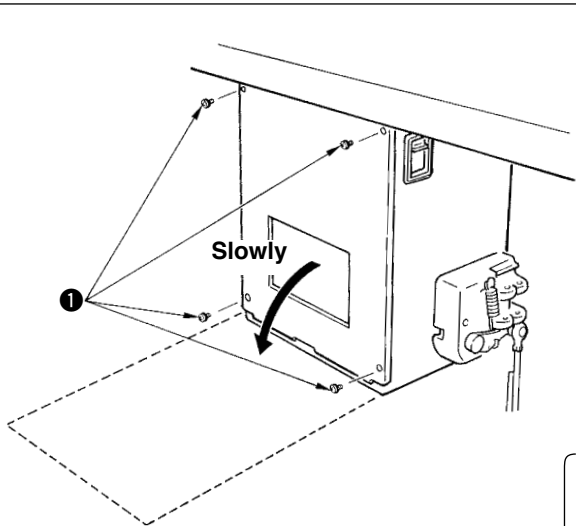

Remove four screws E fixing the rear cover of the electrical box. When opening the rear cover, pressing it with your hands, slowly open it by approximately 90° until it stops as illustrated.



Be sure to lend your hand to the rear cover in order not to let the rear cover fall. In addition, do not apply force to the rear cover opened.

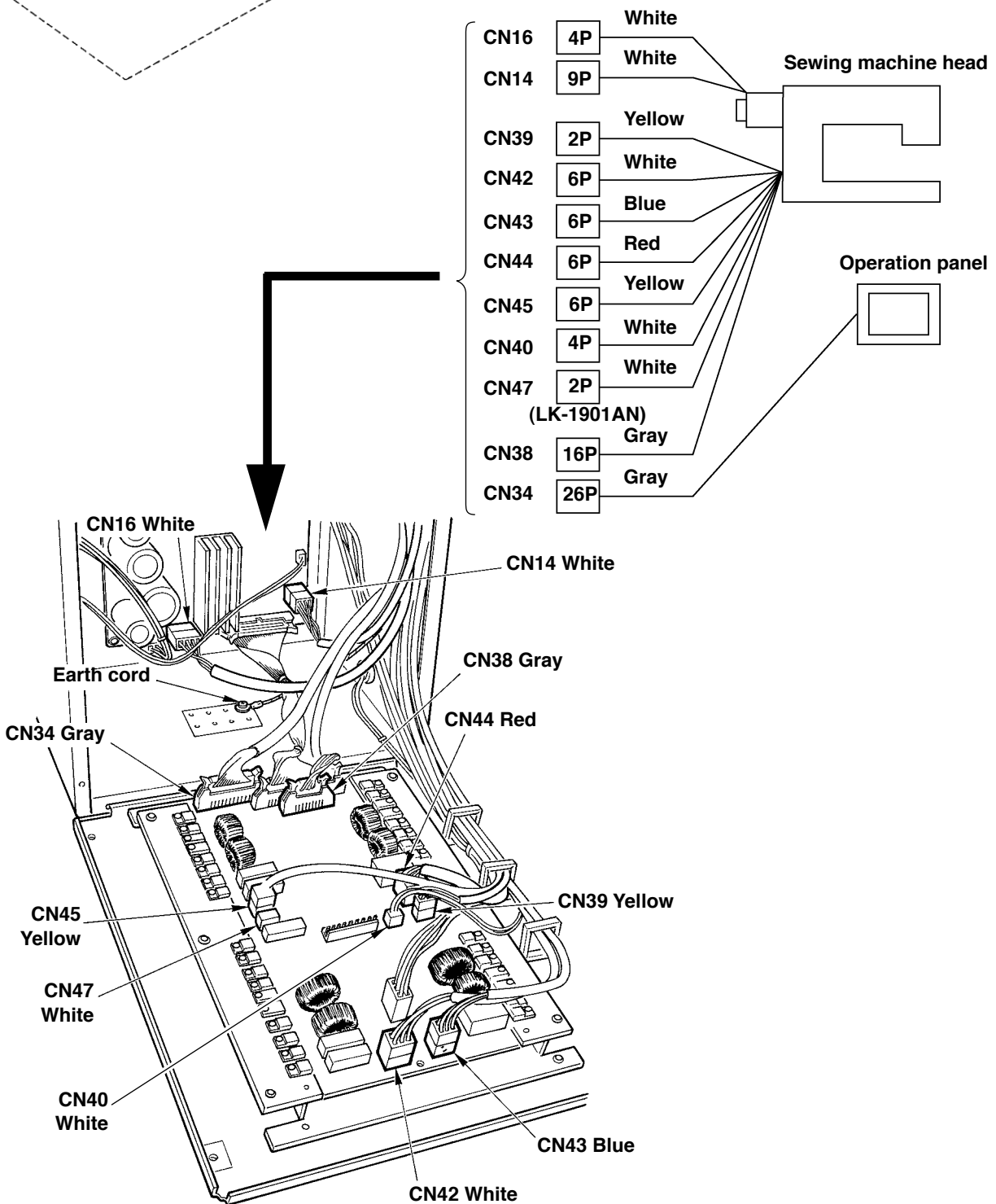

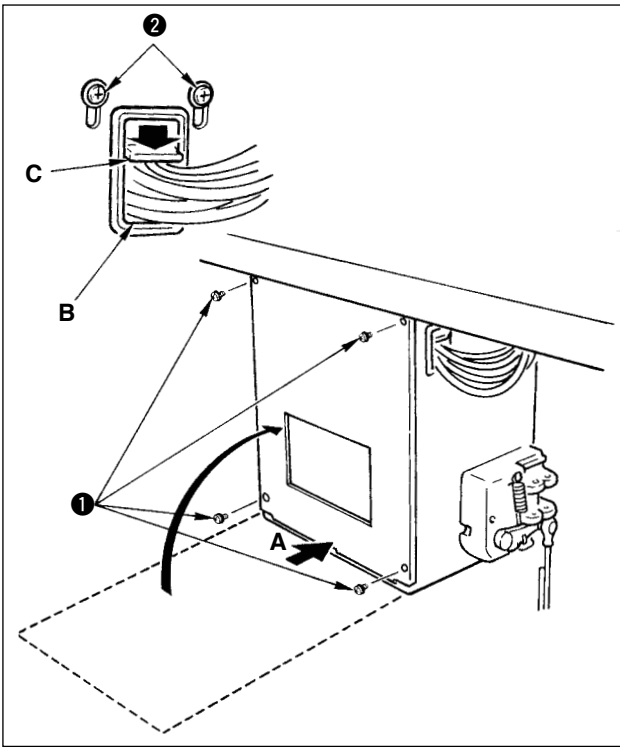

- 1) Take care so that the cord is not caught between the rear cover and the electrical box main body, close the rear cover while pressing section A on the lower side of the rear cover, and tighten four screws ❶.
- 2) Lower downward the cord located on the side of the control box and cord presser plate C in the push hole B, press the cord and tighten screws ❷.

How to lock the cord clamp

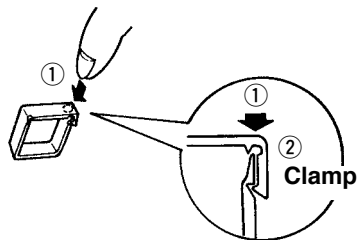

- ❶ Lightly press the corner of clamp.
(Cord clamp is locked with a click.)

How to remove the cord clamp

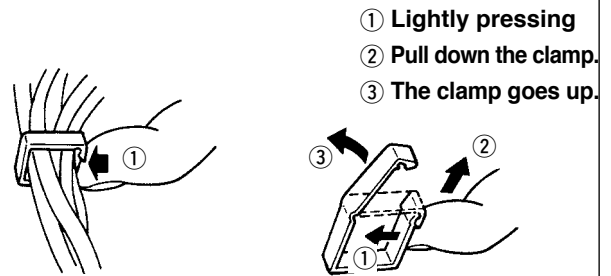

11. Installing the motor cover

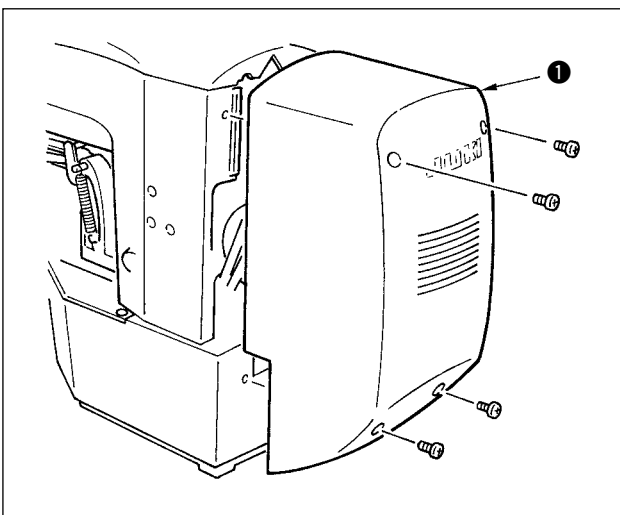

Install motor cover ❶ on the machine main unit with screws supplied with the machine as accessories.

12. Managing the cord

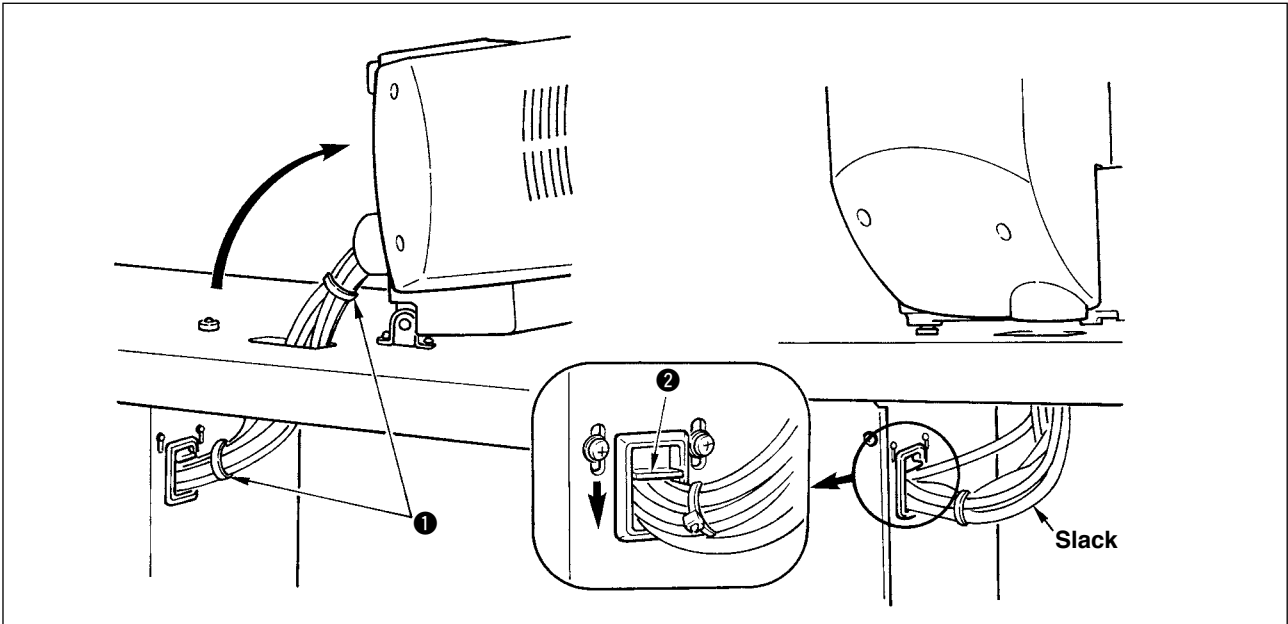

- 1) In the state that the sewing machine is tilted, connect the cords, and bundle them with clip band **1** as shown in the figure.
- 2) Fix the cords with cords setting plate **2** in the state that the cords slacken as shown in the figure.



When you tilt the sewing machine, make sure that the sewing machine head support bar is placed on the table.

13. Installing the eye protection cover



WARNING :

Be sure to attach this cover to protect the eyes from the disperse of needle breakage.

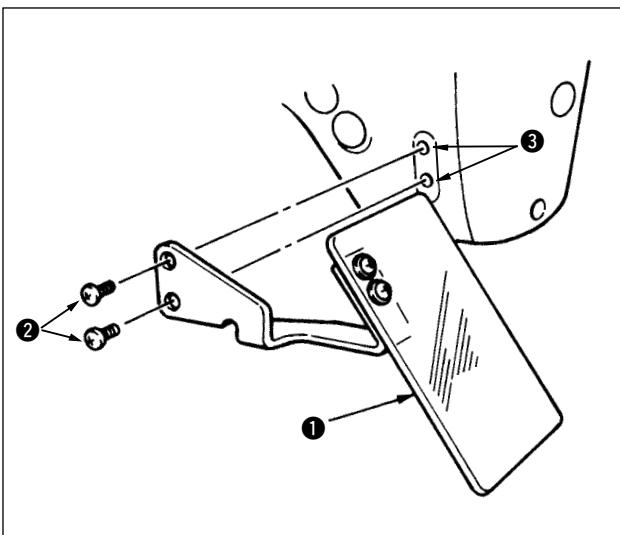

Be sure to use eye protection cover **1** after installing it on installing section **3** with screws **2**.

14. Installing the thread stand

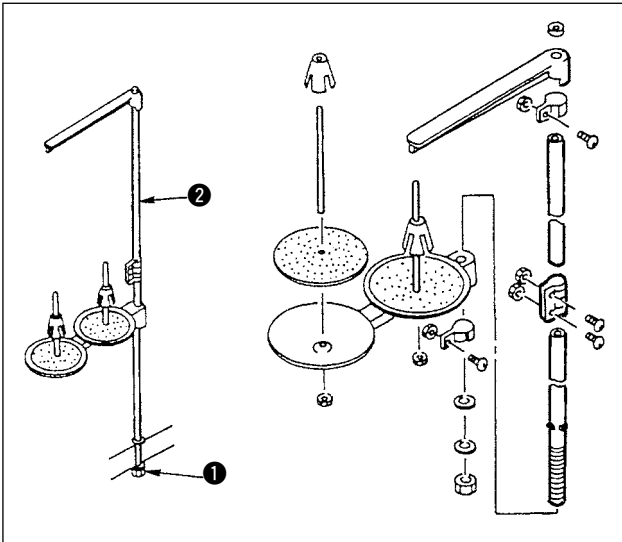

- 1) Assemble the thread stand unit, and insert it in the hole in the machine table.
- 2) Tighten locknut ❶ to fix the thread stand.
- 3) For ceiling wiring, pass the power cord through spool rest rod ❷.

[4] OPERATION OF THE SEWING MACHINE

1. Lubrication



WARNING :

Turn OFF the power before starting the work so as to prevent accidents caused by abrupt start of the sewing machine.

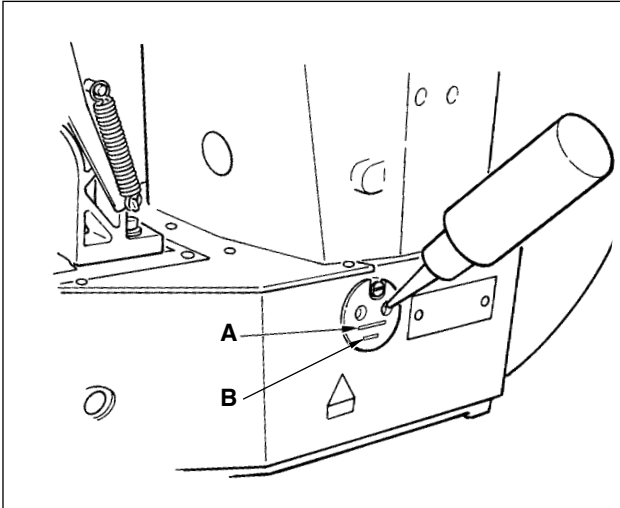

Check that the place between lower line B and upper line A is filled with oil. Fill there with oil using the oiler supplied with the machine as accessories when oil is short.

* The oil tank which is filled with oil is only for lubricating to the hook portion. It is possible to reduce the oil amount when the number of rotation used is low and the oil amount in the hook portion is excessive. (Refer to " I.[7]-8. Amount of oil supplied to the hook" p.35.)

1. Do not lubricate to the places other than the oil tank and the hook of Caution 2 below. Trouble of components will be caused.

2. When using the sewing machine for the first time or after an extended period of disuse, use the machine after lubricating a small amount of oil to the hook portion. (Refer to " I.[7]-2. Adjusting the needle-to-shuttle relation" p.32.)



2. Attaching the needle



WARNING :

Turn OFF the power before starting the work so as to prevent accidents caused by abrupt start of the sewing machine.

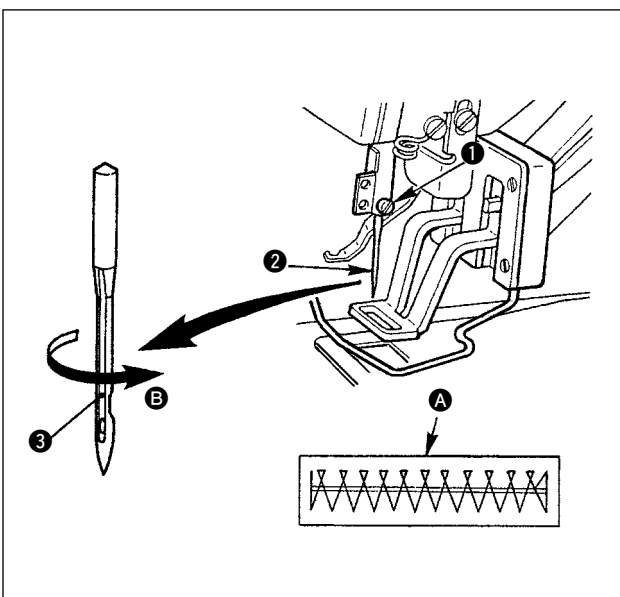

Loosen setscrew ① and hold needle ② with the long groove ③ facing toward you. Then fully insert it into the hole in the needle bar, and tighten setscrew ①.

If the stitches are made as shown in A, attach the needle facing to the direction A to a small extent.



3. Threading the machine head



WARNING :

Turn OFF the power before starting the work so as to prevent accidents caused by abrupt start of the sewing machine.

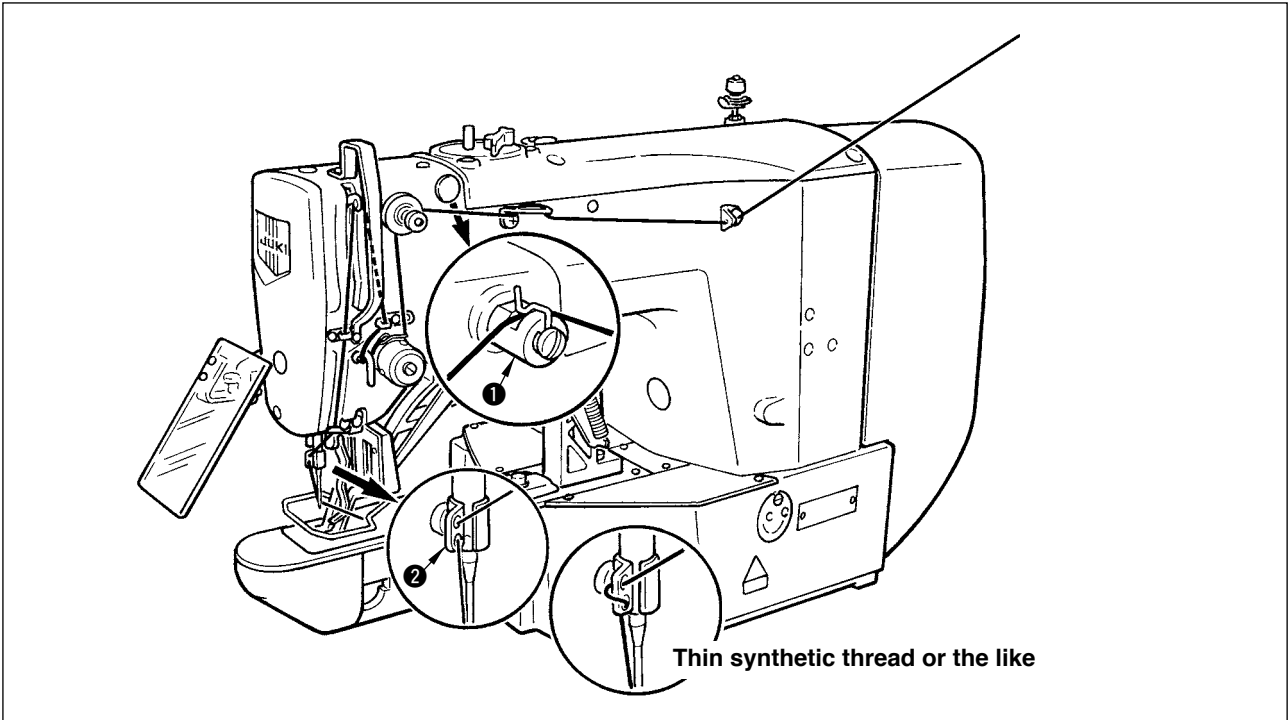

Pull out the thread by approximately 40mm from the needle after threading through the needle.



1. When the silicon oil is used, thread through thread guide for silicon ① (Optional)

2. For thick thread, pass the thread through one hole only of needle bar thread guide ②.

4. Installing and removing the bobbin case



WARNING :

Turn OFF the power before starting the work so as to prevent accidents caused by abrupt start of the sewing machine.

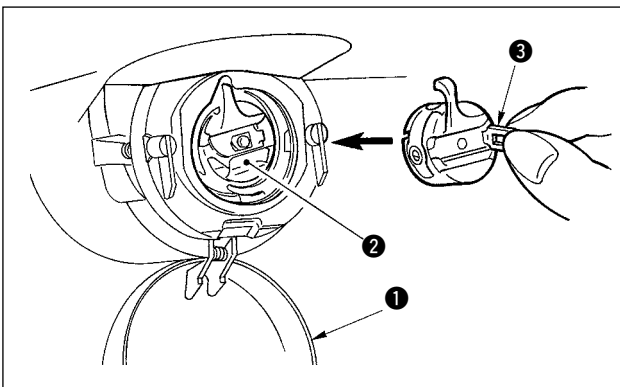

1) Open hook cover ①.

2) Raise latch ③ of bobbin case ②, and remove the bobbin case.

3) When installing the bobbin case, fully insert it into the shuttle shaft, and close the latch.



If it is not fully inserted, bobbin case ② may slip off during sewing.

5. Installing the bobbin



WARNING :

Turn OFF the power before starting the work so as to prevent accidents caused by abrupt start of the sewing machine.

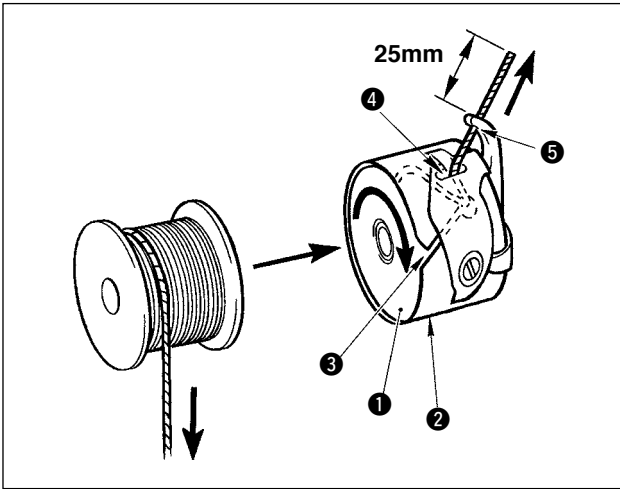

- 1) Set the bobbin ① into bobbin case ② in the direction shown in the figure.
- 2) Pass the thread through thread slit ③ of bobbin case ②, and pull the thread as it is. By so doing, the thread will pass under the tension spring and be pulled out from thread hole ④.
- 3) Pass the thread through thread hole ⑤ of the horn section, and pull out the thread by 25mm from the thread hole.

If the bobbin is installed in the bobbin case orienting the reverse direction, the bobbin thread pulling out will result in an inconsistent state.



6. Adjusting the thread tension

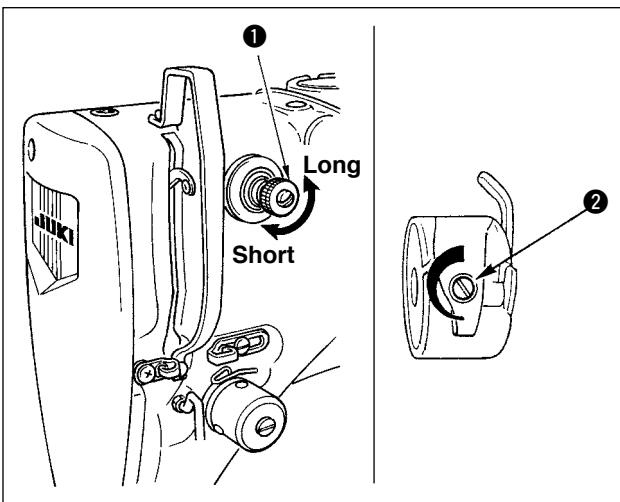



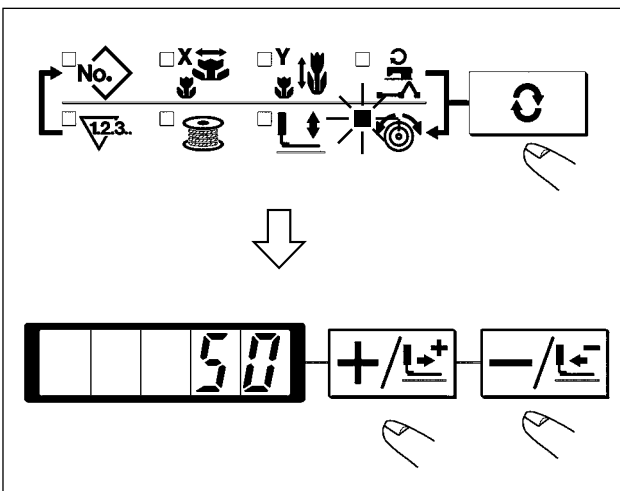

If thread tension controller No. 1 ① is turned clockwise, the length of remaining thread on the needle after thread trimming will be shorter. If it is turned counterclockwise, the length will be longer. Shorten the length to an extent that the thread is not slipped off.

Adjust needle thread tension from the operation panel and bobbin thread tension with ②.

Adjusting the needle thread tension



- 1) Select thread tension  with  key.
- 2) Set needle thread tension with  key or  key. There is a setting range of 0 to 200. When the set value is increased, the tension becomes higher.
 - * The tension is set so that 1.5 N (spun thread #50) is obtained at the set value 50 at the time of standard delivery. (When thread tension No. 1 is released.)

7. Adjusting the thread take-up spring

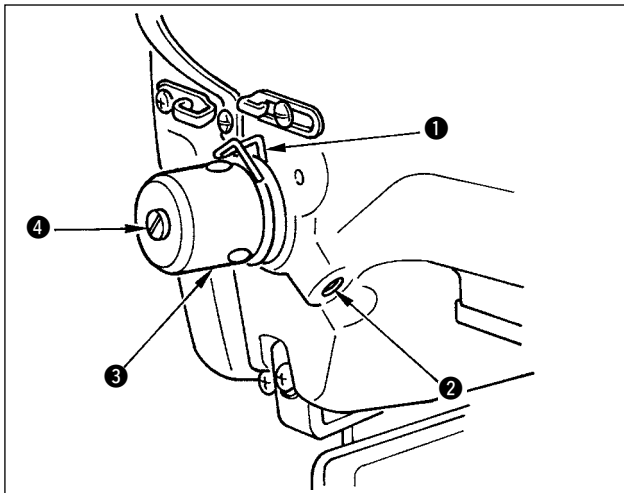

The standard stroke of thread take-up spring ① is 8 to 10 mm, and the pressure at the start is 0.1 to 0.3N.

1) Adjusting the stroke

Loosen setscrew ②, and turn thread tension asm.

③.

Turning it clockwise will increase the moving amount and the thread drawing amount will increase.

2) Adjusting the pressure

To change the pressure of the thread take-up spring, insert a thin screwdriver into the slot of thread tension post ④ while screw ② is tightened, and turn it. Turning it clockwise will increase the pressure of the thread take-up spring. Turning it counterclockwise will decrease the pressure.

8. Example of the thread tension

When using the sewing machine for the first time, adjust the thread tension referring to the table below.

Thread	Material	Needle thread tension setting	Thread take-up spring moving amount [Thread drawing amount]	Strength
Polyester filament thread #50	Wool	30 to 35	10mm [13mm]	0.1N
Polyester spun thread #50	Wool	50 to 55	10mm [13mm]	0.2N
Polyester spun thread #60 (Thread clamp OFF)	T/C broad	30 to 35	8 to 10mm [11 to 13mm]	0.1N
Cotton thread #50	Denim	35 to 45	10mm [13mm]	0.1N
Cotton thread #20	Denim	35 to 45	8 to 10mm [11 to 13mm]	0.1N

[5] OPERATION OF THE SEWING MACHINE (BASIC)

1. Item data setting

Set each item following the procedure described below.

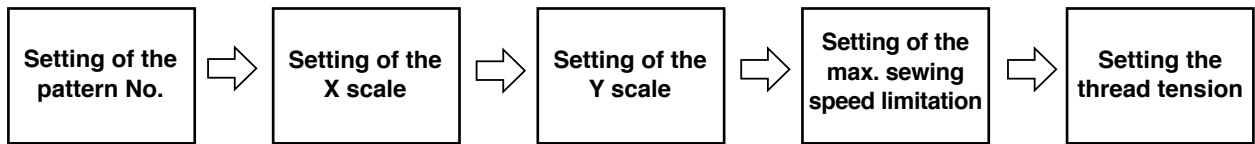

(1) Turn ON the power switch.

Pattern No. of the item selection lights up, and the pattern No. is indicated on the data display.

(2) Setting of the pattern No.

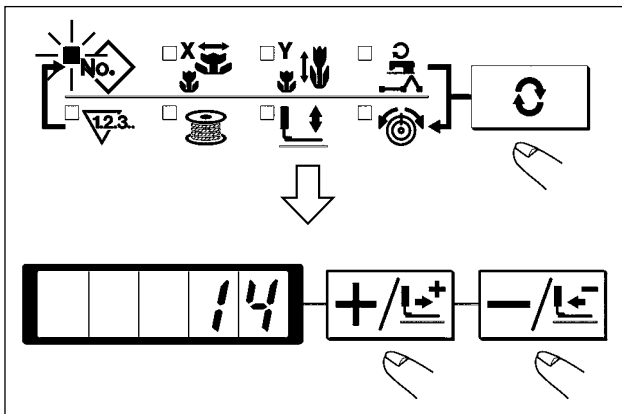

- 1) Press the key to indicate the item "Pattern NO" .
- 2) Press the or key to indicate "14" on the display. (Pattern No. is set to 14.)

Caution Refer the pattern No. to the separate table.

(3) Setting of the X scale

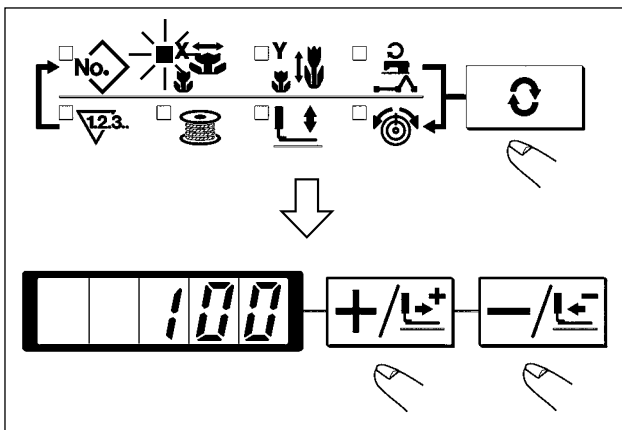

- 1) Press the key to indicate the item "X Scale" .
- 2) Press the or key to indicate "100". (Set X scale to 100%.)

Caution The setting exceeding 100% is dangerous since needle and the cloth presser interferes with each other and needle breakage or the like will occur.

(4) Setting of the Y scale

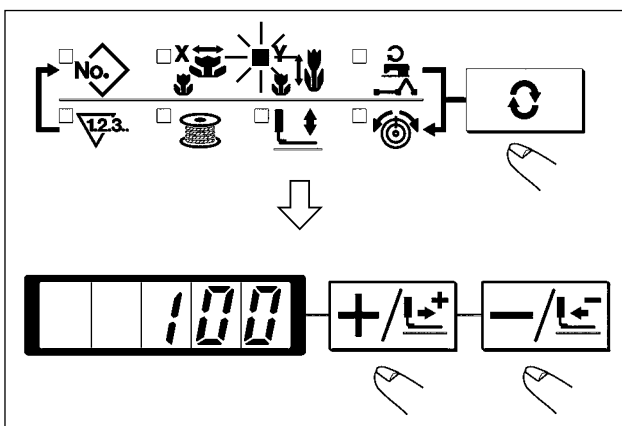

- 1) Press the key to indicate the item "Y Scale" .
- 2) Press the or key to indicate "100". (Set Y scale to 100%.)

Caution The setting exceeding 100% is dangerous since needle and the cloth presser interferes with each other and needle breakage or the like will occur.

(5) Setting of the max. sewing speed limitation

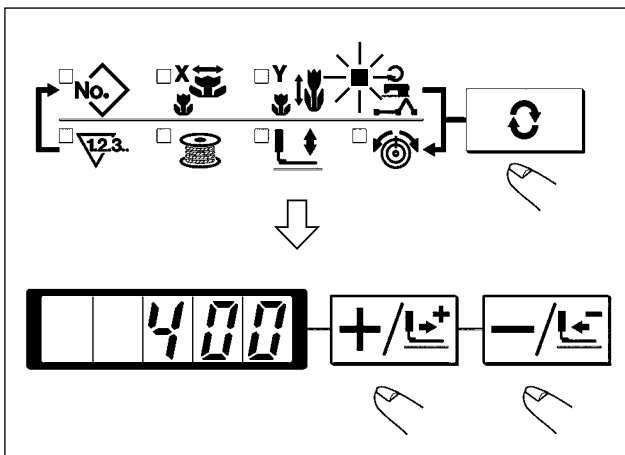

- 1) Press the key to indicate the item "Speed" .
- 2) Press or key to indicate "400". (Setting of 400 sti/min)

(6) Setting the thread tension

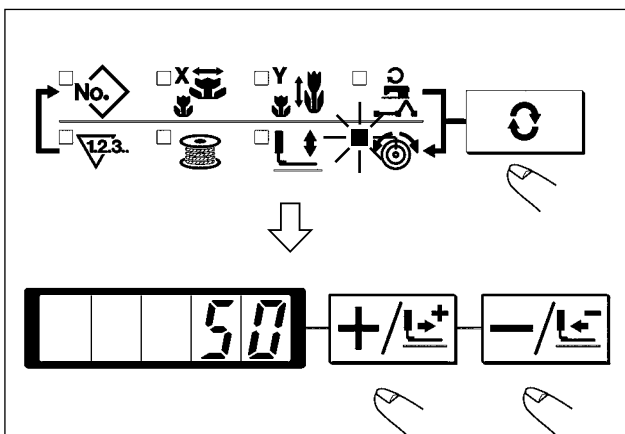

- 1) Press key to indicate the item "THREAD TENSION" .
- 2) Press or key to indicate "50". (0 to 200 can be set.)

(7) Finish of setting

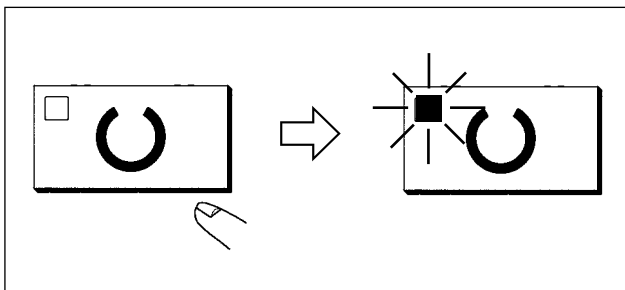

- 1) Press the key.
- 2) After the work clamp feet have moved and gone up, the sewing LED lights up, and the sewing is ready.

Caution When the presser is raised, be careful that fingers are not caught in the presser since the presser moves after having lowered.

- * When key is pressed, the set values of pattern No., X/Y scale, etc. are memorized.
- * If key is pressed, you can make sure of the respective setting items again. However, the items can not be changed in the state that the SEWING LED is lit up.
- * When key is pressed, the READY LED goes off. Set values of the respective items can be changed.
- * Thread tension can be changed even when the sewing LED lights up. Thread tension can be memorized with the start switch as well.
- * Use the machine after confirming the pattern No. When key is pressed while pattern No. is indicated "0" (state at the time of delivery), error display E-10 appears. At this time, re-set the pattern No.

Important When turning OFF the power without pressing key, the set values of pattern No., X/Y scale, number of max. rotation, and thread tension are not memorized.



2. Checking the contour of a sewing pattern

WARNING :

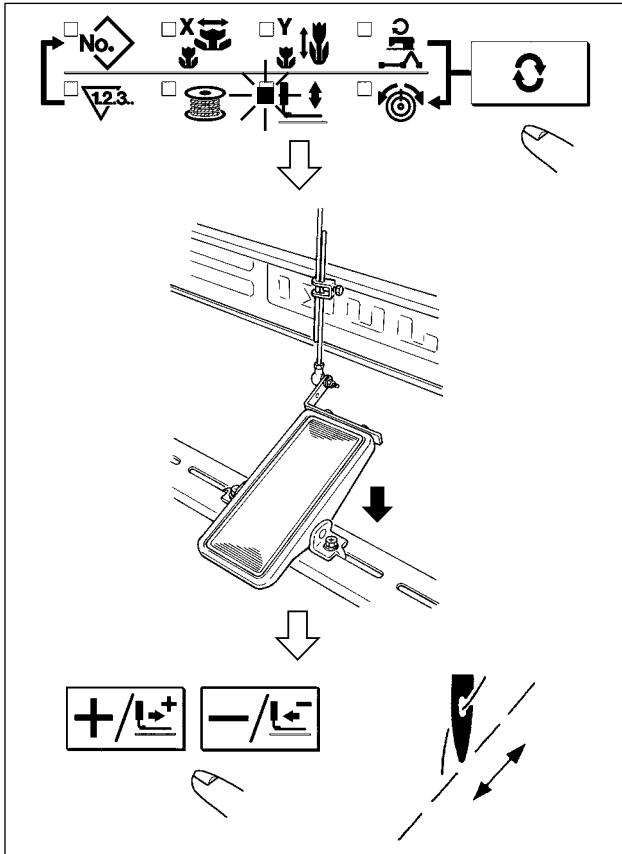

1. Make sure without fail of the contour of the sewing pattern after selection of the sewing pattern. If the sewing pattern extends outside the work clamp feet, the needle will interfere with the work clamp feet during sewing, causing dangerous troubles including needle breakage.
2. When making sure of the contour of the sewing pattern, press +/- key with the needle bar lowered, and the work clamp feet move after automatically making the needle bar return to the upper position.



- 1) Press  key to make the READY LED light up.
- 2) Select the work clamp foot lowering  with  key.
- 3) Lower the work clamp feet with the foot switch.



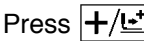

The sewing machine does not start even when the foot switch is depressed under this mode.

- 4) Press  key in the state that the work clamp feet are lowered.



The work clamp feet do not go up even when the foot switch is detached.

- 5) Confirm the contour of the pattern with  key or  key.
- 6) The work clamp feet will go up when  key is pressed.



The work clamp feet do not come down immediately after turning ON the power.

- (Caution) When using a sewing pattern which is full in lengthwise direction (+10 mm), make sure of the clearance between cloth feed base ② and wiper base ①. If there is no clearance, loosen setscrew ③ and move the wiper to the needle side. Especially when the needle position comes to the rear on the right side, the clearance is decreased.

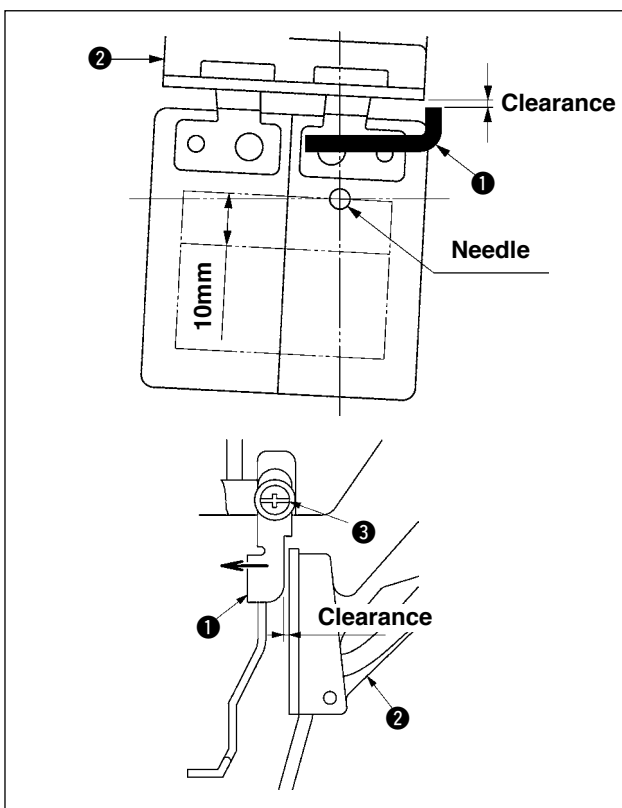



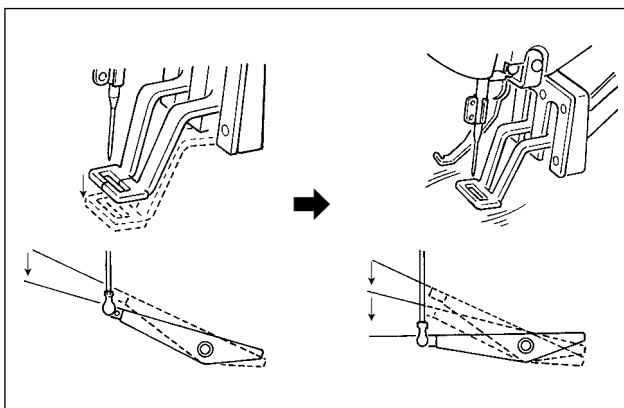



3. Sewing

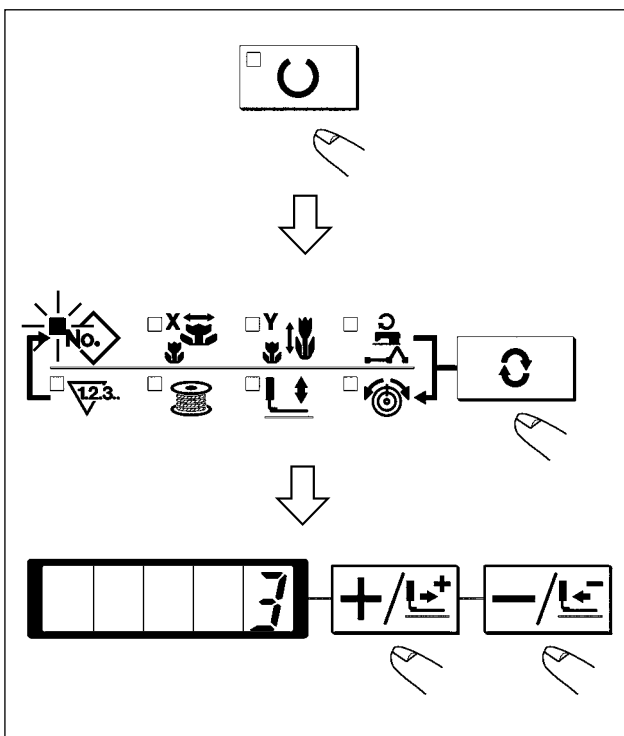

- 1) Set a workpiece on the work clamp foot section.
- 2) Depress the pedal switch to the first step, and the work clamp feet will come down. If you detach your foot from the pedal switch, the work clamp feet will go up.
- 3) Depress the pedal switch to the second step after descending the work clamp feet at the first step, and the sewing machine will start sewing.
- 4) After the sewing machine completes sewing, the work clamp feet will go up, and return to the sewing start position.

4. Change to the other sewing pattern



- 1) Make the Sewing LED go off with  key.
- 2) Press  key and select the item of pattern No. .
- 3) Set the pattern No. with  key or  key
- 4) Similarly, setting of X/Y scale, speed, etc. is performed.
- 5) When  key is pressed, the Sewing LED lights up and the sewing machine is in the sewing ready state.



WARNING :

Make sure without fail of the contour of the sewing pattern after selection of the sewing pattern.

If the sewing pattern extends outside the work clamp feet, the needle will interfere with the work clamp feet during sewing, causing dangerous troubles including needle breakage.

5. Winding a bobbin

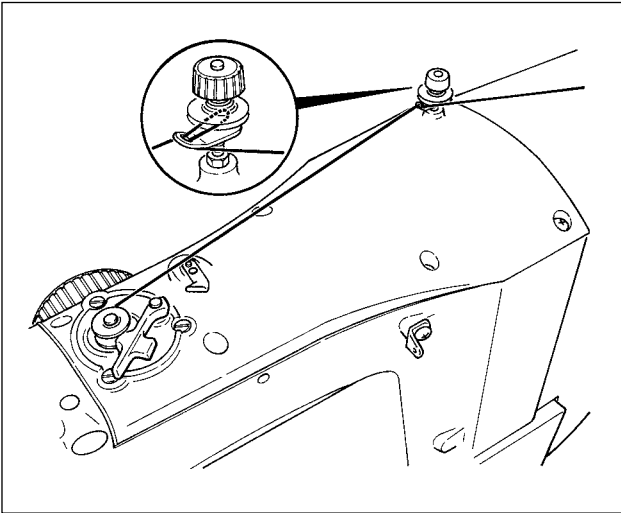

5-1. To wind a bobbin while the sewing machine is performing sewing





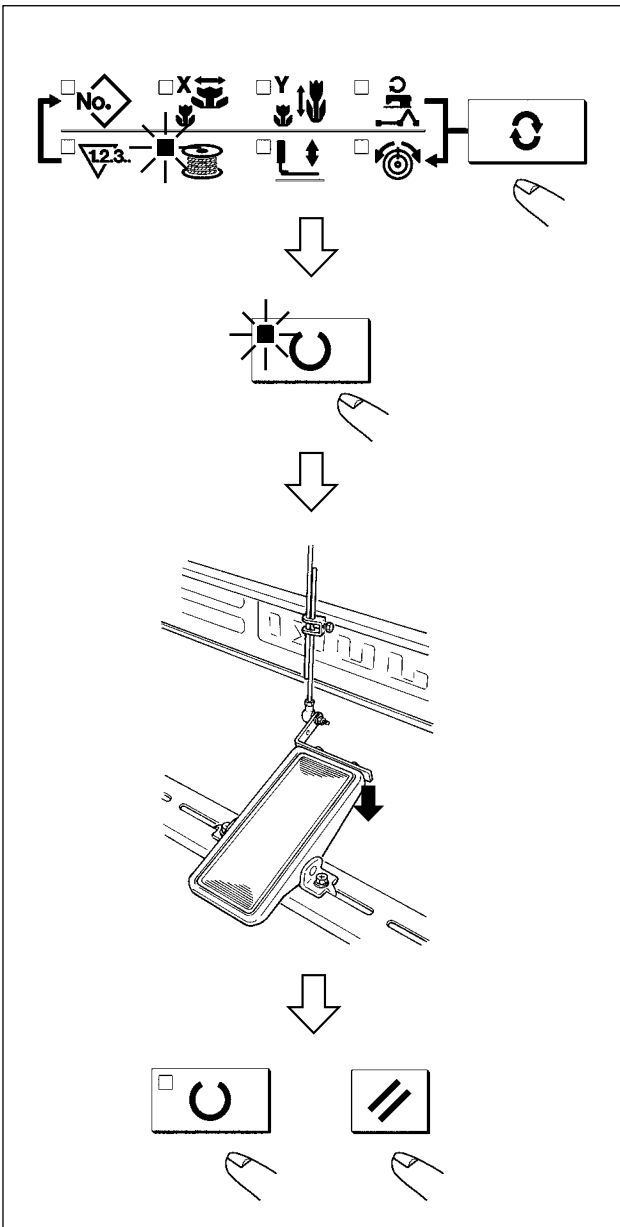

Thread the bobbin winder and wind the bobbin thread onto the bobbin as illustrated in the figure.

5-2. To wind a bobbin independently



- 1) Press  key to make the SEWING LED go off.
- 2) Select the bobbin winder  with  key.

Caution Selection cannot be performed when the Sewing LED is lit up.

- 3) Press  key. The work clamp feet come down and the Sewing LED lights up.
- 4) When the pedal switch is depressed, the sewing machine rotates.
- 5) When the pedal is depressed again, or  key or  key is pressed, the sewing machine stops.
- 6) When  key is pressed, the Sewing LED goes off, the work clamp feet go up and  key becomes effective.

Caution Bobbin winder does not work immediately after turning ON the power. Perform the bobbin winding after setting pattern No. or the like once, pressing the  key, and making the sewing LED light up.

6. Thread clamp device

Trouble of sewing (slip-off of needle thread, stitch skipping, or stain of needle thread) at the time of high-speed start can be prevented with the thread clamp device. The thread clamp device works in the state that the thread clamp indication LED lights up and does not work when the LED goes off. Changeover of ON/OFF motion is performed with  key. When the thread clamp device is OFF, the start automatically becomes the slow start.



1. When memory switch No. 35 is "1" (prohibited), the thread clamp does not work. In addition,  key is ineffective.
2. Memory switch, refer to " I.[8] HOW TO USE THE MEMORY SWITCH" p.38.

* Matters that demand special attention when using the needle thread clamp device

(1) In case of with the needle thread clamp (motion), make shorter the length of needle thread remaining on the needle at the sewing start for use. When the length of needle thread is lengthened, needle thread on the wrong side of material is apt to protrude. In addition, when the length is excessively lengthened, the end of needle thread held by the needle thread clamp may be rolled in the seams.

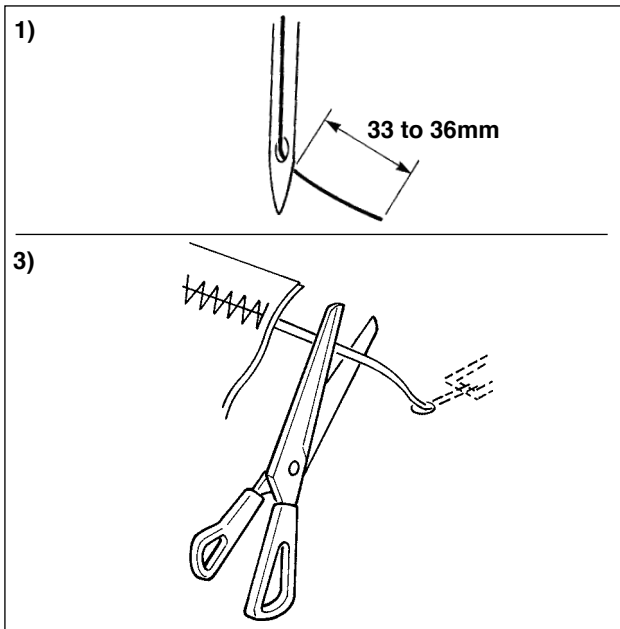

- 1) In case of with the needle thread clamp, the standard of the length of needle thread is 33 to 36 mm.
- 2) When needle thread is long after replacing thread or the like or sewing while holding needle thread by hand, turn OFF the THREAD CLAMP  key.
- 3) When the needle thread held with the thread clamp is rolled in the seams, do not draw the material forcibly and cut the connecting needle thread with the scissors or the like. The seams are not damaged since it is the needle thread at the sewing start.

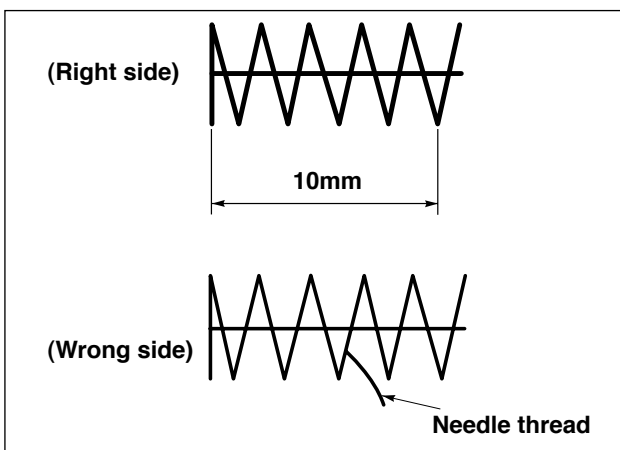

(2) It is possible to adjust needle thread shorter by making the needle thread clamp work while holding the stabilized sewing at the start of sewing and the gathering (bird's nest) of needle thread on the wrong side of material can be lessened. However, for the pattern which the stitch length for neatly rolling in needle thread is short, needle thread may protrude from the wrong side of material. Select with/without thread clamp referring to the item below.

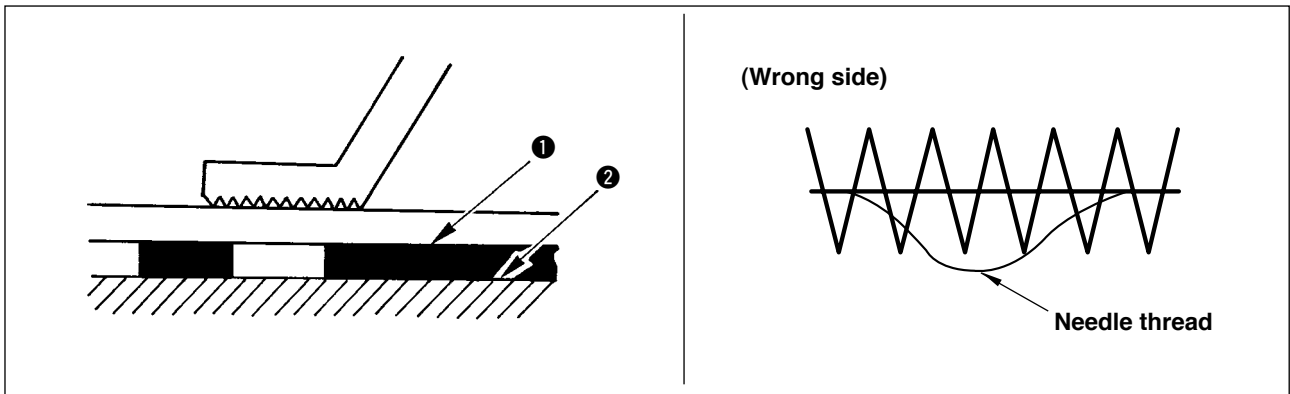

- 1) When the sewing length is short (less than approximately 10 mm), the end of needle thread may protrude like beard even when adjusting needle thread shorter.

(3) When the type of lower plate ❶ that material does not come in close contact with throat plate ❷ is used, needle thread on the wrong side of material may be rolled in the seams regardless of needle thread play or sewing length.



(4) For LK-1903AN (button sewing), the thread clamp is set to the motion prohibited in the state of standard delivery due to the aforementioned (2) and (3). For (memory switch No. 35) with cross-over stitch ( , etc.) or X shape ( , etc.), needle thread on the wrong side of material becomes easy to be rolled in. In this case, it is recommended to use the thread clamp.

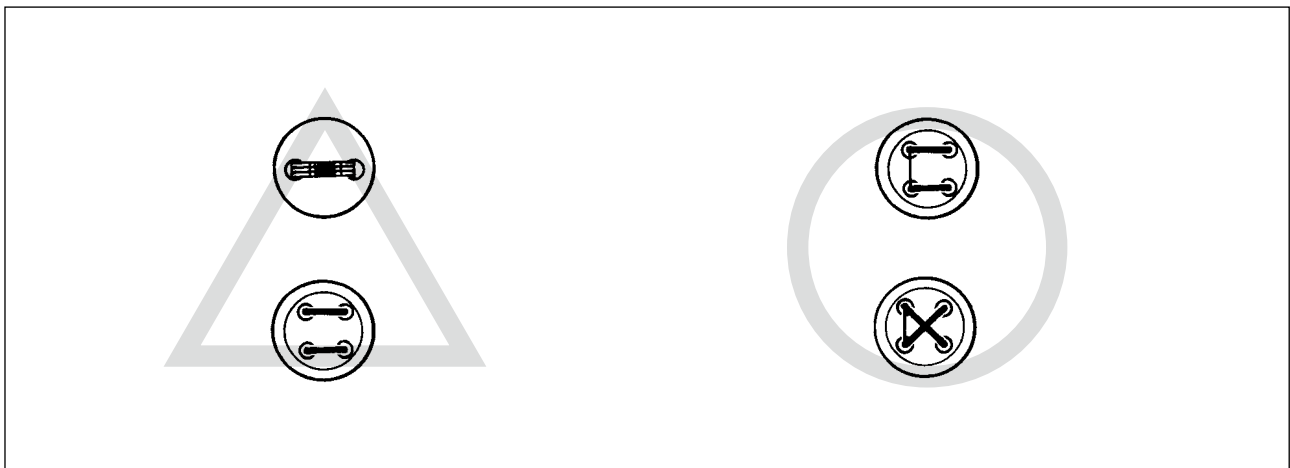

(5) When the thread clamp is used, and bobbin thread at the sewing start appears on the right side of material, reduce thread tension at the sewing start (2 to 3 stitches) and bobbin thread becomes less conspicuous.





[Example of setting] Tension of 1 to 2 stitches at the sewing start is “20” when sewing tension setting is “35”.

* For the setting of tension at the sewing start, refer to " I . [6]-5. Setting the pattern thread tension" p.30.

[6] OPERATION OF THE SEWING MACHINE (ADVANCED)

1. Performing sewing using the pattern keys (, , , and)















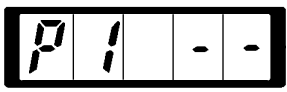

Patterns (No.1 to 200) which have been already registered can be registered to P1 to P50. It is possible to change and register the scale, max. speed limitation, thread tension and sewing position. Same as the patterns (No.1 to 200), P1 to P50 are used by the selection by scrolling the pattern Nos. The pattern calling from P1 to P25 can be made by one-touch as well.

* When selecting P6 to P25, perform the selection by combination (simultaneous pressing) of , , ,  and  keys as shown in the table below.

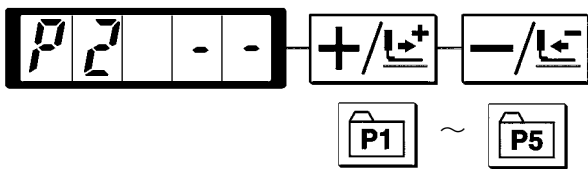
P-No.	Selection key	P-No.	Selection key	P-No.	Selection key	P-No.	Selection key
P1	P1	P8	P1+P4	P15	P4+P5	P22	P2+P3+P4
P2	P2	P9	P1+P5	P16	P1+P2+P3	P23	P2+P3+P5
P3	P3	P10	P2+P3	P17	P1+P2+P4	P24	P2+P4+P5
P4	P4	P11	P2+P4	P18	P1+P2+P5	P25	P3+P4+P5
P5	P5	P12	P2+P5	P19	P1+P3+P4		
P6	P1+P2	P13	P3+P4	P20	P1+P3+P5		
P7	P1+P3	P14	P3+P5	P21	P1+P4+P5		

(1) Register to the pattern key

Setting example : Register following setting to the P2., Pattern No. 3, X scale rate : 50%, Y Scale rate : 80%, Max. speed limitation : 2,000 sti/min, Thread tension : "50", Pattern position : 0.5 mm to the right and 1 mm to the front

- 1) Turn ON the power switch and press  key to enter mode setting (memory switch setting). (Sewing LED should be put out.) 
- 2) Indicate the pattern register mode with  or  key. 
- 3) Press  key.
Enter the pattern register mode. 
- 4) Press  key. (Select P-No. to be registered.)
Selection can be performed with  or  key. 
- 5) Press  key to indicate the Pattern No. 
Set the Pattern No. to "3" with  or  key. 

6) Press key and set as follows with or key.
 X Scale rate : “50”%, Y Scale rate : “80”
 %, Max. speed limitation : “2000” sti/min,
 Thread tension : “50”

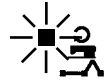
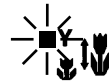
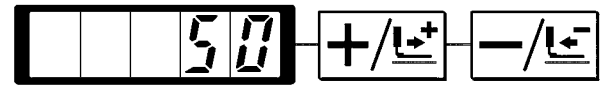

7) Press key and “X Scale rate ” indication becomes 0.0. Traveling amount in X direction can be set in 0.1 mm unit. Set 0.5 with or key.

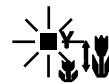

8) Press key and “Y Scale rate ” indication becomes 0.0. Traveling amount in Y direction can be set in 0.1 mm unit. Set -1.0 with or key.



9) Press key to finalize the setting.

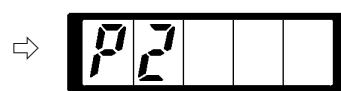

10) Press key.
 Pattern register mode is finalized.

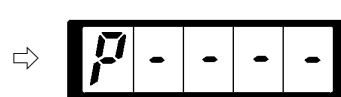

11) Press key.
 Mode setting is finalized and the mode returns to the normal mode.

(2) Sewing operation

Operation example : After performing sewing with the contents of the registered P2, perform sewing with the contents of P3.

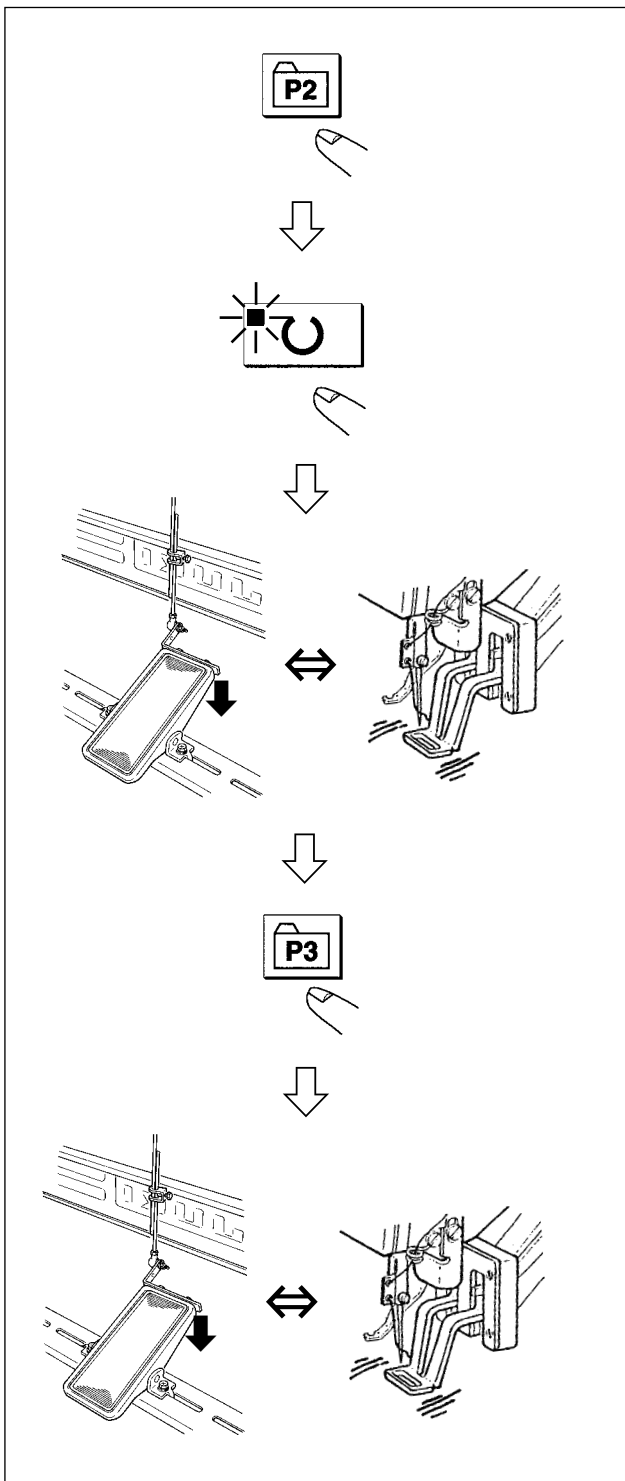

- 1) Turn ON the power switch.
- 2) Press the **P2** key.
- 3) Press the **U** key, and when the sewing LED lights up, the work clamp foot goes up after it has moved.
- 4) Check the contour of the sewing pattern.
(Refer to the item " I.[5]-2. Checking the contour of a sewing pattern" p.19.)
- 5) If the contour of the sewing pattern is acceptable, the sewing can be made.
- 6) Press **P3** key after completion of sewing and the presser comes down. The presser moves to the sewing start point after origin retrieval and goes up. (The P keys can operate the pattern change by one-touch even when the sewing LED is lighting up.)
- 7) Perform the above items 4) and 5).

* The P1 to P25 can be indicated on the display when selecting the pattern by pressing the **+ / P** or **- / P** key.

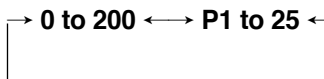

P1 to P25 which have not been registered are not indicated.

Press P1 to P25 key while the sewing LED lights up and the presser comes down. Be careful that your fingers are not caught in the presser.

Pattern register from P26 to P50 can be performed. Register can not be performed in **P1 to **P5** key. Designate the pattern by the pattern selection only. Indicate the pattern with **+ / P** or **- / P** key.**

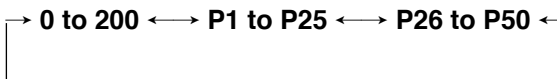







Pattern selection from P26 to P50 cannot be performed while the sewing LED lights up.

2. Performing sewing using the combination function

By arranging in the order of use of the pattern register (P1 to P50) which have been already registered and registering in C1 to C20, the sewing pattern will change in the order every time the sewing machine finishes the sewing. Every one combination No. can be registered up to the maximum 30 patterns.

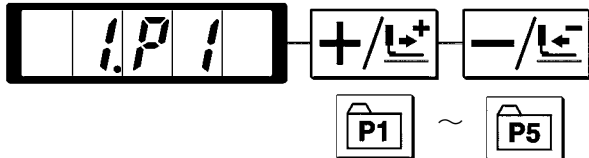
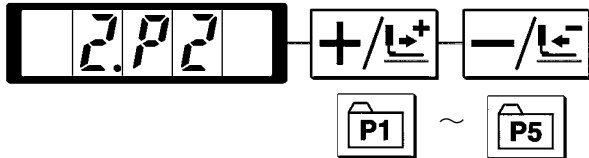
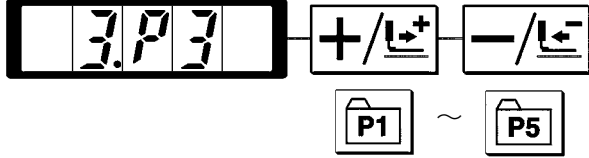
(1) Register of the combination

Setting example : Combine in the order of P1, P2 and P3, and register them in the C1.

- 1) Turn ON the power switch and press **M** key to enter the mode setting (memory switch setting). (Sewing LED should be put out.) ⇒ 
- 2) Indicate the combination mode with **+ / ←** or **- / →** key. ⇒ 
- 3) Press **□** key. Sewing LED lights up to enter the combination mode. C1 to C20 can be selected with **+ / ←** or **- / →** key. ⇒ 
- 4) Press **⏪** key, and then press **P1** key. P1 is set to the first pattern of C1. P1 to P50 can be selected with **+ / ←** or **- / →** key as well. ⇒ 
- 5) Press **⏪** key, and then press **P2** key. P2 is set to the second pattern of C1. P1 to P50 can be selected with **+ / ←** or **- / →** key as well. ⇒ 
- 6) Press **⏪** key, and then press **P3** key. P3 is set to the third pattern of C1. P1 to P50 can be selected with **+ / ←** or **- / →** key as well. ⇒ 
- 7) Press **□** key to finalize the register. ⇒ 
- 8) Press **M** key. Combination register mode is finalized. ⇒ 
- 9) Press **M** key. Mode setting is finalized and the mode returns to the normal mode. ⇒ 

(2) Sewing operation

Operation example : Perform sewing with the contents of the registered C1.

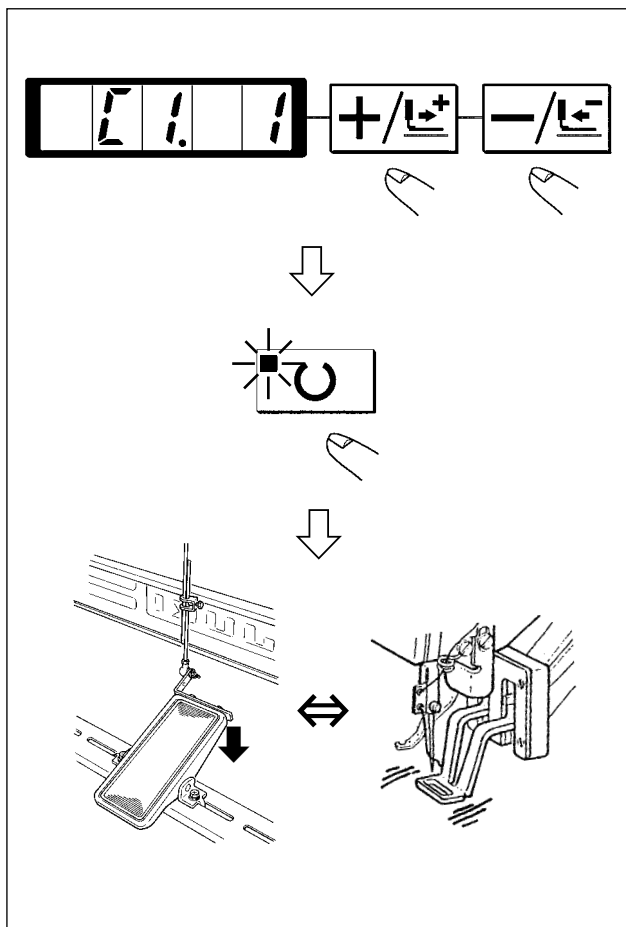

- 1) Turn ON the power switch.
- 2) Set the pattern No. to "C1-1 " using the **+/L+** or **-/L-** key. Scroll as follows :

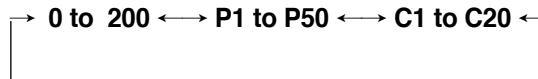

- 3) Press the **⏻** key. When the sewing LED lights up, the work clamp feet will go up after having moved.
- 4) If the contour of the pattern is acceptable, the sewing can be made.
- 5) Every time the sewing is finished, the step is made in the order of the combination. After completing one cycle of sewing, the step returns to the first step. The sewing can be made repeatedly.

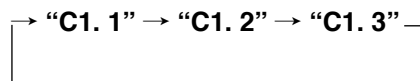

- * When you desire to return the pattern to the previous one or skip the next pattern after sewing, press **+/L+** or **-/L-** key in a state that the sewing LED lights up. The indication of the pattern will change, and the work clamp feet will move to the sewing start point.
- * If the contents of P1 to P50 are changed after registration of C1 to C20, the contents of P1 to P50 used in C1 to C20 will change. So, be careful.
- * Make sure of the contour of the pattern for each of the patterns. (Refer to the item "[I .\[5\]-2. Checking the contour of a sewing pattern](#)" p.19.)

3. Performing sewing using the “bobbin thread counter”

The production counter can be used as the bobbin thread counter. In case a same sewing pattern is sewn in repetition, the sewing machine will stop sewing when the number of times (the specified number) that can be sewn with a bobbin is reached. The bobbin thread counter is of the subtracting method.



The counter at the time of delivery is set to the production counter (adding method).

If it is used as the bobbin thread counter, it is necessary to change over memory switch No. 18. (Refer to the item " I .[8] HOW TO USE THE MEMORY SWITCH" p. 38.)

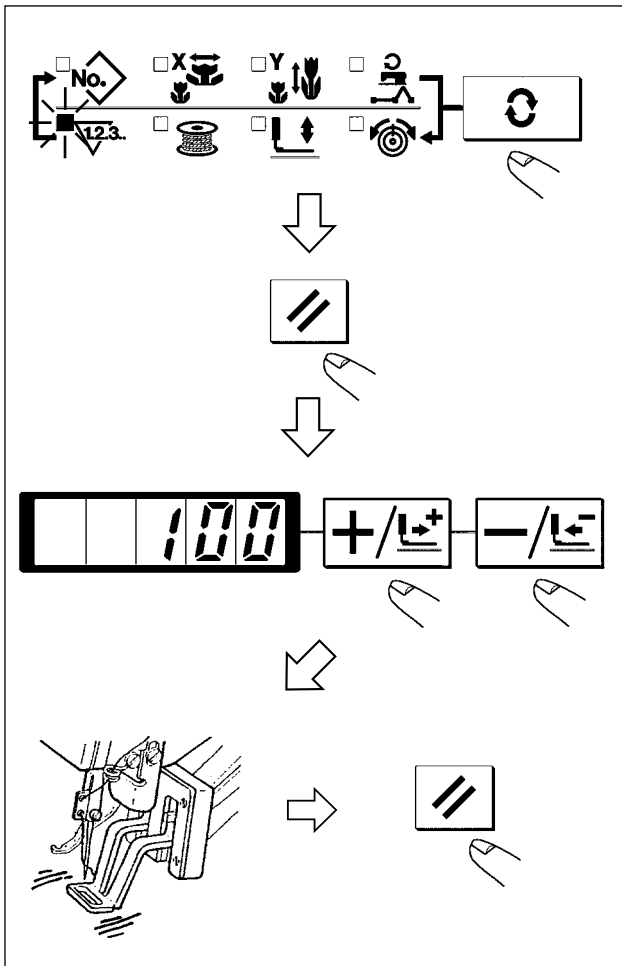

- 1) Press key to indicate the Counter .
- 2) Then press the key.
- 3) Then press the or key, and set the specified number of times that can be sewn with a bobbin.
- 4) Every time the sewing machine finishes a sewing cycle, counting-down is made by one.
- 5) When the sewing machine finishes the specified number of times, the sewing machine does not start even if depressing the pedal.
- 6) Replace the bobbin with a new one, and press the key. The value of the counter returns to the set value.
- 7) Repeat the steps of procedure from the steps 4) to 6).

4. How to use the temporary stop

When memory switch No. 31 is set to "1", key can be used as the temporary stop key. (Refer to " I .[8] HOW TO USE THE MEMORY SWITCH" p.38.)

- 1) Sewing machine stops by means of key. Error 50 is indicated, the error release is performed using key.



- 2) There are three operations after the release as below.

- ① Re-start of sewing by means of the start switch.
- ② Press key to perform thread trimming, perform positioning with or key, and re-start by means of the start switch.
- ③ Press key to perform thread trimming, and press again key to return to the origin.

5. Setting the pattern thread tension

Needle thread tension for 6 stitches at the sewing start, the portion which is changed over from basting stitch to zigzag stitch, and the portion of tie stitch at the sewing end can be individually set.

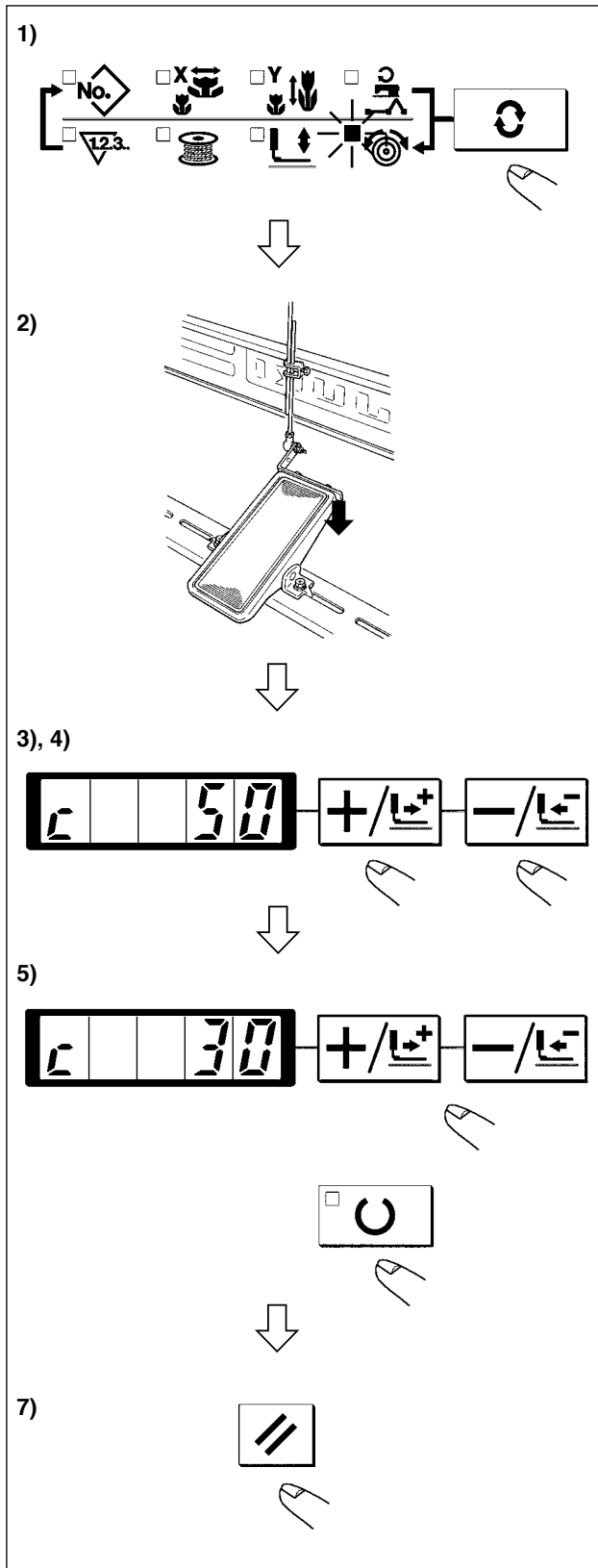

- 1) While the sewing LED lights up, press key to indicate the needle thread tension .
- 2) Lower the presser with the foot pedal.

Caution When the foot pedal is depressed until it will go no further, the sewing machine starts. So, be careful.

- 3) Move the feed with key.
- 4) "c" is indicated at the position where the tension setting is possible.
- 5) Pressing key, set the tension with or key.
- 6) Repeat steps 3), 4) and 5) to set the tension.
- 7) When setting is completed, press key. The presser moves to the origin and goes up.

6. Cautions in operation

- (1) When the error indicator lamp lights up, be sure to check the cause of trouble and take a proper corrective measure.
- (2) Do not draw, by hand, the material being sewn during sewing. Doing so will cause the needle shift from the correct position. If the needle moves from the correct position, press the  key two times. This will return the needle to the normal origin.
- (3) Do not turn OFF the power in a state that the needle is lowered. The presser comes down and the wiper interferes with needle. As a result, there is a danger of needle breakage or the like.

Reference for the sewing speed to be applied

Sewn product / thread / needle	Head type / Sewing speed
8-layered denim / Cotton thread #50 / DPx5 #16	S (Standard) / 3,200 sti/min
8-layered woolen gabardine / Polyester filament #50 / DPx5 #14	S (Standard) / 2,300 sti/min
8-layered denim / Cotton thread #20 / DPx17 #19	H (Heavy-weight material)/3,200 sti/min, W (Double-capacity hook)/2,700 sti/min
Overlapped sewing of 6 x 12-layered denim / Cotton thread #20 / DPx17 #19	H (Heavy-weight material) / 2,500 sti/min
Tricot + shoulder strap (3 + 1) layered section / Polyester spun #60 / DPx5 #11	F (Foundation) / 2,000 sti/min

- * To prevent the thread breakage due to the needle heat, set the sewing speed referring to the above table in accordance with the sewing conditions.
- * For sewing the foundation or the like, lower the height of the needle bar to prevent the stitch skipping. (Refer to the item "Adjusting the height of the needle bar")

[7] MAINTENANCE

1. Adjusting the height of the needle bar



WARNING :

Turn OFF the power before starting the work so as to prevent accidents caused by abrupt start of the sewing machine.

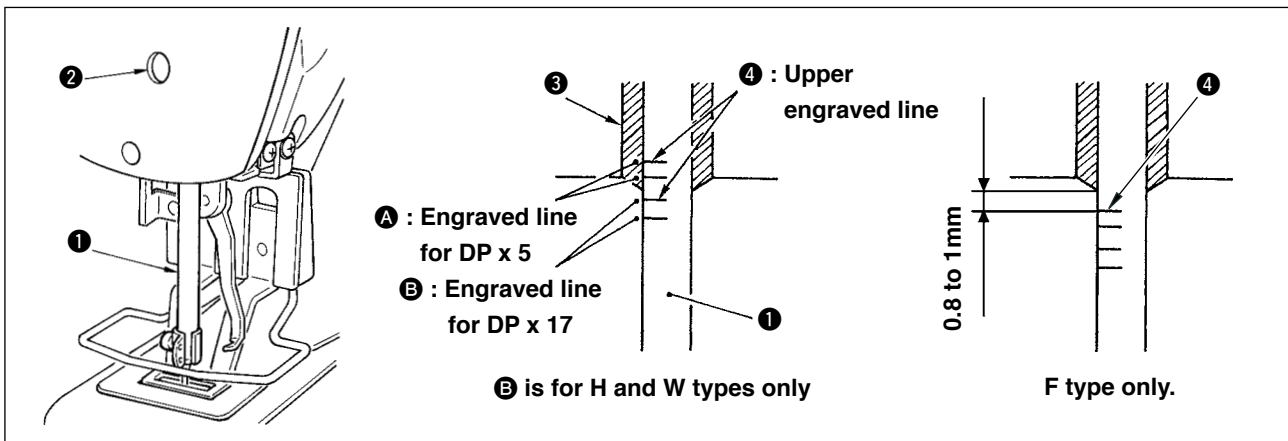

Bring needle bar ① to the lowest position of its stroke. Loosen needle bar connection screw ② and adjust so that upper marker line ④ engraved on the needle bar aligns with the bottom end of needle bar bushing, lower ③. For F type only, adjust the needle bar to the position where it is lowered by 0.8 mm to 1 mm from the center of upper marker line ④ engraved on the needle bar.



After the adjustment, make sure that there is no uneven torque.

- * When stitch skipping occurs in accordance with the sewing conditions, adjust the height of the needle bar so as to lower it by 0.5 to 1 mm from the needle bar engraved line ④.

2. Adjusting the needle-to-shuttle relation



WARNING :

Turn OFF the power before starting the work so as to prevent accidents caused by abrupt start of the sewing machine.

Relation between needle and engraved lines

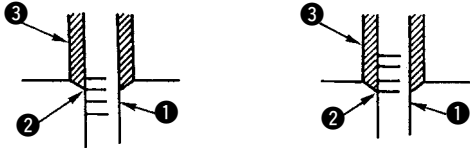

- 1) Turn the handwheel by hand. When needle bar **1** has gone up, adjust so that lower marker line **2** engraved on the needle bar aligns with the bottom end of the needle bar bushing **3**, lower.

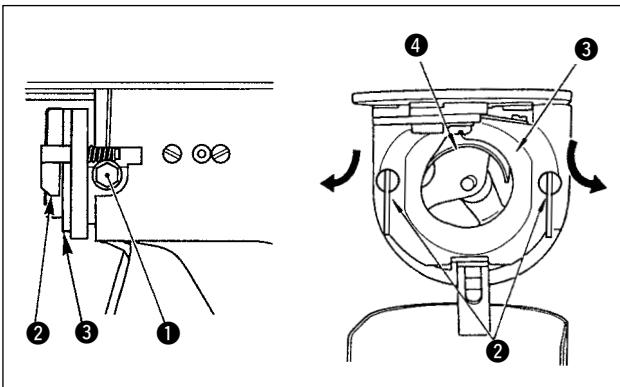

- 2) Loosen setscrew **1** in the driver. Open inner hook pressers **2** to the right and left, and remove inner hook presser **3**.



At this time, be careful not to let inner hook **4** come off and fall.

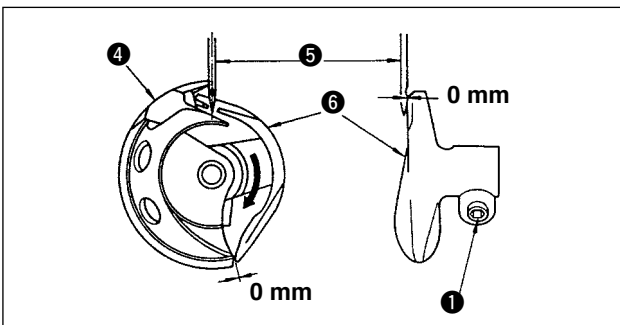

- 3) Adjust so that the blade point of inner hook **4** aligns with the center of needle **5**, and that a clearance of 0 mm is provided between the front end of the driver and the needle as the front end face of driver **6** receives the needle to prevent the needle from being bent. Then tighten setscrew **1** of the driver.

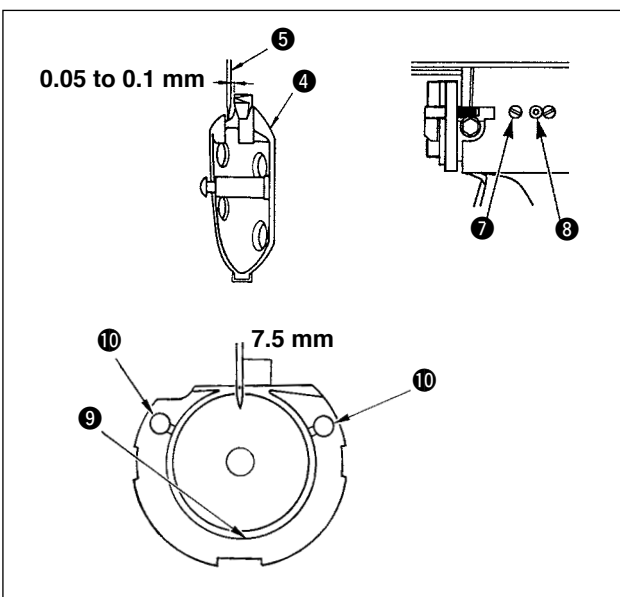

- 4) Loosen setscrew **7** of the shuttle, and adjust the longitudinal position of the shuttle. To do this adjustment, turn shuttle race adjusting shaft **8** clockwise or counterclockwise to provide a 0.05 to 0.1 mm clearance between needle **5** and the blade point of inner hook **4**.
- 5) After adjusting the longitudinal position of the shuttle, further adjust to provide a 7.5 mm clearance between the needle and the shuttle by adjusting the rotating direction. Then tighten setscrew **7** of the shuttle.



Apply a small amount of oil to race section **9** and oil wick **10**, and use the sewing machine after an extended period of disuse or cleaning the periphery of hook portion.

3. Adjusting the lift of the work clamp foot



WARNING :

As the work is performed while the power is ON, never touch the switches other than the necessary one so as to prevent accidents caused by the malfunction of switches.

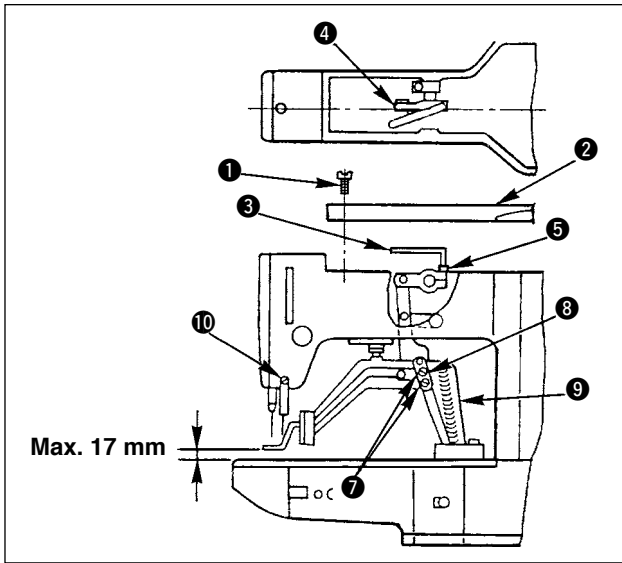

- 1) With the machine in stop mode, remove six set-screws ① of the top cover, and take off top cover ② .
- 2) Apply L-shaped wrench ③ to socket bolt ⑤ of clamp ④ , and loosen the socket bolt.
- 3) Push down L-shaped wrench ③ to increase the lift of the work clamp foot, or pull it up to decrease the lift.
- 4) After the adjustment, securely tighten socket bolt ⑤ .
- 5) If the right and left work clamp feet are not levelled, loosen fixing screw ⑦ and adjust the position of the work clamp foot lever support plate ⑧ to level them.



At this time, be careful not to cause work clamp foot lever support plate ⑧ to interfere with feed bracket ⑨ .

If the work clamp foot lever support plate interferes with the wiper, readjust the height of the wiper using setscrew ⑩ in the wiper installing base.

4. The moving knife and counter knife



WARNING :

Turn OFF the power before starting the work so as to prevent accidents caused by abrupt start of the sewing machine.

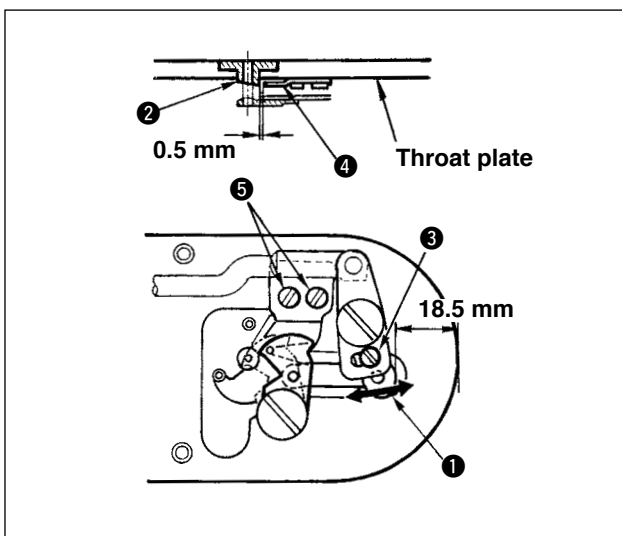

- 1) Loosen adjusting screw ③ so that a clearance of 18.5 mm is provided between the front end of the throat plate and the top end of thread trimmer lever, small ① . To adjust, move the moving knife in the direction of arrow.
- 2) Loosen setscrew ⑤ so that a clearance of 0.5 mm is provided between needle hole guide ② and counter knife ④ . To adjust, move the counter knife.

5. Needle thread clamp device



WARNING :

Turn OFF the power before starting the work so as to prevent accidents caused by abrupt start of the sewing machine.

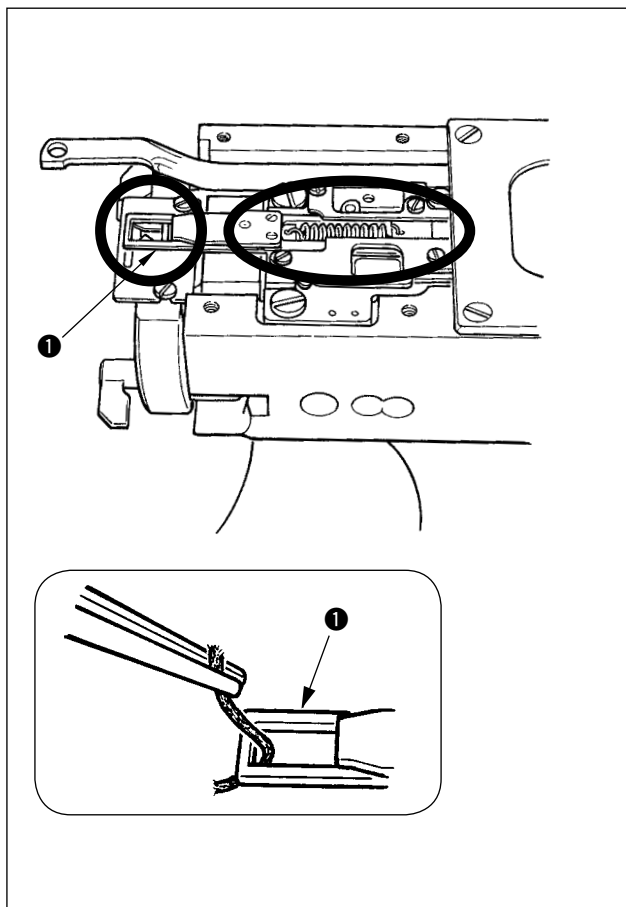

- 1) When thread is caught at top end ❶ of the thread clamp, thread clamp becomes incomplete and sewing trouble at the sewing start will be caused. Remove it with tweezers or the like.
- 2) When removing thread waste or thread dust collected on the thread clamp device, remove it after removing the throat plate.

6. Adjustment of the wiper



WARNING :

Turn OFF the power before starting the work so as to prevent accidents caused by abrupt start of the sewing machine.

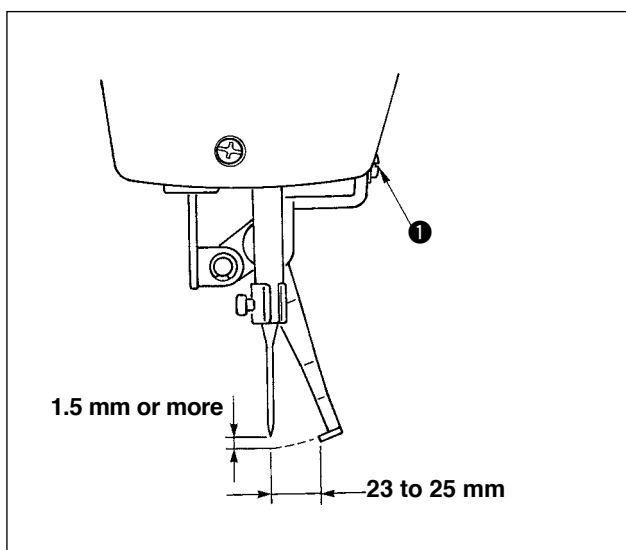

- 1) Loosen screw ❶ to adjust so that a clearance of 1.5 mm or more is provided between the wiper and the needle.
At this time, the standard of the distance between the wiper and the needle is 23 to 25 mm. By adjusting the distance wide, the work clamp foot can prevent stepping on needle thread when it comes down.
Especially when the thin needle is used, adjust the distance wide to such an extent of 23 mm.
- * The position of the needle is when the sewing machine has stopped after the sewing finished.

7. Draining waste oil

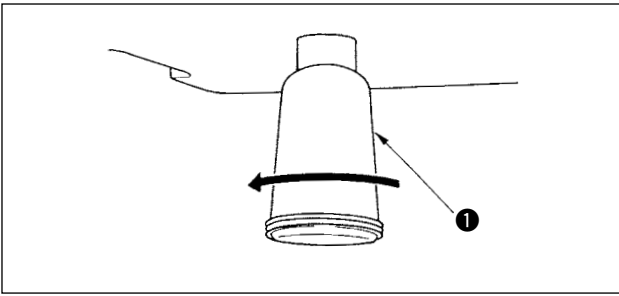

When polyethylene oiler ① becomes filled with oil, remove polyethylene oiler ① and drain the oil.

8. Amount of oil supplied to the hook

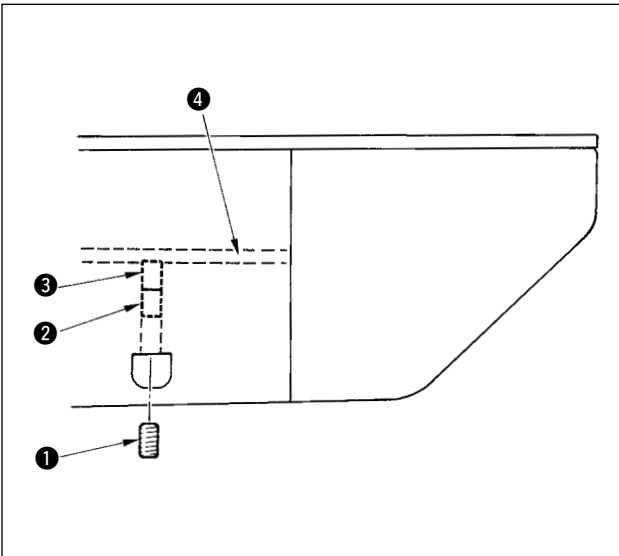

- 1) Loosen setscrew ① and remove setscrew ① .
- 2) When screwing in adjustment screw ② , the amount of oil of oil pipe, left ④ can be reduced.
- 3) After the adjustment, screw in setscrew ① and fix it.

1. The state of standard delivery is the position where ③ is lightly screwed in and returned by 4 turns.

2. When reducing the amount of oil, do not screw in the screw at once. Observe the state for approximately half a day at the position where ③ is screwed in and returned by 2 turns. If reducing is excessive, worn-out of the hook will result.



9. Replacing the fuse



DANGER :

1. To avoid electrical shock hazards, turn OFF the power and open the control box cover after about five minutes have passed.
2. Open the control box cover after turning OFF the power without fail. Then, replace with a new fuse with the specified capacity.

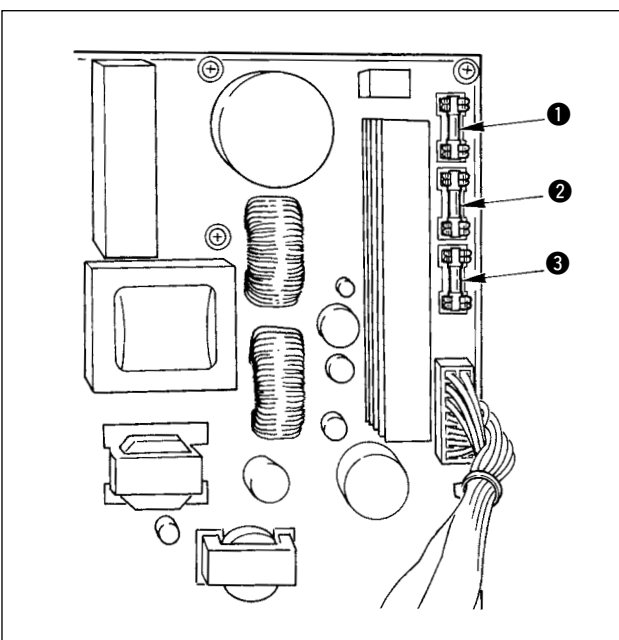

The machine uses the following three fuses :

- ① For pulse motor power supply protection
5A (time-lag fuse)
- ② For solenoid and pulse motor power supply protection
3.15A (time-lag fuse)
- ③ For control power supply protection
2A (fast-blow type fuse)

10. Changing the voltage of 100/200V



WARNING :

To prevent personal injuries caused by electric shock hazards or abrupt start of the sewing machine, carry out the work after turning OFF the power switch and a lapse of 5 minutes or more. To prevent accidents caused by unaccustomed work or electric shock, request the electric expert or engineer of our dealers when adjusting the electrical components.

It is adaptable to the voltage of single phase 100V to 120V/3-phase 200V to 240V by changing the voltage changeover connector mounted on FLT p.c.b.

(Caution) When the changing procedure is wrong, the control box will be broken. So, be very careful.

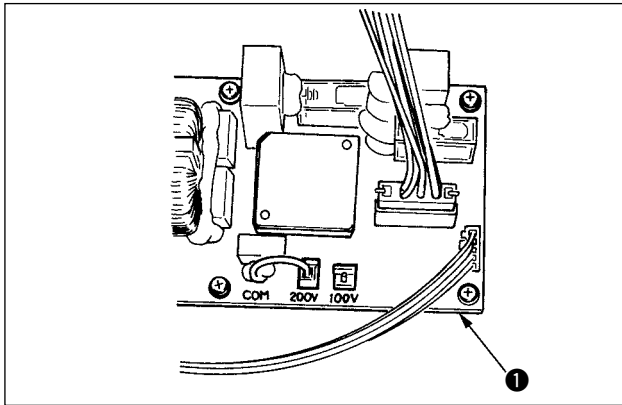

Changing procedure of the changeover connector

1. Turn OFF the power source with the power switch after confirming that the sewing machine has stopped.
2. Draw out the power cord from the power plug socket after confirming that the power switch is turned OFF. Then wait for five minutes or more.
3. Remove the front cover.
4. Remove four screws fixing the rear cover of the control box and slowly open the rear cover.

A. In case of using with 3-phase 200V to 240V

- Changing the changeover connector
Connect to 200V the 100/200V changeover connector of FLT p.c.b. ❶ located on the side of the Box Side of the control box.
- Connect the crimp style terminal of AC input cord to the power plug as shown in the figure.

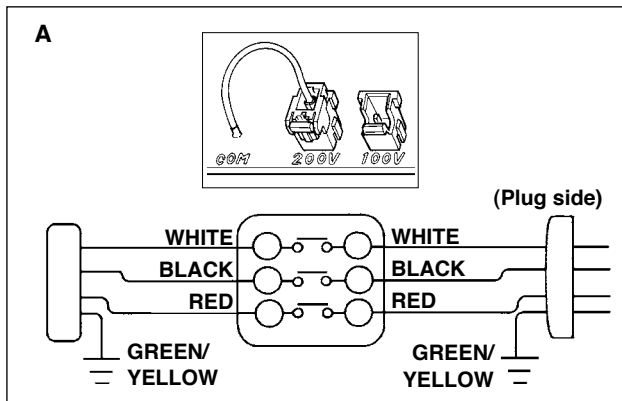

B. In case of using with single phase 100V to 120V

- Changing the changeover connector
Connect to 100V the 100/200V changeover connector of FLT p.c.b. ❶ located on the side of the Box Side of the control box.
- Connect the crimp style terminal of AC input cord to the power plug as shown in the figure.

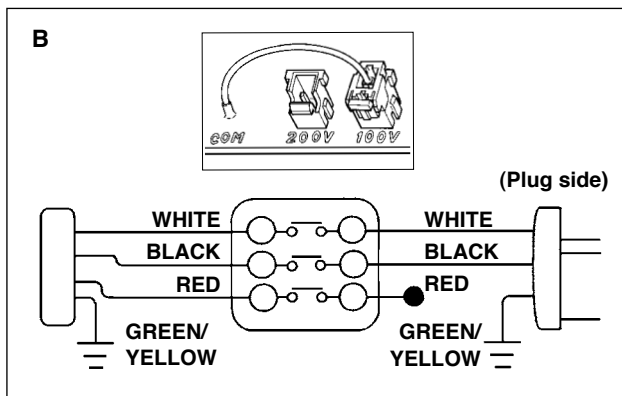

(Caution) Securely perform the insulation treatment to the red terminal which is not used with insulation tape or the like. (When the insulation is insufficient, there is a danger of electric shock or leakage current.)

C. In case of using with single phase 200V to 240V

- Changing the changeover connector
Connect to 200V the 100/200V changeover connector of FLT p.c.b. ❶ located on the side of the Box Side of the control box.
- Connect the crimp style terminal of AC input cord to the power plug as shown in the figure.

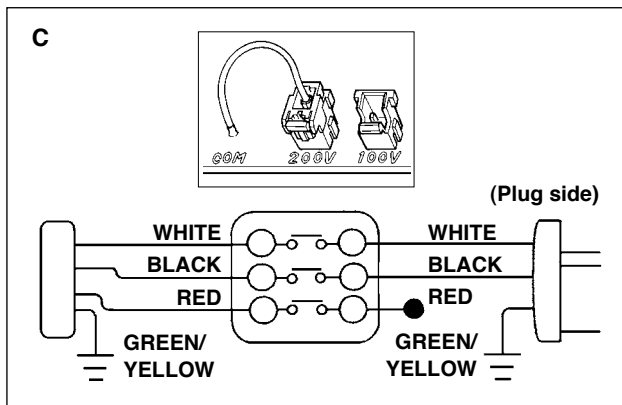

(Caution) Securely perform the insulation treatment to the red terminal which is not used with insulation tape or the like. (When the insulation is insufficient, there is a danger of electric shock or leakage current.)

5. Check that the change has been performed without fail before closing the rear cover.
6. Be careful that the cord is not pinched between the rear cover and the control box main unit. Close the rear cover while pressing the lower side of rear cover, and tighten four screws.

11. Replenishing the designated places with grease

When the sewing machine has been used for a certain number of times of sewing, error code No. E220 is displayed on the operation panel at the time of turning ON the power. This display informs the operator of the time of replenishing the designated places with grease. Be sure to replenish the places with the grease below. Then call the memory switch No. 245 and set it to "0" with the RESET key.

Even after the display of the error No. E220, when the RESET key is pressed, the error is released, and the sewing machine can be continuously used. Afterwards, however, the error No. E220 is displayed every time the power is turned ON.

In addition, when the sewing machine is used further for a certain period of time after the display of error No. E220, the error No. E221 is displayed and the sewing machine fails to operate since the error cannot be released even when the RESET key is pressed.

When the error No. E221 is displayed, be sure to replenish the designated places below with grease. Then start up the memory switch and set No. 245 to "0" with the RESET key.



1. After replenishing the places with grease, the error No. E220 or No. E221 is displayed again unless the memory switch No. 245 is changed to "0".
2. Use grease tube (Part No. 40013640) supplied as accessories to replenish the designated places below with grease. If grease other than the designated one is replenished, damage of components will be caused.



WARNING :

Turn OFF the power before starting the work so as to prevent accidents caused by abrupt start of the sewing machine.

(1) Replenishing the eccentric cam section with grease

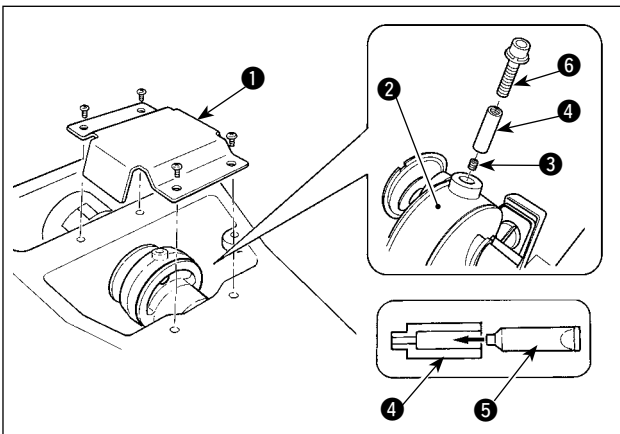

- 1) Open crank rod cover ①.
- 2) Remove setscrew ③ from the grease inlet cover located at periphery of crank rod ②.
- 3) Fill coupling ④ with grease through JUKI Grease B tube ⑤.
- 4) Sink screw ⑥ supplied with the unit into the coupling to add the grease.
- 5) After adding the grease, securely tighten setscrew ③ which has been removed.

(2) Replenishing the oscillator pin section with grease

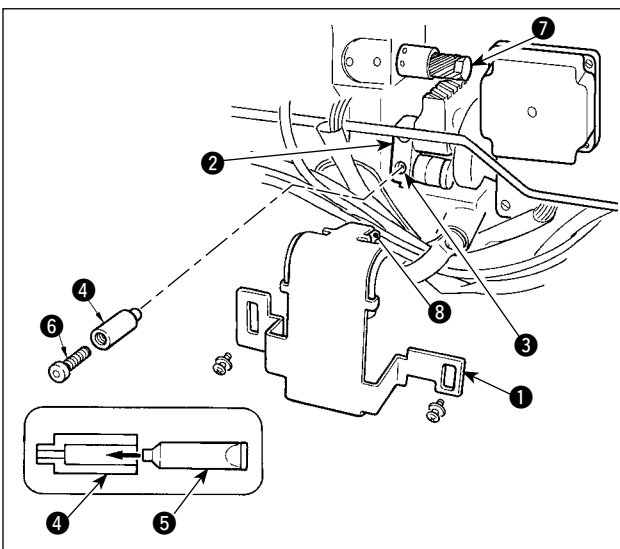

- 1) Tilt the machine head and remove the grease cover ①.
- 2) Remove setscrew ③ in oscillator gear ②.
- 3) Fill coupling ④ with grease through JUKI Grease B tube ⑤.
- 4) Sink screw ⑥ supplied with the unit into the coupling to add the grease.
- 5) Securely tighten setscrew ③ which has been removed after replenishing with the grease.
- 6) Install grease cover ① at the location where felt ⑧ comes in contact with gear ⑦.

1. Do not strongly press felt ⑧ against gear ⑦. It can cause a moving failure.
2. JUKI grease A is applied to felt ⑧. Do not add JUKI grease B to the felt.

[8] HOW TO USE THE MEMORY SWITCH

The sewing machine operation can be changed by changing the setting of the memory switch.

1. Start and change of the memory switch

- 1) When **M** key is pressed in the state that the sewing LED is put out, the memory switch setting mode is obtained.

1.32 which is indicated when "M" key is pressed indicates that the max. speed limitation of the first memory switch is 3,200 sti/min. (State at the time of delivery from the factory)



Three figures from the top are memory switch Nos.

Two figures from the bottom are contents of setting.

- 2) Change the memory switch No. with **+/-** or **-/-** key.

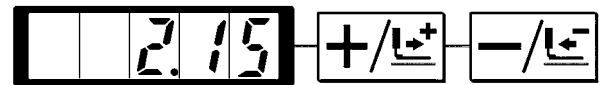

- 3) Adjust the memory switch No. to the No. you desire to change, and press **U** key. The sewing LED lights up.

- 4) Change the contents of the memory switch with **+/-** or **-/-** key.



- 5) The value can be returned to the value at the time of delivery from the factory with **/** key.
6) Press **U** key to register the contents of change. Sewing LED goes off and the mode returns to the selective state of the memory switch No.
7) Press **M** key to finalize the memory switch setting mode and the mode returns to the normal mode.

2. Example of the memory switch setting

(1) Setting the max. sewing speed limitation

Setting example : Setting the max. sewing speed limitation to 1,800 sti/min

- 1) Press **M** key in the state that the sewing LED is put out.



The memory switch is started and the contents of memory switch No. 1 are indicated.

It is not necessary to change the sewing speed since the max. speed limitation of the sewing machine is set with memory switch No. 1. The indicated memory switch No. can be changed over with **+/-** or **-/-** key.



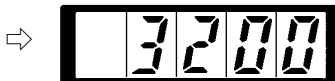

- 2) Press  key in the state that memory switch No. 1 is indicated to make the sewing LED light up. The contents of memory switch No. 1 (max. sewing speed limitation value of the sewing machine) are indicated.



- 3) Set "1800" with  or  key.



- 4) Register the value with  key. Sewing LED goes off.
5) Press  key to return to the normal state.



The sewing machine speed in the normal state cannot be increased more than the value which has been set here.

(2) Setting the soft start speed at the sewing start

The speed of the first stitch to the fifth stitch at the sewing start can be set in a unit of 100 sti/min. Two kinds of settings, in case of with needle thread clamp and of without needle thread clamp can be performed. (See " I .[8] -3. Table of functions of the memory switch" p.42.)

In case of with needle thread clamp Unit : sti/min

	State when delivered	Setting range
1st stitch	1500	400 to 1500
2nd stitch	3200	400 to 3200
3rd stitch	3200	400 to 3200
4th stitch	3200	400 to 3200
5th stitch	3200	400 to 3200





For the max. sewing speed, the memory switch No. 1 (max. sewing speed limitation) has priority.

Setting example : In case of with needle thread clamp, the speed is changed as follows.

1st stitch from 1,500 to 1,000 sti/min and 2nd stitch from 3,200 to 2,000 sti/min

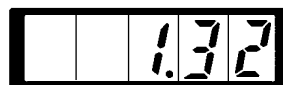
- 1) Press  key in the state that the sewing LED is put out. ⇒









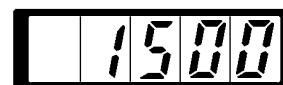







- 2) Indicate memory switch No. 2 with  or  key. Here, set the sewing speed of the first stitch.



- 3) Press  key. The sewing LED lights up and the set value of the first stitch is indicated. ⇒





- 4) Indicate "1000" with  or  key. The value returns to the initial value at the time of delivery from the factory with  key. Press  key to cancel the operation here and return to the state of step 2).
- 5) Press  key. The sewing LED goes off and the set value of the first stitch is registered.
- 6) Indicate memory switch No. 3 with  or  key. Here, set the sewing speed of the second stitch.
- 7) Press  key The sewing LED lights up and the set value of the second stitch is indicated.
- 8) Indicate "2000" with  or  key. The value returns to the initial value at the time of delivery from the factory with  key. Press  key to cancel the operation here and return to the state of step 6).
- 9) Press  key. The sewing LED goes off and the set value of the second stitch is registered.
- 10) Press  key. The memory switch setting mode is finalized and the mode returns to the normal mode.















(3) Setting whether the calling of pattern data is operative or not

By making inoperative the calling of the unnecessary pattern, this setting prevents the different pattern from calling by mistake.

Also, it is possible to call and use the necessary pattern.











Setting example : Make the calling of pattern Nos. 2 and 3 inoperative.

- 1) Press  key in the state that the sewing LED is put out.
- 2) Indicate memory switch No. 201 with  or  key.

- 3) Press  key. The sewing LED lights up and the set value of pattern No. 1 is indicated.
Set value 1 : Calling is operative.
Set value 0 : Calling is inoperative. 
- 4) Set pattern No. 2 with  or  key. 
- 5) Set the set value to "0" with  key. 
- 6) Set pattern No. 3 with  or  key. 
- 7) Set the set value to "0" with  key. 
- 8) Press  key to register the set value. The sewing LED goes off. 
- 9) Press  key. The memory switch setting mode is finalized and the mode returns to the normal mode.

(4) Setting the counter operation

Setting example : The production counter (adding method) can be changed to the bobbin thread counter (subtracting method).

- 1) Press  key in the state that the sewing LED is put out. 
- 2) Indicate memory switch No. 18 with  or  key. 
- 3) Press  key. The sewing LED lights up and the set value of counter motion is indicated. 
- 4) Set the set value to "1" with  key.
Set value 0 : Production counter
Set value 1 : Bobbin thread counter 
- 5) Press  key to register the set value. The sewing LED goes off.
- 6) Press  key. The memory switch setting mode is finalized and the mode returns to the normal mode.

3. Table of functions of the memory switch

Various operations of sewing machine can be set in programs by operating the memory switches.
There are items that change the initial values at the time of delivery according to the models.

Indication	Function	Setting range	State when delivered	Remarks
	Max. sewing speed (Speed can be set in a unit of 100 sti/min.)	400 to 3200	3200	For LK-1903AN and LK-1900ANW set to 2700.
	Sewing speed of 1st stitch (With needle thread clamp) (Speed can be set in a unit of 100 sti/min.)	400 to 1500	1500	
	Sewing speed of 2nd stitch (With needle thread clamp) (Speed can be set in a unit of 100 sti/min.)	400 to 3200	3200	
	Sewing speed of 3rd stitch (With needle thread clamp) (Speed can be set in a unit of 100 sti/min.)	400 to 3200	3200	
	Sewing speed of 4th stitch (With needle thread clamp) (Speed can be set in a unit of 100 sti/min.)	400 to 3200	3200	
	Sewing speed of 5th stitch (With needle thread clamp) (Speed can be set in a unit of 100 sti/min.)	400 to 3200	3200	
	Thread tension of 1st stitch (With needle thread clamp)	0 to 200	200	
	Thread tension at the time of thread trimming	0 to 200	0	
	Changeover timing of thread tension at the time of thread trimming	-6 to 4	0	
	Sewing speed of 1st stitch (Without needle thread clamp) (Speed can be set in a unit of 100 sti/min.)	400 to 1500	400	
	Sewing speed of 2nd stitch (Without needle thread clamp) (Speed can be set in a unit of 100 sti/min.)	400 to 3200	900	
	Sewing speed of 3rd stitch (Without needle thread clamp) (Speed can be set in a unit of 100 sti/min.)	400 to 3200	3200	
	Sewing speed of 4th stitch (Without needle thread clamp) (Speed can be set in a unit of 100 sti/min.)	400 to 3200	3200	
	Sewing speed of 5th stitch (Without needle thread clamp) (Speed can be set in a unit of 100 sti/min.)	400 to 3200	3200	
	Thread tension of 1st stitch (Without needle thread clamp)	0 to 200	0	
	Changeover timing of thread tension at the sewing start (Without needle thread clamp)	-5 to 2	-5	
	Setting whether or not indication or change of X/Y scale rate and max. speed limitation is acceptable. (Prevention of misapplication)	0 : Operative 1 : Inoperative	0	In case of setting 1, use of M key is prohibited as well. When changing memory switch, pressing M key, turn ON the power switch.

Indication	Function	Setting range	State when delivered	Remarks
	Counter operation	0 : Production counter (adding) 1 : Bobbin thread counter (subtracting)	0	
	Selection of pedal	0 : Standard pedal 1 : Standard pedal (2-step stroke) 2 : Optional pedal 3 : Optional pedal (2-step stroke)	0	
	Selection of start pedal	0 : Standard pedal 1 : Optional pedal	0	
	Optional pedal 1 operation	0 : OFF when depressing pedal again 1 : OFF when detaching from pedal	0	
	Optional pedal 2 operation	0 : OFF when depressing pedal again 1 : OFF when detaching from pedal	0	
	Height of work clamp foot at the time of 2-step stroke	50 to 90	70	Height is lowered when the set value is increased.
	Selection of base point of pattern enlargement/reduction	0 : origin 1 : Sewing start point	0	
	Sewing machine operation can be stopped with panel key (clear key).	0 : Ineffective 1 : Panel reset key 2 : External switch	0	
	Buzzer sound can be prohibited.	0 : Without buzzer sound 1 : Panel operation sound 2 : Panel operation sound + error sound	2	
	Number of stitches that needle thread clamp releases is set.	1 to 7 stitches	2	
	Clamping timing of needle thread clamp can be delayed.	-10 to 0	0	Timing is delayed in “-” direction.
	Needle thread clamp control can be prohibited.	0 : Normal 1 : Prohibited	0	Misapplication of panel is protected. For LK-1903AN, set to “1”.
	Feed timing is selected. When stitches are not well-tightened, set the value in “-” direction.	-8 to 16	12	Setting on excessive “-” side may cause needle breakage. Be careful when sewing heavy-weight material.
	State of work clamp foot after completion of sewing can be selected.	0 : Work clamp foot goes up after moving at the sewing start 1 : Work clamp foot goes up immediately after the end of sewing. 2 : Work clamp foot goes up by pedal operation after moving at the sewing start.	1	For LK-1903AN/BR35, set to “0”.
	Execution of origin retrieval every time after completion of sewing can be performed. (Except cycle stitching)	0 : Without origin retrieval 1 : With origin retrieval	0	
	Setting of origin retrieval in cycle stitching can be set.	0 : Without origin retrieval 1 : Every time 1 pattern is completed 2 : Every time 1 cycle is completed	0	

Indication	Function	Setting range	State when delivered	Remarks
	State of work clamp foot when machine stopped by temporary stop command can be selected.	0 : Work clamp foot goes up. 1 : Work clamp foot goes up with work clamp foot switch. 2 : Lift of work clamp foot is prohibited.	0	
	Needle bar stop position is set.	0 : UP position 1 : Upper dead point	0	Needle bar rotates in the reverse direction after the UP position stop and stops when upper dead point stop is set.
	Thread trimming can be prohibited.	0 : Normal 1 : Thread trimming prohibited	0	
	Route of origin return by means of clear key can be selected.	0 : Straight line return 1 : Reverse return of pattern	0	This function is used when straight line return from the midway of pattern to the start of sewing is not possible.
	Bobbin winding speed can be set.	800 to 2,000	1600	Max. speed limitation has priority.
	Operation timing of material closing is selected. LK-1901AN only	0 : Output prohibited 1 : Operation when work clamp foot comes down. 2 : Operation at the time of start	2	For the machines other than LK-1901AN, this function is not indicated.
	Wiper operation method can be selected.	0 : Without wiper at the time of thread trimming on the way 1 : With wiper at the time of thread trimming on the way ① 2 : With wiper at the time of thread trimming on the way ② 3 : Magnet wiper	1	① : Without return of the last wiper ② : With return of the last wiper
	Tie stitching at the start of sewing of the pattern for button sewing can be prohibited. For LK-1903AN only	0 : Tie stitching effective 1 : Tie stitching ineffective	0	For the machines other than LK-1903AN, thus function is not indicated.
	Position of origin moves 5 mm to the front.	0 : Standard 1 : Front	0	Necessary to set this function when using work clamp foot and pattern of LK-1904
	This function sets whether or not the calling of the pattern data is operative.	0 : Calling inoperative 1 : Calling operative	Setting depends on the model used.	Service pattern Nos. 1 to 64 can be individually set.
	Grease replenishing time information counter		-	Refer to the item " I .[7]-11. Replenishing the designated places with grease" p.37.
	Register of the pattern is performed.			Refer to the item " I .[6]-1. Performing sewing using the pattern keys" p. 24.
	Register of the cycle stitching is performed.			Refer to the item " I .[6]-2. Performing sewing using the combination function" p. 27.

[9] OTHERS

1. Setting the DIP switch

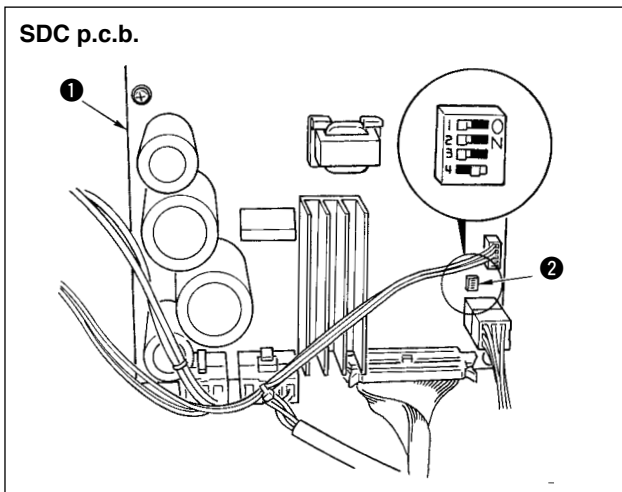

When "4" of DIP switch ② on SDC circuit board ① is turned ON, the penetrating force is increased. Turn it ON when the penetrating force is insufficient.

Turn OFF all DIP switches other than the switch above.

Caution Perform the changeover of DIP switch after turning OFF the power.

Caution Be very careful of the heat of the main shaft motor.

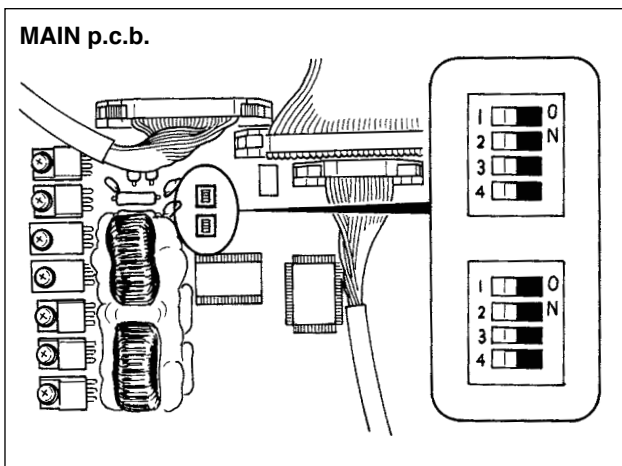

Turn OFF all DIP switches of MAIN p.c.b.

2. Table of the standard pattern specifications

NO	Lengthwise	Crosswise	Number of stitches	Pattern	S, F, H	M
1	2.0	16	42	Large size bartacking	*	
2	2.0	10	42	Large size bartacking	*	
3	2.5	16	42	Large size bartacking	*	
4	3.0	24	42	Large size bartacking		
5	2.0	10	28	Large size bartacking	*	
6	2.5	16	28	Large size bartacking	*	
7	2.0	10	36	Large size bartacking	*	
8	2.5	16	36	Large size bartacking	*	
9	3.0	24	56	Large size bartacking		
10	3.0	24	64	Large size bartacking		
11	2.5	6	21	Small size bartacking (eyelet)	*	
12	2.5	6	28	Small size bartacking (eyelet)	*	
13	2.5	6	36	Small size bartacking (eyelet)	*	
14	2.0	8	14	Knit goods bartacking	*	*
15	2.0	8	21	Knit goods bartacking	*	*
16	2.0	8	28	Knit goods bartacking	*	*
17	0	10	21	Straight line bartacking	*	
18	0	10	28	Straight line bartacking	*	
19	0	25	28	Straight line bartacking		
20	0	25	36	Straight line bartacking		
21	0	25	41	Straight line bartacking		
22	0	35	44	Straight line bartacking		
23	20	4.0	28	Lengthwise bartacking		
24	20	4.0	36	Lengthwise bartacking		
25	20	4.0	42	Lengthwise bartacking		
26	20	4.0	56	Lengthwise bartacking		
27	20	0	18	Lengthwise straight line bartacking		
28	10	0	21	Lengthwise straight line bartacking		
29	20	0	21	Lengthwise straight line bartacking		
30	20	0	28	Lengthwise straight line bartacking		
38	2.0	8	28	Knit goods bartacking	*	*

In the condition of delivery from the factory, the pattern sewing with * marks can be made.

When using the standard patterns other than the patterns with * marks, refer to “**I .[8]-2.(3) Setting whether the calling of the pattern data is operative or not**” p.40 described in the item of the how to use the memory switch.

3. Table of the standard patterns

	No	Stitch diagram	Number of stitches	Sewing size (mm)		(Note 2) No. of work clamp foot
				Length-wise	Cross-wise	
Large size bartacking	1 (51)		42	2.0	16	1
	2					2
						3
	3 ※		2.5	16	1	
					4	
	4 ※		3.0	24	6	
					7	
	5		2.0	10	1	
					2	
	6 ※		2.5	16	1	
4						
7		2.0	10	1		
				2		
8 ※		2.5	16	1		
				4		
9 ※		3.0	24	6		
				7		
10 ※		3.0	24	6		
				7		
Small size bartacking	11		21	2.5	6	8
	12		28	2.5	6	
	13		36	2.5	6	
Knit goods bartacking	14		14	2.0	8	5
	15		21	2.0	8	
	16		28	2.0	8	
Straight line bartacking	17		21	0	10	1
	18					2
						3
	19		0	25	6	
					7	
	20		36	0	25	6
21		41	0	25	6	
22		44	0	35	(Note3)	
Lengthwise bartacking	23		28	20	4.0	9
	10					
	24		36	20	4.0	9
	10					
	25		42	20	4.0	9
10						
26		56	20	4.0	9	
10						
Lengthwise straight line bartacking	27		18	20	0	11
	28					21
	29		20	0		
	30				28	20

- 1. Sewing size shows the dimensions when the scale rate is 100%.**

2. Refer the No. of work clamp foot to the separate table of work clamp foot.

3. For No. 22, process the work clamp foot blank for use.

4. Use the patterns with ※ marks for sewing denim.

5. No. 51 is for the machine without thread clamp device.



	No	Stitch diagram	Number of stitches	Sewing size (mm)		(Note 2) No. of work clamp foot
				Length-wise	Cross-wise	
Semi-lunar bartacking	31		52	7	10	13
	32		63	7	12	13
	33		24	6	10	13
	34		31	6	12	13
	35		48	10	7	14
	36		48	10	7	14
Large size bartacking	37		90	3	24	6
			7			
Knit goods bartacking	38		28	2	8	5
Round bartacking	39		28	ø12		16
	40		48			

(Caution)

Pattern Nos. 41 to 46 are for the optional work clamp foot No. 12. The origin of the patterns is different by 5 mm up and down from that of lengthwise bartacking pattern Nos. 23 to 26.

	No	Stitch diagram	Number of stitches	Sewing size (mm)		(Note 2) No. of work clamp foot	
				Length-wise	Cross-wise		
Lengthwise bartacking	41		29	20	2.5	12	
	42		39	25	2.5	12	
	43		45	25	2.5	12	
	44		58	30	2.5	12	
	45		75	30	2.5	12	
	46		42	30	2.5	12	
	Radial tacking	47		91	ø8		15
		48		99			
		49		148			
		50		164			

4. Table of the work clamp foot

	1	2	3	4	5
Work clamp foot	13518659 (asm.)			13548557 (asm.)	13542964 (asm.)
Feed plate	14116107	14116404	14116800	14116305	14116206
	(With knurl)	(Without knurl)	(Without knurl)	(With knurl)	(With knurl)
Sewingspecification	S	F	F	H / W	M
※ Finger guard	13533104				
Remarks	Standard accessory for S (standard) type machine head.	Supplied with F (foundation) type machine head. (Depends on the destination)		Optional	Standard accessory for M (knit goods) type machine head.

※ Install a finger guard suitable for each work clamp foot when replacing the work clamp foot.

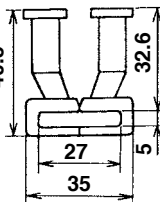
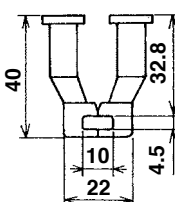
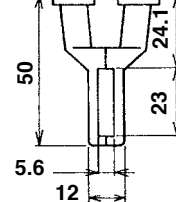
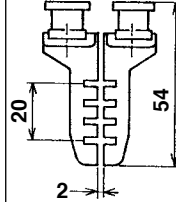
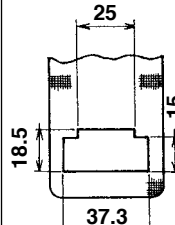
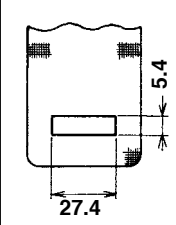
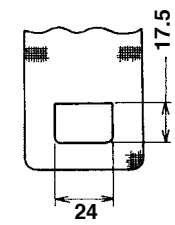
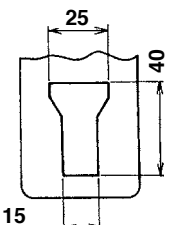
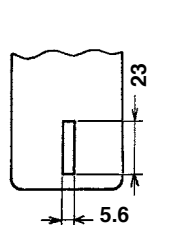
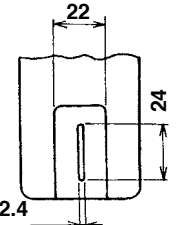
	6	7	8	9	10	11
Work clamp foot	13548151(asm.)		13542451 (asm.)	13571955 (asm.)		13561360 (asm.)
						
Feed plate	13548003 (With knurl)	13554803 (With knurl)	14116602 (With knurl)	14116503 (Without knurl)	14116909 (Without knurl)	14116701 (Without knurl)
						
Sewing specification	S	H / W	S	F	F	F
※ Finger guard	13548300		13533104	13573407		
Remarks	Optional	Standard accessory for H type (Heavy-weight material) and W type(Double-capacity hook) machine head.	Optional	Accessory part for F (foundation) type. (Depends on the destination)		Optional

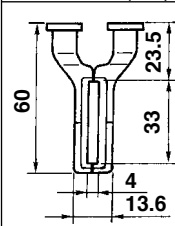
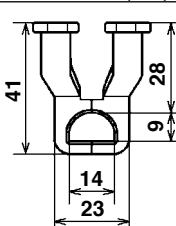
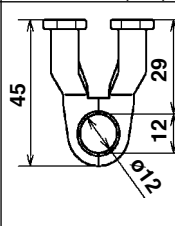
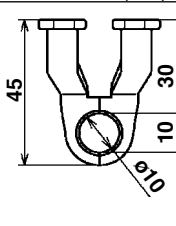
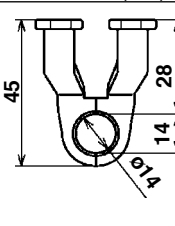
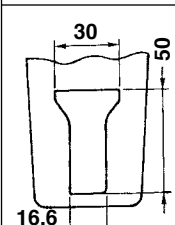
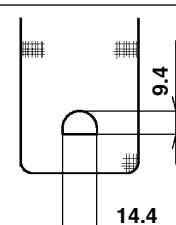
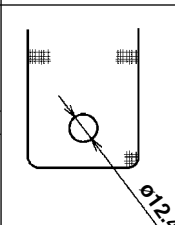
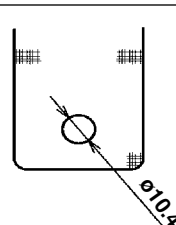
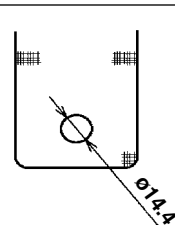
	12	13	14	15	16
Work clamp foot	14137509 (right) 14137608 (left)	40021871 (right) 40021872 (left)	40021874 (right) 40021875 (left)	40021877 (right) 40021878 (left)	40021880 (right) 40021881 (left)
					
Feed plate	14137707 (Without knurl)	40021873 (With knurl)	40021876 (With knurl)	40021879 (With knurl)	40021882 (With knurl)
					
Sewing specification	F	S	S	S	S
※ Finger guard	14135305	13533104			
Remarks	Optional	Optional	Optional	Optional	Optional

※ Install a finger guard suitable for each work clamp foot when replacing the work clamp foot.

5. LK-1900 data ROM

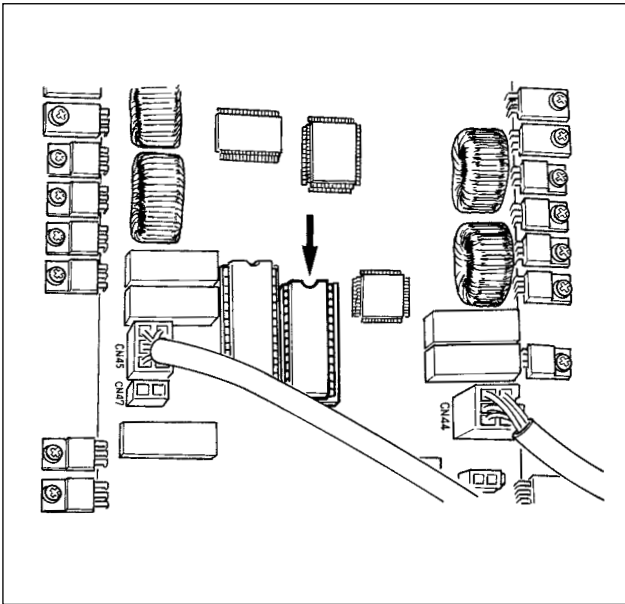

Insert LK-1900 data ROM to the IC socket on MAIN p.c.b for use.

1. Be careful of the inserting direction.
2. EEPROM cannot be used.
3. When the pattern No. is the same as that of the standard pattern, the pattern in the data ROM is prior to other pattern.



ROM which can be used :

27C256 EPROM

JUKI Part No. : HL008423000

6. Connection of the optional pedal

(1) Connection of PK-57

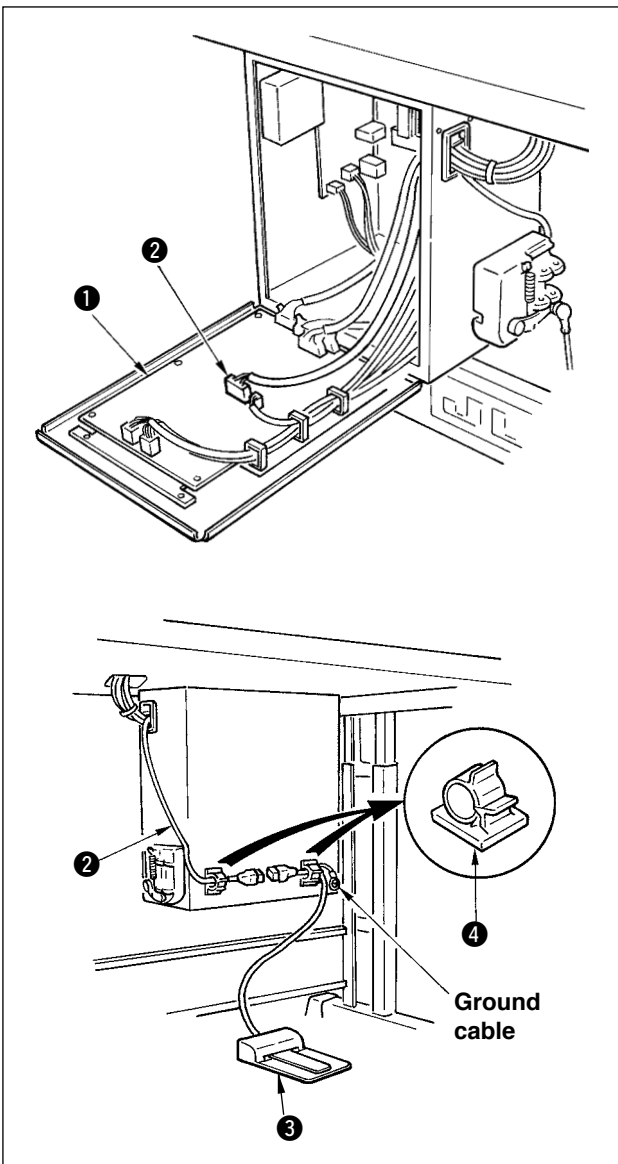

- 1) Connect PK-57 change cable ② with CN41 of MAIN circuit board ① .
- 2) Connect the cord of PK-57 ③ with the PK-57 change cable at the rear face of the control box. Then clamp two places with adhesive clamp ④ . In addition, tighten with a screw the PK-57 ground cable as illustrated in the figure.

PK-57 : Part No. GPK570010B0

PK-57 change cable : Part No. M90135900A0

Adhesive clamp : Part No. E9607603000

- 3) Set the memory switches as follows.

Memory switch No.	Set value
19	2
20	1
24	1

7. Error list

Indication	Name of error	Description of error	Corrective measure	Remarks
E 17	Machine lock error	The main shaft of the sewing machine does not rotate due to some troubles.	Turn OFF the power switch and remove the cause of troubles.	
E 18	Pattern No. error	Back-uped pattern No. has not been registered in the data ROM, or it is set to readout inoperative. Pattern No. is set to "0".	Press the reset switch and check the pattern No. Check the contents of memory switch No. 201.	
E 30	Needle bar position error	Needle bar is not in the specified position.	Turn the hand pulley to return the needle bar to its specified position.	
E 40	Sewing area over	The sewing area is beyond the limit.	Press the reset switch and check the pattern and X/Y scale rate.	This error is output when max. sewing area, 30 x 40 is over. Interference of the work clamp foot with needle is not protected.
E 43	Enlargement error	The sewing pitch is beyond 10 mm.	Press the reset switch and check the pattern and X/Y scale rate.	
E 45	Pattern data error	The pattern data cannot be adopted.	Turn OFF the power switch and check the data ROM.	
E 50	Temporary stop	Temporary stop by operating the reset switch while the sewing machine is running. (Refer to memory switch No. 31.)	Re-start or return-to-origin after thread trimming by means of the reset switch (For the details, refer to the item "I.[6]-4.How to use the temporary stop", p.29.)	
E 63	Machine head identification error	The type of machine head and the type of control box do not match.	Turn the power OFF and contact JUKI or your distributor.	
E 220	Grease replenishing time information	Information as to the time of replenishing the designated places with grease	Replenish the designated places with grease and set memory switch No. 245 to "0" with the reset key. Error can be released with the reset key when immediate replenishing with grease cannot be performed during sewing operation.	Refer to the item "I.[7]-11. Replenishing the designated places with grease" p.37.
E 221	Grease replenishing warning error	Sewing machine has stopped since the time of replenishing the designated places with grease has come.	Immediately perform replenishing with grease and set memory switch No. 245 to "0" with the reset key.	Refer to the item "I.[7]-11. Replenishing the designated places with grease" p.37.
E 302	Head tilt error	Head tilt detection switch is turned ON.	The sewing machine cannot be operated with the head tilted.Return the sewing machine head to its proper position.	
E 303	Z phase detection error	Detection of the upper dead point of the sewing machine cannot be performed.	Turn OFF the power switch and check whether CN14 of SDC circuit board is disconnected or loose.	
E 305	Thread trimmer position error	The thread trimmer is not in the proper position.	Turn OFF the power switch and check whether CN66 of INT circuit board is disconnected or loose.	

Indication	Name of error	Description of error	Corrective measure	Remarks
E 306	Needle thread clamp position error	The needle thread clamp device is not in the proper position.	Turn OFF the power switch and check whether CN65 of INT circuit board is disconnected or loose.	
E 730	Encoder trouble A	Encoder A or B phase cannot be detected.	Turn OFF the power switch and check whether CN14 is loose or disconnected.	
E 731	Encoder trouble B	Encoder U, V or W phase cannot be detected.	Turn OFF the power switch and check whether CN14 is loose or disconnected.	
E 733	Reverse rotation of motor	The motor is reversing.	Turn OFF the power switch and check whether coupling of the main motor is loose.	
E 811	Overvoltage error	Power source voltage is beyond the specified value.	Check the power source voltage.	
E 813	Low voltage error	Power source voltage is short.	Check the power source voltage.	
E 901	Motor driver trouble	Error from the motor driver is detected.	Turn OFF the power switch and turn ON the power switch again after some time.	
E 903	Stepping motor power source trouble	Power source of the stepping motor is not output.	Turn OFF the power switch and check F1 fuse of SDC circuit board.	Check the cause of blown-out of the fuse.
E 904	Solenoid power source trouble	Power source of the solenoid is not output.	Turn OFF the power switch and check F2 fuse of SDC circuit board.	Check the cause of blown-out of the fuse.
E 905	SDC circuit board overheat	Overheat of SDC circuit board	Turn OFF the power switch and turn ON the power switch again after some time.	
E 907	X origin retrieval error	X origin sensor does not change.	Turn OFF the power switch and check whether CN62 of INT circuit board or CN42 of MAIN circuit board is disconnected or loose.	
E 908	Y origin retrieval error	Y origin sensor does not change.	Turn OFF the power switch and check whether CN63 of INT circuit board or CN43 of MAIN circuit board is disconnected or loose.	
E 910	Work clamp foot origin retrieval error	Work clamp foot origin sensor does not change.	Turn OFF the power switch and check whether CN64 of INT circuit board or CN44 of MAIN circuit board is disconnected or loose.	
E 913	Needle thread clamp origin retrieval error	Needle thread clamp origin sensor does not change.	Turn OFF the power switch and check whether CN65 of INT circuit board or CN45 of MAIN circuit board is disconnected or loose.	
E 914	Feed trouble error	Timing lag between feed and main shaft has occurred.	Turn OFF the power switch and check whether coupling of the main motor is loose.	

Indication	Name of error	Description of error	Corrective measure	Remarks
E 915	Communication error between panel and MAIN	Communication between the panel and MAIN cannot be performed.	Turn OFF the power switch and check whether CN34 of MAIN circuit board is loose.	
E 916	Communication error between panel and SDC	Communication between MAIN and SDC cannot be performed.	Turn OFF the power switch and check whether CN32 of MAIN circuit board or CN15 of SDC circuit board is disconnected or loose.	
E 918	MAIN circuit board overheat	Overheat of MAIN circuit board	Turn OFF the power switch and turn ON the power switch again after some time.	
E 947	MAIN memory write-in trouble	Memory write-in of MAIN circuit board cannot be performed.	Turn OFF the power switch and check the insertion of ROM of U22 of MAIN circuit board.	
E 946	INT memory write-in trouble	Memory write-in of the head circuit board cannot be performed.	Turn OFF the power switch and check whether CN38 of MAIN circuit board is disconnected or loose.	
	Abnormal power source Disconnection of connector	Power source voltage type is different. The connector is disconnected.	Turn OFF the power switch and check the power source voltage and check whether CN3 of FLT circuit board or CN13 of SDC circuit board is disconnected or loose.	
	(Without indication)			

8. Troubles and corrective measures (sewing conditions)

Trouble	Cause	Corrective measures	Page
1. The needle thread slips off at the start of bar-tacking.	① Stitches are slipped at the start.	○ Adjust the clearance between the needle and the shuttle to 0.05 to 0.1 mm.	32
	② The needle thread remaining on the needle after thread trimming is too short.	○ Set soft-start sewing at the start of bartacking.	38
	③ The bobbin thread is too short.	○ Correct the thread tension release timing of the thread tension controller No. 2.	16
	④ Needle thread tension at 1st stitch is too high.	○ Increase the tension of the thread take-up spring, or decrease the tension of the thread tension controller No. 1.	15
	⑤ Thread clamp is unstable (material is apt to be expanded, thread is hard to slide, thread is thick, etc.).	○ Decrease the tension of the bobbin thread.	33
	⑥ Pitch at 1st stitch is too small.	○ Increase the clearance between the needle hole guide and the counter knife. ○ Decrease the tension at 1st stitch.	
2. Thread often breaks or synthetic fiber thread splits finely.	① The shuttle or the driver has scratches.	○ Decrease the number of rotation at 1st stitch at the sewing start. (Extent of 600 to 1,000 sti/min)	33
	② The needle hole guide has scratches.	○ Increase the number of stitches of thread clamp to 3 to 4 stitches.	
	③ The needle strikes the work clamp foot.	○ Make the pitch at 1st stitch longer.	15
	④ Fibrous dust is in the groove of the shuttle race.	○ Decrease the needle thread tension at 1st stitch.	
	⑤ The needle thread tension is too high.	○ Take it out and remove the scratches using a fine whetstone or buff.	16
	⑥ The tension of the thread take-up spring is too high.	○ Buff or replace it.	
	⑦ The synthetic fiber thread melts due to heat generated on the needle.	○ Correct the position of the work clamp foot.	14
3. The needle often breaks.	① The needle is bent.	○ Take out the shuttle and remove the fibrous dust from the shuttle race.	13
	② The needle hits the work clamp foot.	○ Reduce the needle thread tension.	
	③ The needle is too thin for the material.	○ Reduce the tension.	33
	④ The driver excessively bends the needle.	○ Use silicone oil.	32
	⑤ Needle thread is stepped on by the work clamp foot at the start of sewing. (Needle bend)	○ Widen the distance between the needle and the wiper. (23 to 25 mm)	34
4. Threads are not trimmed. (Bobbin thread only)	① The counter knife is dull.	○ Replace the bent needle.	33
	② The difference in level between the needle hole guide and the counter knife is not enough.	○ Correct the position of the work clamp foot.	
	③ The moving knife has been improperly positioned.	○ Replace it with a thicker needle according to the material.	32
	④ The last stitch is skipped.	○ Correctly position the needle and the shuttle.	
5. Stitch skipping often occurs.	⑤ Bobbin thread tension is too low.	○ Widen the distance between the needle and the wiper. (23 to 25 mm)	34
	① The motions of the needle and shuttle are not properly synchronized.	○ Replace the counter knife.	32
	② The clearance between the needle and shuttle is too large.	○ Increase the bend of the counter knife.	
	③ The needle is bent.	○ Correct the position of the moving knife.	33
5. Stitch skipping often occurs.	④ The driver excessively bends the needle.	○ Correct the timing between the needle and the shuttle.	32
	① The motions of the needle and shuttle are not properly synchronized.	○ Correct the positions of the needle and shuttle.	
	② The clearance between the needle and shuttle is too large.	○ Correct the positions of the needle and shuttle.	32
	③ The needle is bent.	○ Replace the bent needle.	13
5. Stitch skipping often occurs.	④ The driver excessively bends the needle.	○ Correctly position the driver.	32

Trouble	Cause	Corrective measures	Page
6. The needle thread comes out on the wrong side of the material.	<ul style="list-style-type: none"> ① The needle thread tension is not high enough. ② The tension release mechanism fails to work properly. ③ The needle thread after thread trimming is too long. ④ Number of stitches is too few. ⑤ When sewing length is short (End of needle thread protrudes on the wrong side of sewing product.) ⑥ Number of stitches is too few. 	<ul style="list-style-type: none"> ○ Increase the needle thread tension. ○ Check whether or not the tension disc No. 2 is released during bar-tracking. ○ Increase the tension of the thread tension controller No. 1. ○ Correct the position of the moving knife. ○ Turn OFF the thread clamp. ○ Turn OFF the thread clamp. ○ Use the lower plate, the hole of which is larger than the presser. 	15 15
7. Threads break at time of thread trimming.	<ul style="list-style-type: none"> ① The moving knife has been improperly position. 	<ul style="list-style-type: none"> ○ Correct the position of the moving knife. 	33
8. The thread clamp is entangled with needle thread.	<ul style="list-style-type: none"> ① The needle thread at the sewing start is too long. 	<ul style="list-style-type: none"> ○ Tighten thread tension controller No. 1 and make the length of needle thread 33 to 36 mm. 	
9. Uneven length of the needle thread	<ul style="list-style-type: none"> ① The tension of thread take-up spring is too low. 	<ul style="list-style-type: none"> ○ Increase the tension of the thread take-up spring. 	
10. The length of needle thread does not become short.	<ul style="list-style-type: none"> ① The tension of thread tension controller No. 1 is too low. ② The tension of thread take-up spring is too high. ③ The tension of thread take-up spring is too low and motion is unstable. 	<ul style="list-style-type: none"> ○ Increase the tension of thread tension controller No. 1. ○ Decrease the tension of thread take-up spring. ○ Increase the tension of thread take-up spring and lengthen the stroke as well. 	
11. The knotting section of bobbin thread at 2nd stitch at the sewing start appears on the right side.	<ul style="list-style-type: none"> ① Idling of bobbin is large. ② The bobbin thread tension is too low. ③ The needle thread tension at 1st stitch is too high. 	<ul style="list-style-type: none"> ○ Adjust the position of the moving knife. ○ Increase the bobbin thread tension. ○ Decrease the needle thread tension at 1st stitch. ○ Turn OFF the thread clamp. 	

9. Table of the optional parts

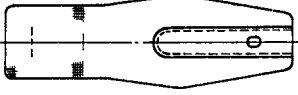
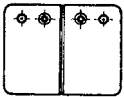
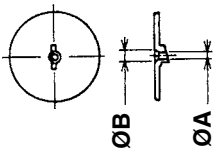
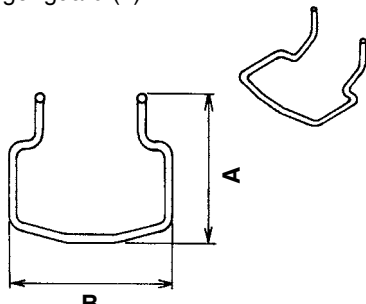
Name of Parts	Type	Part No.	Remarks	
<p style="text-align: center;">Feed plate blank</p>  <p style="text-align: center;">t = 1.2</p>	Without knurl / processed Sewing area lengthwise 20 X crosswise 40	14120109		
	With knurl / processed Sewing area lengthwise 20 X crosswise 40	14120307		
	Without knurl / stainless steel Sewing area lengthwise 20 X crosswise 40	14120505	t = 0.5	
	Without knurl / processed Sewing area lengthwise 30 X crosswise 40	40021855		
	Without knurl / without processing Sewing area lengthwise 30 X crosswise 40	40021856		
	Without knurl / stainless steel Sewing area lengthwise 30 X crosswise 40	40021857	t = 0.5	
	With knurl / processed Sewing area lengthwise 30 X crosswise 40	40021858		
	With knurl / without processing Sewing area lengthwise 30 X crosswise 40	40021859		
	Work clamp foot face plate (asm.)		14121263	Face plate for presser blank
	<p style="text-align: center;">Presser blank</p>  <p style="text-align: center;">t = 3.2</p>	With knurl / Processed (right) Sewing area lengthwise 20 X crosswise 40	14121701	
With knurl / Processed (Left) Sewing area lengthwise 20 X crosswise 40		14121800		
With knurl / Processed (right) Sewing area lengthwise 30 X crosswise 40		40021851		
With knurl / Processed (Left) Sewing area lengthwise 30 X crosswise 40		40021852		
With knurl / without processing (right) Sewing area lengthwise 30 X crosswise 40		40021853		
With knurl / without processing (Left) Sewing area lengthwise 30 X crosswise 40		40021854		
Needle hole guide		A=1.6 B=2.6 With relief slit	B2426280000	Standard type
	A=1.6 B=2.0 Without relief slit	D2426282C00	F and M types	
	A=2.3 B=4.0 Without relief slit	14109607	H and W types	
	A=2.7 B=3.7 Without relief slit	D2426MMCK00	For extra heavy-weight material	
	Finger guard (1)	A=56.5 B=64	13533104	
	A=59 B=74	13548300	For large size bartacking	

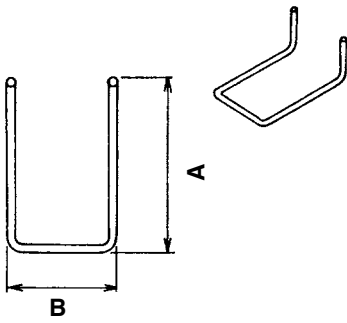
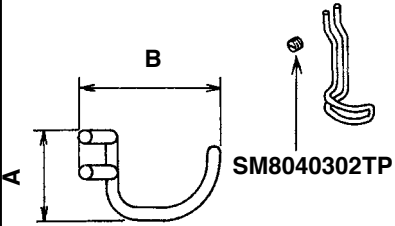
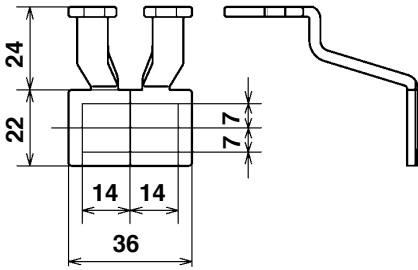
Name of Parts	Type	Part No.	Remarks
<p>Finger guard (2)</p> 	<p>A=66.5 B=43</p>	<p>13573407</p>	<p>For lengthwise bartacking</p>
<p>Finger guard (3)</p> 	<p>A=21.5 B=35.5</p>	<p>14120000</p>	<p>For specially ordered work clamp</p>
<p>Work clamp foot blan</p> 	<p>With knurl / processed (right)</p>	<p>40021869</p>	
	<p>With knurl / processed (left)</p>	<p>40021870</p>	

II. EXPLANATION OF THE LK-1901AN, COMPUTER-CONTROLLED HIGH-SPEED EYELET BUTTONHOLE BARTACKING MACHINE

1. Specifications

Different specifications from those of the LK-1900AN only are described.

1	Max. sewing speed	3.000 sti/min
2	Needle	DPx5 #14, #16
3	Lift of the work clamp foot	Max. 17mm
4	Number of standard patterns	3 patterns

2. Installation of the sewing machine and preparation of the operation



DANGER :

Be sure to perform the work with two persons or more when moving the sewing machine.

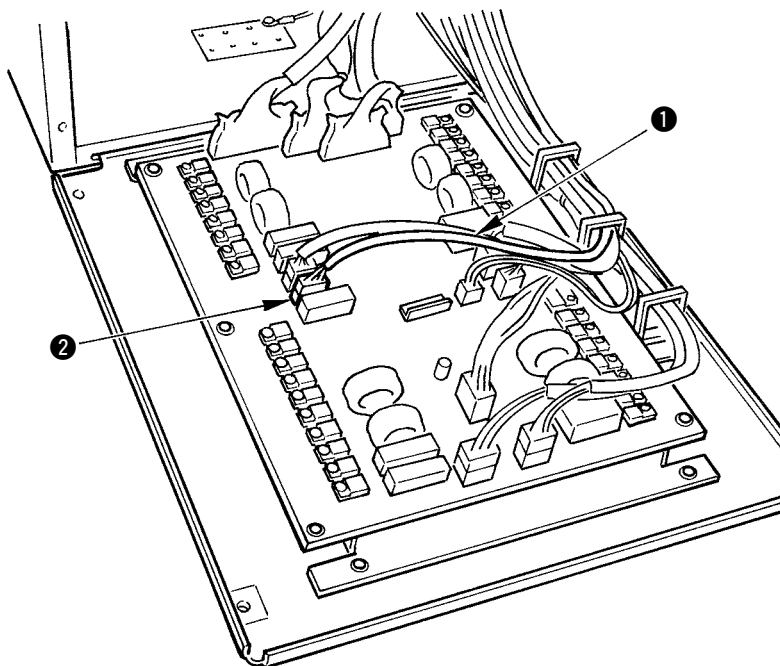

- 1) Except for the connection of the work clamp foot bracket unit solenoid, installation of LK-1901AN and preparation of the operation are the same as those of the LK-1900AN.
Refer to the instruction manual for the LK-1900AN.
- 2) Connect connector CN47 **1** of the relay cable of the work clamp foot bracket unit with connector CN47 **2** mounted on the MAIN circuit board inside the control box.

3. Adjustment of the material closing amount



WARNING :

Turn OFF the power before starting the work so as to prevent accidents caused by abrupt start of the sewing machine.

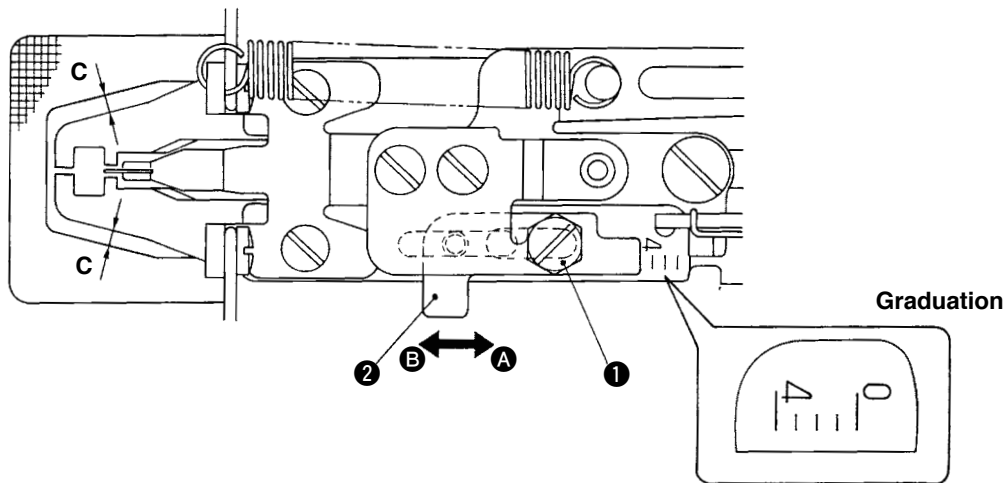

- 1) The maximum material closing amount is 4 mm. However, the amount is set to 2 mm at the time of delivery because of the relation of the feed plate window and the work clamp foot (dimension C). (Graduation position : 2)
- 2) Loosen bolt ① and move work clamp foot regulator ② in the direction of arrow to adjust the material closing amount. The material closing amount will be decreased when work clamp foot regulator ② is moved in the direction of A , and be increased when it is moved in the direction of B .



To increase the material closing amount more than 3 mm, widen the feed plate window by additional work (increase the dimension C.) so that the feed plate window does not interfere with the work clamp foot.

4. Adjustment of the lift of the work clamp foot



WARNING :

Turn OFF the power before starting the work so as to prevent accidents caused by abrupt start of the sewing machine.

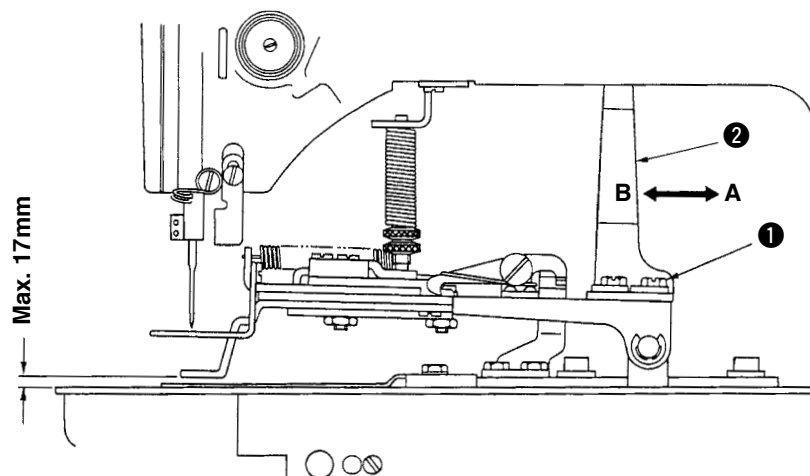

- 1) Loosen two setscrews ① and adjust by moving work clamp foot lifting plate ② back and forth in the direction of arrow. The amount of the lift of the work clamp foot will be decreased when work clamp foot lifting plate ② is moved in the direction of A, and be increased when it is moved in the direction of B. After the adjustment, securely tighten setscrews ① .

5. Adjustment of the pressure of the work clamp unit



WARNING :

Turn OFF the power before starting the work so as to prevent accidents caused by abrupt start of the sewing machine.

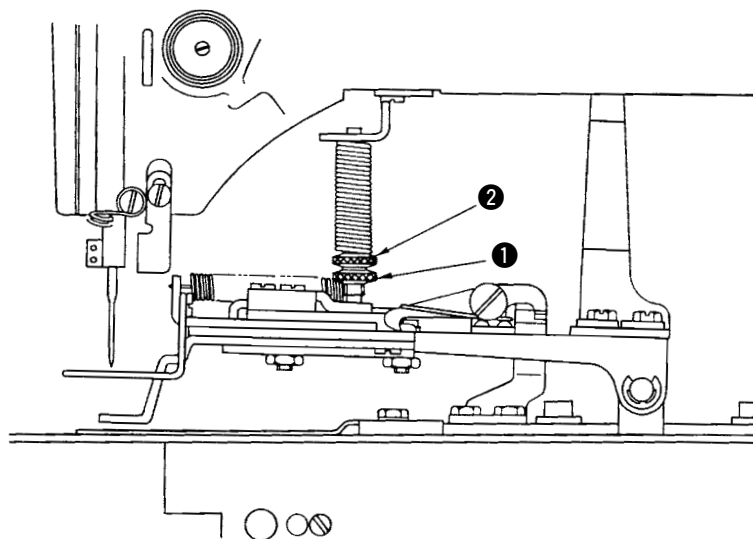

- 1) The pressure of the work clamp unit should be minimized as long as the material does not warp during sewing. Loosen adjusting screw ❶ and turn adjusting screw ❷ to obtain the aforementioned pressure.

6. Setting of the material closing operation

- 1) The material closing operation is performed by the electromagnetic solenoid, and change-over of the operation setting (effective / ineffective) is available. The material closing has been set to work simultaneously with sewing at the time of delivery.
- 2) If the material closing is not performed, the change-over is made by the memory switch. For the way of operation, refer to item “ I .[8]. How to use the memory switch” p.38 described in the instruction manual for the LK-1900AN.

◎ List of memory switch functions

No.	Function	Setting range	State at time of delivery
50	Setting of material closing operation	0 : Ineffective 1 : Synchronized with work clamp foot 2 : Synchronized with start	2

- ※ Setting range “1” : The material closing simultaneously works when the work clamp foot comes down.
- Setting range “2” : The material closing simultaneously works with the sewing after the work clamp foot has come down.

- ※ As for the contents of memory switch function Nos. other than memory switch No. 50, refer to the “ I .[8]-3. Table of functions of the memory switch” p.42 described in the Instruction Manual for the LK-1900AN.

7. Selection and confirmation of the sewing patterns



WARNING :

In case of using an exclusive work clamp foot, make sure of the shape of the sewing pattern. If the sewing pattern extends outside the work clamp foot, the needle interferes with the work clamp foot during sewing, resulting in the danger of the needle breakage or the like.

- 1) The patterns for eyelet buttonhole bartacking are from No. 11 to No. 13.
- 2) When the material closing operation is performed, the maximum sewing size is 3x7mm. Set the most appropriate size using the enlargement/reduction function. As for the way of operation for setting, checking or changing the sewing pattern, refer to the item “**I .[5] OPERATION OF THE SEWING MACHINE (BASIC)**” p.17 described in the instruction material for the LK-1900AN.



After setting, check the needle entry point whether or not the needle interferes with the work clamp foot.

Pattern No.	Sewing size (mm)		Number of stitches
	Lengthwise	Crosswise	
11	2.5	6	21
12	2.5	6	28
13	2.5	6	36

Sewing size is the dimension when the enlargement rate is 100%.

III. EXPLANATION OF THE LK-1902AN, COMPUTER-CONTROLLED HIGH-SPEED BELT-LOOP ATTACHING MACHINE

1. Specifications

Different specifications from those of the LK-1900AN only are described.

1	Max. sewing speed	3.000 sti/min
2	Needle	DPx5 #14, #16
3	Lift of the work clamp foot	Max. 17mm
4	Number of standard patterns	6 patterns

2. Installation of the sewing machine and preparation of the operation



DANGER :

Be sure to perform the work with two persons or more when moving the sewing machine.

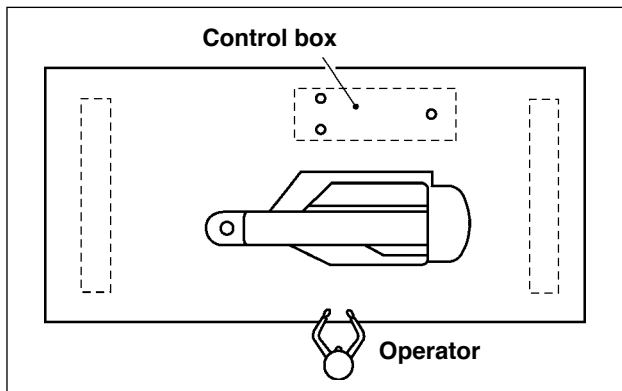

- 1) The standard installing position of the belt-loop attaching machine should be lateral on the table.
- 2) Install the control box the same as the longitudinal installation.
- 3) Use the extension cord packed in the machine head box to connect the control box with the machine head.



WARNING :

Tilt slowly the sewing machine head until it hits against the machine head support bar when tilting the sewing machine head.

3. Threading the machine



WARNING :

Turn OFF the power before starting the work so as to prevent accidents caused by abrupt start of the sewing machine.

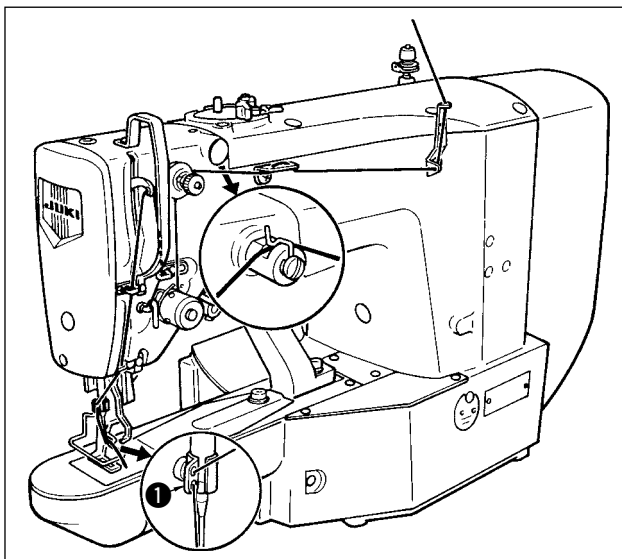

Thread the machine in the order as illustrated in the left figure. Leave thread of approximately 40 mm after passing through the needle.



For a thick thread, pass the thread through only one of the two holes in needle bar thread guide ①.

4. Selection and confirmation of the sewing patterns



WARNING :

In case of using an exclusive work clamp foot, make sure of the shape of the sewing pattern. If the sewing pattern extends outside the work clamp foot, the needle interferes with the work clamp foot during sewing, resulting in the danger of the needle breakage or the like.

1) The patterns for the belt-loop attaching are from No. 17 to No. 22.

As for the way of operation for setting, checking or changing the sewing pattern, refer to the item “ I .[5] OPERATION OF THE SEWING MACHINE (BASIC)” p.17 described in the instruction manual for the LK-1900AN.



After setting, make sure of the needle entry point whether or not the needle interferes with the work clamp foot.

* The calling has been set to ineffective at the time of delivery since the needle interferes with the standard work clamp foot which has been provided with the machine. When using this function, use “Setting the pattern data calling effective or ineffective” of the memory switch function to make the calling effective. As for the way of operation for setting, refer to the item “ I .[8] How to use the memory switch” p.38 described in the instruction manual for the LK-1900AN.

Pattern No.	Sewing size (mm)		Number of stitches
	Lengthwise	Crosswise	
17	0	10	21
18	0	10	28
※ 19	0	25	28
※ 20	0	25	36
※ 21	0	25	42
※ 22	0	35	42

Sewing size is the dimension when the enlargement rate is 100%.

5. Combination of the work clamp foot and the feed plate



WARNING :

In case of using an exclusive work clamp foot, make sure of the shape of the sewing pattern. If the sewing pattern extends outside the work clamp foot, the needle interferes with the work clamp foot during sewing, resulting in the danger of the needle breakage or the like.

Make use of the appropriate combination of the work clamp foot and the feed plate in accordance with the sewing conditions. The combination for the standard delivery and the special order is shown in the following table.

Spec	Feed plate	Part No.	Work clamp foot	Part No.
LK-1902AN Standard		13544465		14143002
For large size (Special order part)		13545660		13545504
For extra large size (Special order part)		13547161		13545801
				13547005

IV. EXPLANATION OF THE LK-1903AN, COMPUTER-CONTROLLED HIGH-SPEED LOCKSTITCH BUTTON SEWING MACHINE

1. Specifications

Different specifications from those of the LK-1900AN only are described.

1	Max. sewing speed	2.700 sti/min
2	Needle	DPx17 #14
3	Lift of the work clamp foot	Max. 13mm
4	Number of standard patterns	50 patterns

* The needle thread clamp device is set to prohibition (state of standard delivery) with memory switch No. 35. Refer to “ I .[5]-6. Thread clamp device” p.22.

2. Installation of the sewing machine and preparation of the operation



DANGER :

Be sure to perform the work with two persons or more when moving the sewing machine.

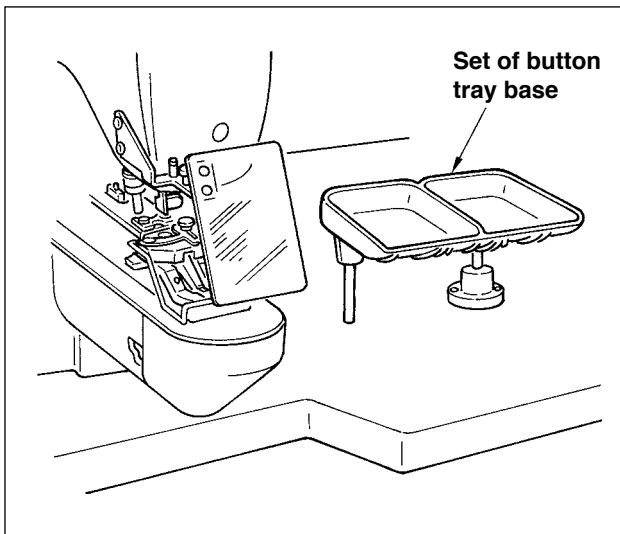

- 1) Installation of the sewing machine head and the control box is the same as that of the LK-1900AN. Refer to the instruction manual for the LK-1900AN.
- 2) Install a set of the button tray base to a convenient place for the work as the set is included in the accessories.
- 3) The way of operation is the same as that of the LK-1900AN.



Make sure before operation that the needle does not strike against the button hole.

3. Needle and thread

Needle	Needle thread	Bobbin thread
DPx17 #14	#60	#80
	#60	#60
	#50	#60
	#40	#60

Needle and thread will vary in accordance with the sewing conditions. When using the needle and the thread, select them referring to the left table. Cotton thread and polyester spun thread are recommended.

4. Various sewing modes

(1) List of sewing patterns

Number of threads and standard sewing size of X and Y are as shown in the following list.

< Sewing program list >

Pattern No.	Stitch shape	Number of threads (thread)	Standard sewing size X (mm)	Standard sewing size Y (mm)	Pattern No.	Stitch shape	Number of threads (thread)	Standard sewing size X (mm)	Standard sewing size Y (mm)
1 • 34		6-6	3.4	3.4	18 • 44		6	3.4	0
2 • 35		8-8			19 • 45		8		
3		10-10			20		10		
4		12-12			21		12		
5 • 36		6-6			22		16		
6 • 37		8-8			23 • 46		6	0	3.4
7		10-10			24		10		
8		12-12			25		12		
9 • 38		6-6			26 • 47		6-6	3.4	3.4
10 • 39		8-8			27		10-10		
11		10-10			28 • 48		6-6		
12 • 40		6-6			29		10-10		
13 • 41		8-8			30 • 49		5-5-5	3.0	2.5
14		10-10			31		8-8-8		
15 • 42		6-6			32 • 50		5-5-5		
16 • 43		8-8			33		8-8-8		
17		10-10							

* The standard sewing sizes of X and Y are when the enlargement / reduction rate is 100%.
Use the pattern No. 34 to No.50 when the button hole is small (ø1.5 mm or less).

(2) Selection of the sewing pattern and the sewing width

- Selection of the sewing pattern is the same as that of the LK-1900AN.
- When the distance between holes of the button used does not fit the standard sewing width of the sewing pattern No., adjust the sewing width by enlarging/reducing the sewing width.
The way of enlarging/reducing is the same as that of the LK-1900AN. Refer to the table given below for the scale for enlargement/reduction in terms of the sewing width.
- After changing the sewing pattern No. and the sewing width, make sure of the needle entry point.
As for the way of confirmation, refer to the " I .[5]-2. Checking the contour of a sewing pattern" p.19 in the instruction manual for the LK-1900AN.

◎ Table of XY scale in terms of the sewing width

X·Y (mm)	2.4	2.6	2.8	3.0	3.2	3.4	3.6	4.0	4.3	4.5	4.7	5.2	5.6	6.0	6.2	6.4
%	71	76	82	88	94	100	106	118	126	132	138	153	165	176	182	188

5. Position of the button clamp jaw lever



WARNING :

When change of the shape of button, change of the sewing pattern or enlargement/reduction of the sewing width is performed, make sure the needle entry point. If the needle extends outside the button hole or the sewing pattern extends outside the button clamp unit, the needle interferes with the button hole or the button clamp unit, resulting in the danger of the needle breakage or the like.

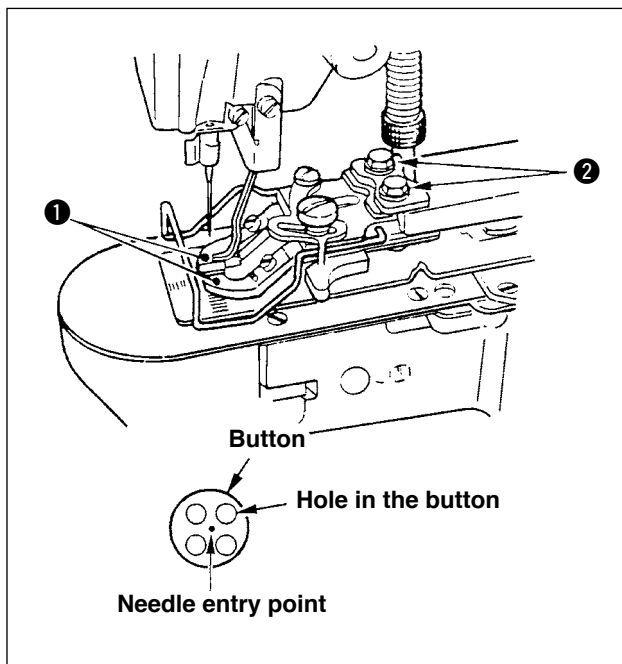

- 1) Press **M** key in the state that the swing LED goes off using the operation panel.
- 2) Press **[P1]** key. → **[L 0]**
- 3) Press **[U]** key. The button clamp unit goes to the origin position and goes up.
- 4) Place a button in button clamp jaw levers **①**.
- 5) Depress the pedal to the first step and detach your foot from the pedal when the button clamp unit comes down.
- 6) Turn the hand pulley and check that the center of the needle enters the center of the button.
- 7) If the center of the needle is not located in the center of the button, loosen screws **②** in the button clamp jaw lever base to adjust so that the center of the needle enters the center of the button.
- 8) When depressing the pedal to the second step at step 5), the button clamp unit moves again to the origin position. In addition, when the button clamp unit comes down, depress the pedal to the first step and detach the foot from the pedal. Then the button clamp unit goes up.
- 9) After the adjustment, perform the confirmation of the pattern shape and make sure that the needle surely has entered the button hole.

6. Adjusting the feed plate



WARNING :

When change of the shape of the button, change of the sewing pattern or enlargement/reduction of the sewing width is performed, make sure of the shape of the sewing pattern. If the feed plate interferes with the needle hole guide, it will result in the danger of the needle breakage or the like. Also, if the pedal is depressed during the adjustment, the button clamp unit will go up or come down. So, be careful.

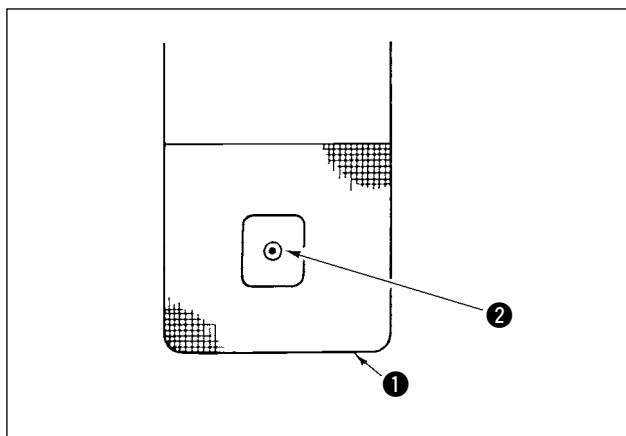

- 1) Press **[M]** key in the state that the swing LED goes off using the operation panel.
- 2) Press **[P1]** key. → **[L][0][J]**
- 3) Press **[U]** key. The button clamp unit goes to the origin position and goes up.
- 4) Adjust feed plate **1** so that needle hole guide **2** comes to the center of the recessed part of feed plate **1**.

7. Adjusting the button clamp jaw lever



WARNING :

Turn OFF the power before starting the work so as to prevent accidents caused by abrupt start of the sewing machine.

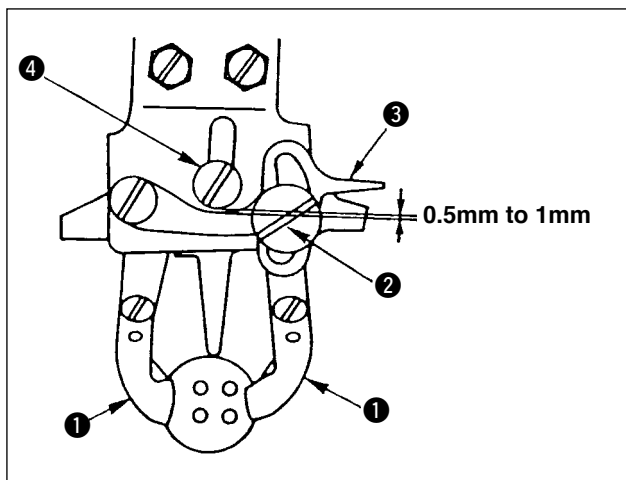

Bring the machine to its stop-motion state. Then lift button clamp **1**. Loosen screw **2** in the button clamp jaw lever and adjust so that a clearance of 0.5 to 1 mm is provided between button clamp jaw lever **3** and hinge screw **4** when placing a button in between button clamps **1**. Then tighten screw **2** in the button clamp jaw lever.

8. Adjusting the lifting amount of the button clamp



WARNING :

Turn OFF the power before starting the work so as to prevent accidents caused by abrupt start of the sewing machine.

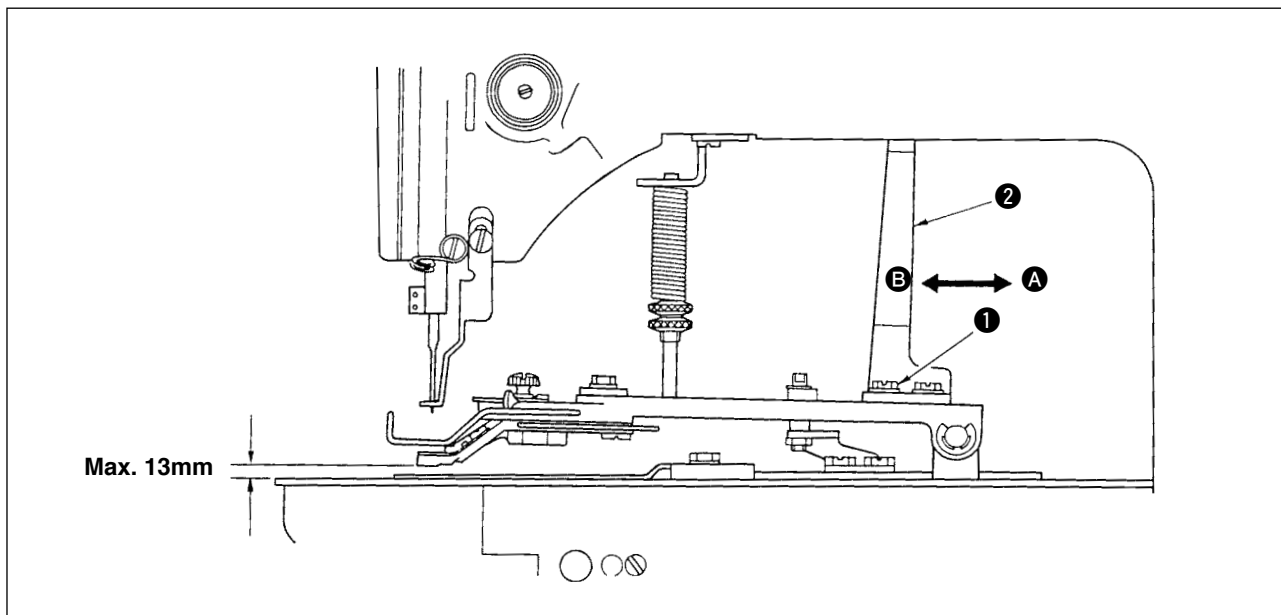

Loosen two setscrews ①, and move moving plate ② back and forth in the direction of arrow to adjust. The lifting amount of the button clamp will be decreased when moving plate ② is moved in the direction of A, and be increased when it is moved in the direction of B. After the adjustment, securely tighten setscrews ①.

9. Adjustment of the pressure of the work clamp unit



WARNING :

Turn OFF the power before starting the work so as to prevent accidents caused by abrupt start of the sewing machine.

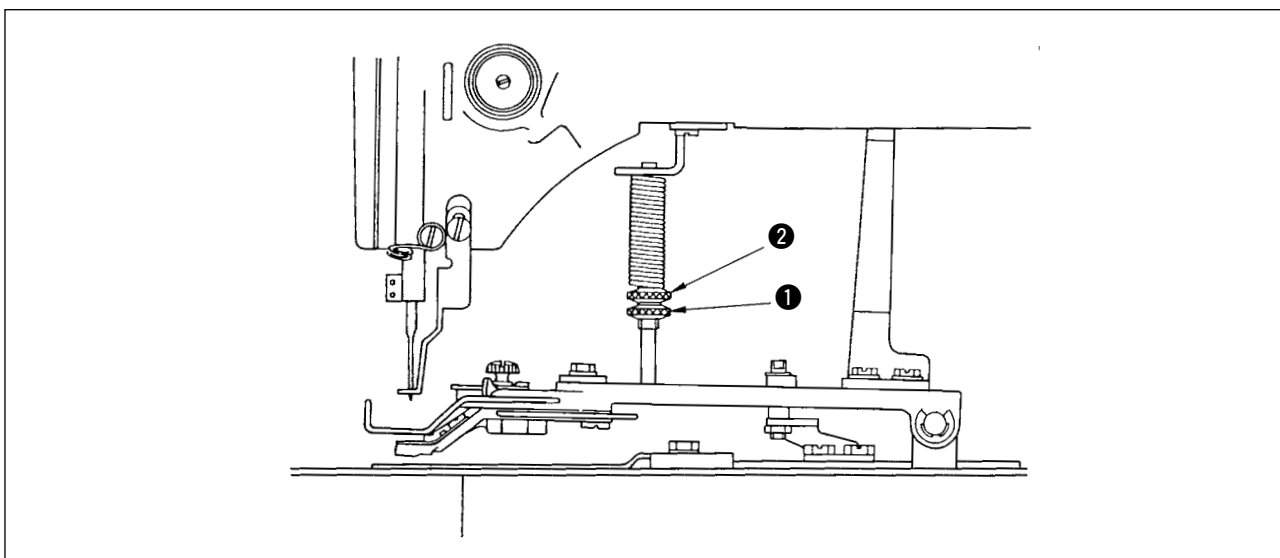

The pressure of the work clamp unit should be minimized as long as the material does not warp during sewing. Loosen adjusting screw ① and turn adjusting screw ② to obtain the aforementioned pressure.

10. Adjustment of the wiper spring



WARNING :

Turn OFF the power before starting the work so as to prevent accidents caused by abrupt start of the sewing machine.

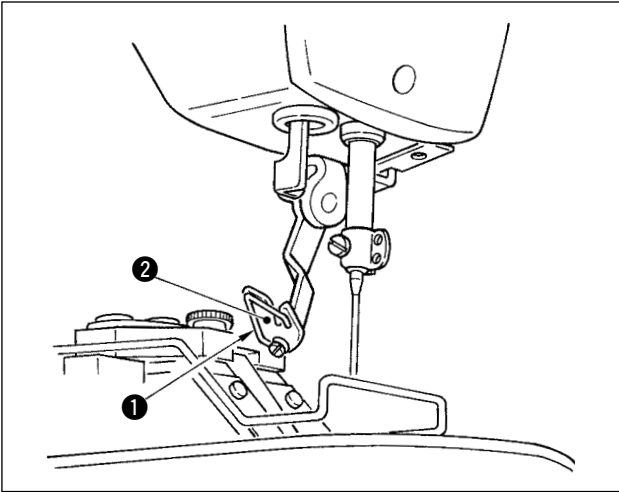

Wiper spring ① retains the needle thread after thread trimming in between wiper ② and the wiper spring. Correct properly the tension of wiper spring ① so that the tension at that time becomes 0.2 to 0.3N (a little higher tension than that of the bobbin thread coming out of the bobbin case).



If the retaining of the needle thread is excessive, the thread may protrude from the upper side of the button.

11. Installing the save button bar (accessory part)



WARNING :

Turn OFF the power before starting the work so as to prevent accidents caused by abrupt start of the sewing machine.

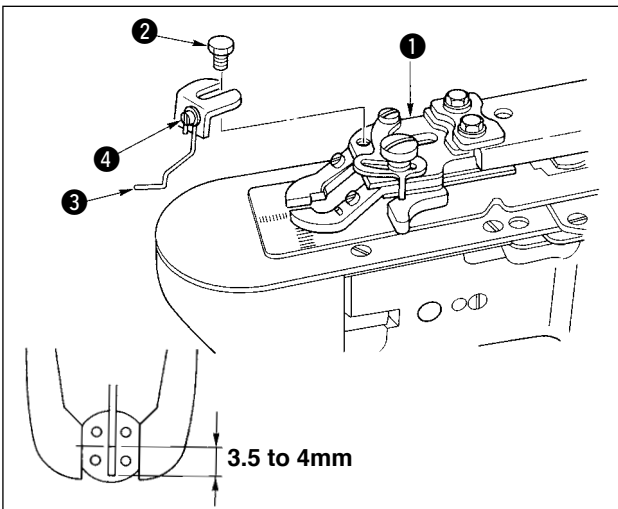

- 1) Install save button bar ③ on button clamp base ① with hexagon screw ②.
- 2) Adjust so that a clearance of 3.5 to 4 mm is provided between the center of the button and the top end of the save button bar.
- 3) To adjust the raising amount of the save button bar, loosen screw ④, and move the save button bar up or down.

12. Model classification according to the button size

Model		LK-1903AN-301	LK-1903AN-302
Button size classification		For small-sized buttons	For medium-sized button
Outside diameter of applicable buttons (mm)		ø10 to ø20	ø10 to ø20
Sewing size (mm)	Length	0 to 3.5	0 to 4.5
	Width	0 to 3.5	0 to 4.5
Button clamp jaw lever	Thickness (mm)		2.2 (2.7) ※
	Part No.	Right	MAZ155070B0 B
			(MAZ156070B0) C
		Left	MAZ155080B0 B
			(MAZ156080B0) C
	Needle hole guide		MAZ15501000
Feed plate		MAZ15502000	

The part in parentheses are those to be specially ordered.

※ Engraved marker

13. Attaching the shank button (optional)

(1) Specifications

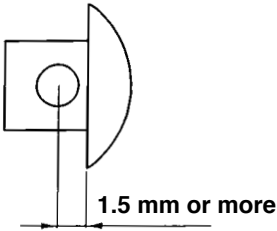
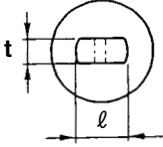
Model	Optional														
Needle	TQx3 #14														
Shape of button	Outside diameter	Max. $\phi 20$													
	Diameter of hole	Min. $\phi 1.5$													
	Position of hole														
Shape of shank section	 <table border="1" data-bbox="1011 958 1391 1155"> <thead> <tr> <th rowspan="2">t</th> <th colspan="2">l (mm)</th> </tr> <tr> <th>Minimum</th> <th>Maximum</th> </tr> </thead> <tbody> <tr> <td>1</td> <td>4</td> <td>9</td> </tr> <tr> <td>3</td> <td>3</td> <td>8</td> </tr> <tr> <td>5</td> <td>–</td> <td>7</td> </tr> </tbody> </table> <p>As for the dimensions of the shape of shank section, refer to the above table for reference.</p>	t	l (mm)		Minimum	Maximum	1	4	9	3	3	8	5	–	7
t	l (mm)														
	Minimum	Maximum													
1	4	9													
3	3	8													
5	–	7													
Sewing speed	Max. speed of the pattern data is limited to 2,700 sti/min. However, set it to 1,500 sti/min for the shank button.														
Stitch shape	Sewing pattern program No.18 to No.22 (Refer to " IV.[4]. Various sewing modes <Sewing program list> " p.66.)														

(2) Adjusting the height of the needle bar



WARNING :

Turn OFF the power before starting the work so as to prevent accidents caused by abrupt start of the sewing machine.

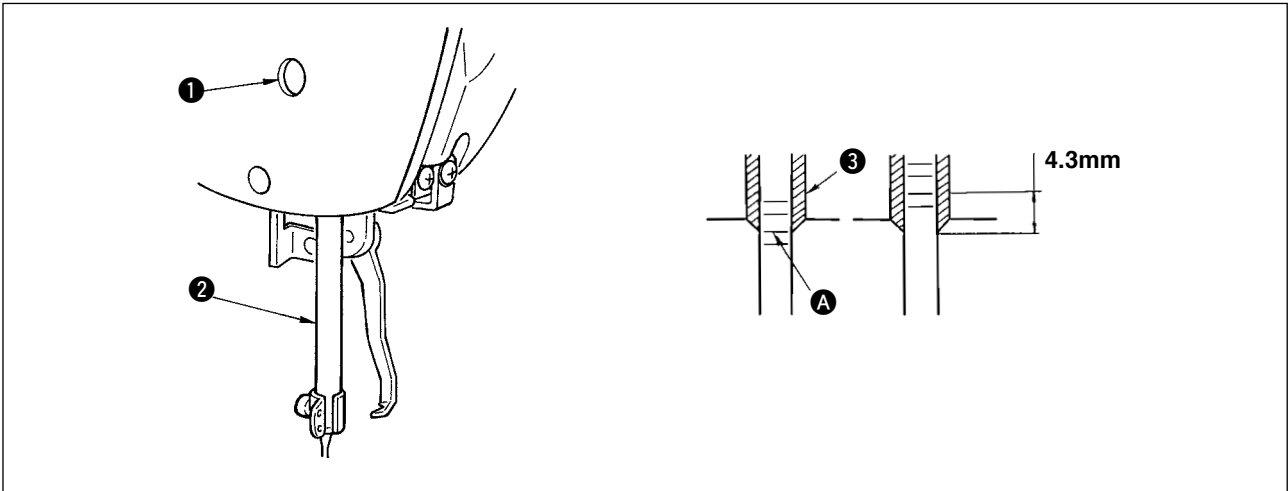

- 1) Loosen needle bar connection screw ① and move the needle bar ② up or down so that second engraved marker line A as counted from the bottom is aligned with the bottom end of needlebar bushing ③ when turning the hand pulley to bring the needle bar to its lowest position. Then further raise only the needle bar by 4.3mm, and tighten needle bar connection screw ① .
- 2) Attach the needle (TQx3 #14).

(3) Adjusting the feed plate base



WARNING :

Turn OFF the power before starting the work so as to prevent accidents caused by abrupt start of the sewing machine.

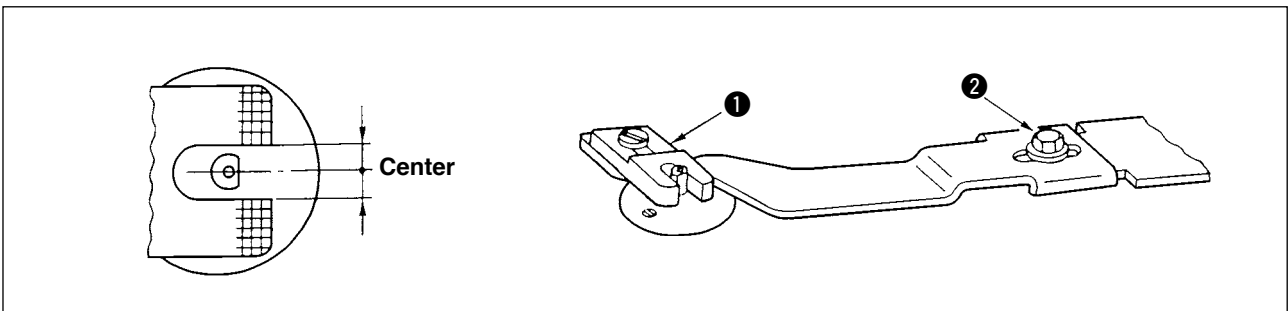

Adjust so that the slot of feed plate ① becomes the center of the boss section of the needle hole guide, and tighten setscrew ② .



When the sewing state between the button and the material is loose, replace feed plate ① with the feed plate B to obtain a stronger sewing state. At this time, however, the outside diameter of the button is limited to max. $\phi 19$. So, be careful.

(4) Adjusting the button clamp support



WARNING :

Turn OFF the power before starting the work so as to prevent accidents caused by abrupt start of the sewing machine.

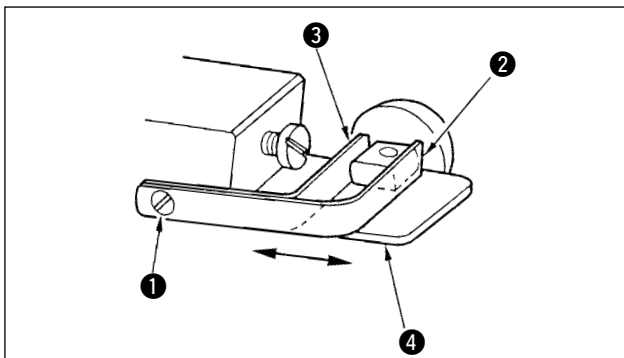

Loosen setscrew ①, and place the button to be used in between the button clamps. Then determine the longitudinal position of the button hole and the slot of button clamp base ④ by moving button clamp support, front ② and rear ③ back and forth. Then securely tighten the setscrew. At this time, if the clearance between button clamp support, front ② and rear ③ is a little smaller (approx. 0.5mm) than the outside diameter of the button to be placed, the button is securely clamped.

(5) Checking the needle entry point



WARNING :

Turn OFF the power before starting the work so as to prevent accidents caused by abrupt start of the sewing machine.

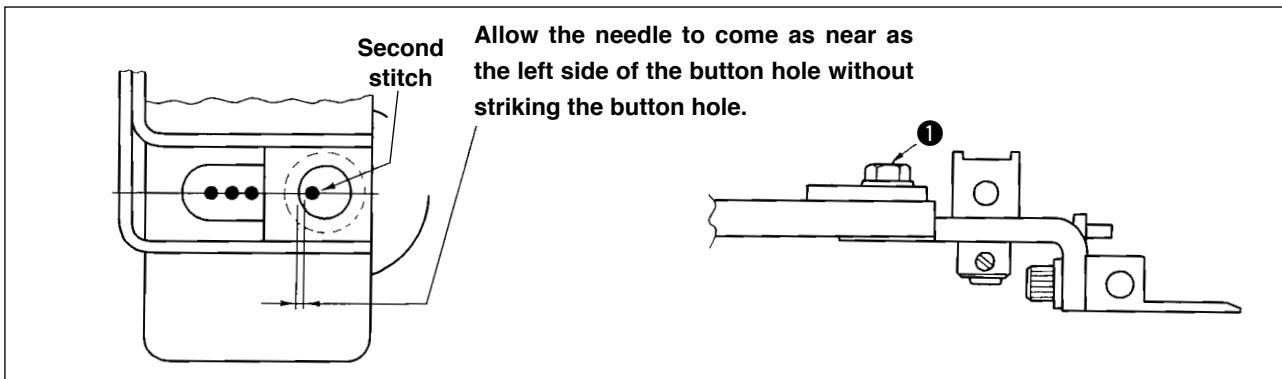

Allow the needle to come as near as the left side of the button hole without striking the button hole.

When checking the shape of the sewing pattern, fit the second stitch of the needle entry to the button hole, and tighten screw ①. (Refer to the item of checking the shape of the sewing pattern in the instruction manual for the LK-1900AN.)

(6) Adjusting the button clamp base and the feed plate



WARNING :

Turn OFF the power before starting the work so as to prevent accidents caused by abrupt start of the sewing machine.

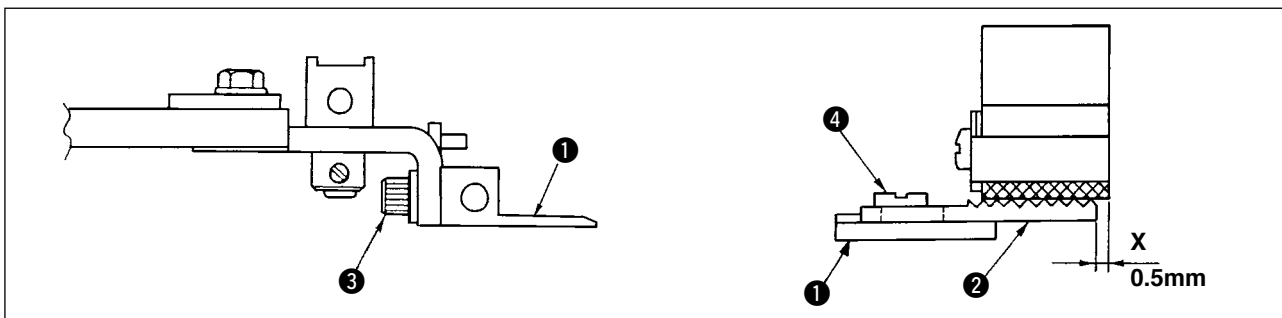

- 1) As for the attaching height of button clamp base ①, adjust the vertical position so that the bottom face of the button clamp base and the top face (knurl face) of feed plate A ② can equally press the material. Then tighten setscrew ③.
- 2) Adjust the position X (protrusion of the material), position of feed plate A ② against button clamp base ①, according to the thickness of the material using setscrew ④. The standard adjustment value is 0.5 mm.

(7) Adjusting the button support rubber



WARNING :

Turn OFF the power before starting the work so as to prevent accidents caused by abrupt start of the sewing machine.

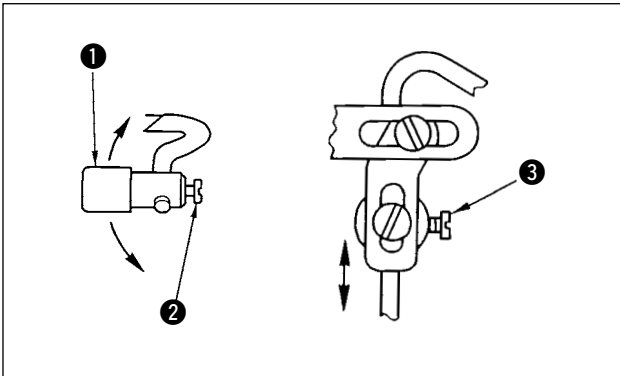

To adjust the position of button support rubber asm. ①, loosen setscrews ② and ③, and adjust so that the pressing section of the button support rubber can press the center of the button at right angles to the button. Then tighten the setscrews.

(8) Adjusting the button support link



WARNING :

Turn OFF the power before starting the work so as to prevent accidents caused by abrupt start of the sewing machine.

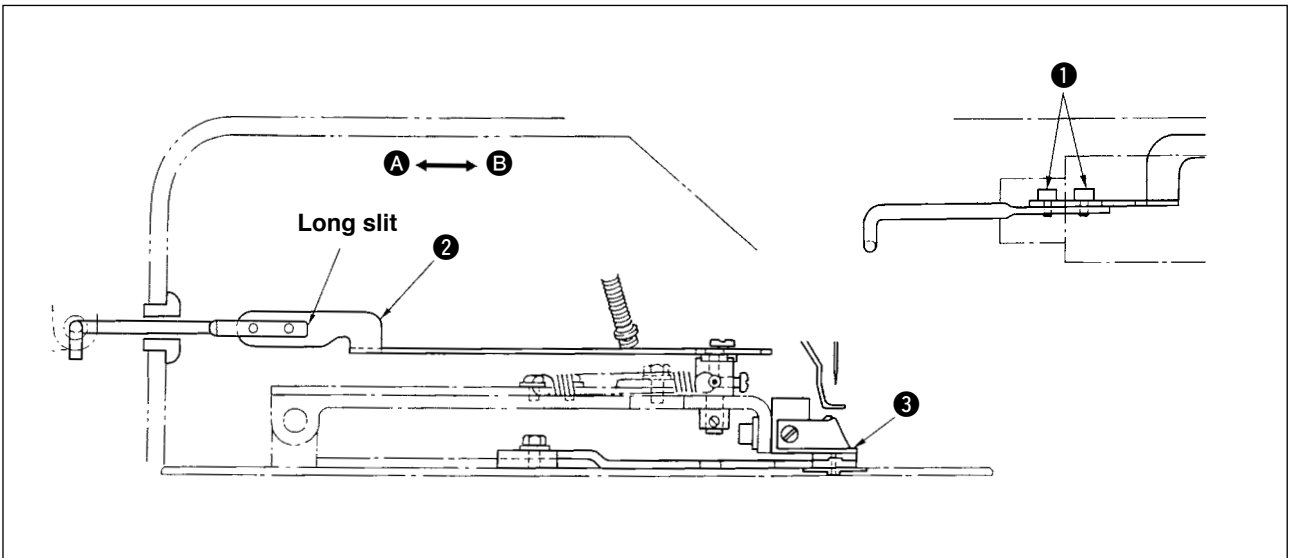

Loosen screw ①, and move button support link ② in the direction A to make early the opening of the button support rubber when button clamp attaching base ③ goes up. Move it in the direction B to retard the opening of the button support rubber. The standard adjustment is to adjust so that the button support rubber starts opening when button clamp attaching base ③ has gone up by 1 mm.

V. DRAWING OF THE TABLE

(1) Longitudinal installation type table (Part No. 40006886)

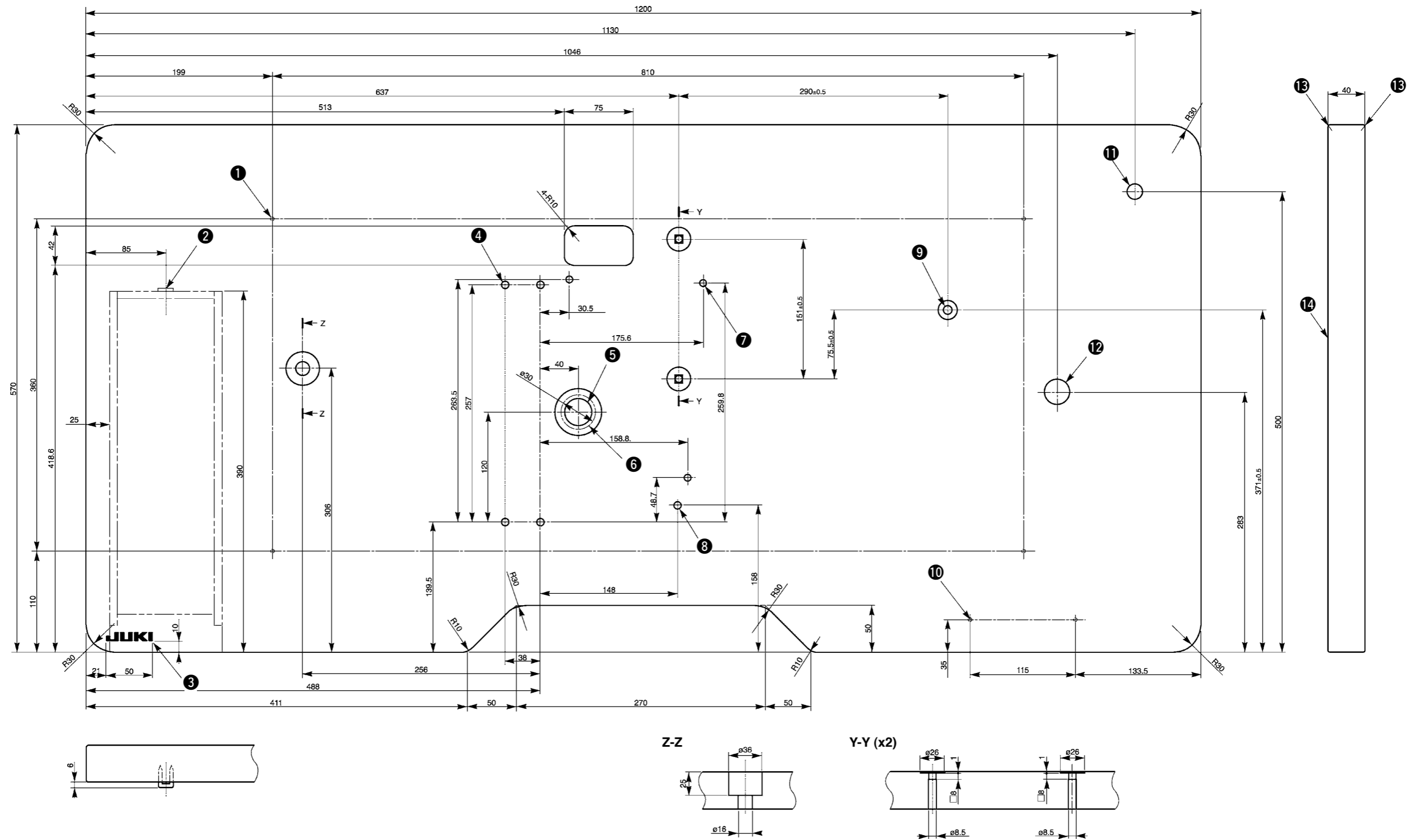

- ① 4- drilled hole 2, 10 deep on the rear side (Stand installing hole)
- ② Drawer stopper installing position One place on the rear side
- ③ JUKI logotype
- ④ 4- drilled hole 8
- ⑤ Drilled hole 30, 51 spot face 16 deep
- ⑥ Oil drain funnel installing hole
- ⑦ 3- drilled hole 7, 6 deep

- ⑧ Drilled hole 8
- ⑨ Drilled hole 9, 20 spot face 17 deep
- ⑩ 2- drilled hole 2, 10 deep on the rear side (Power switch installing hole)
- ⑪ Drilled hole 17
- ⑫ Drilled hole 28
- ⑬ R2 (all corners)
- ⑭ Right side

(2) Lateral installation type table (Part No. 40006887)

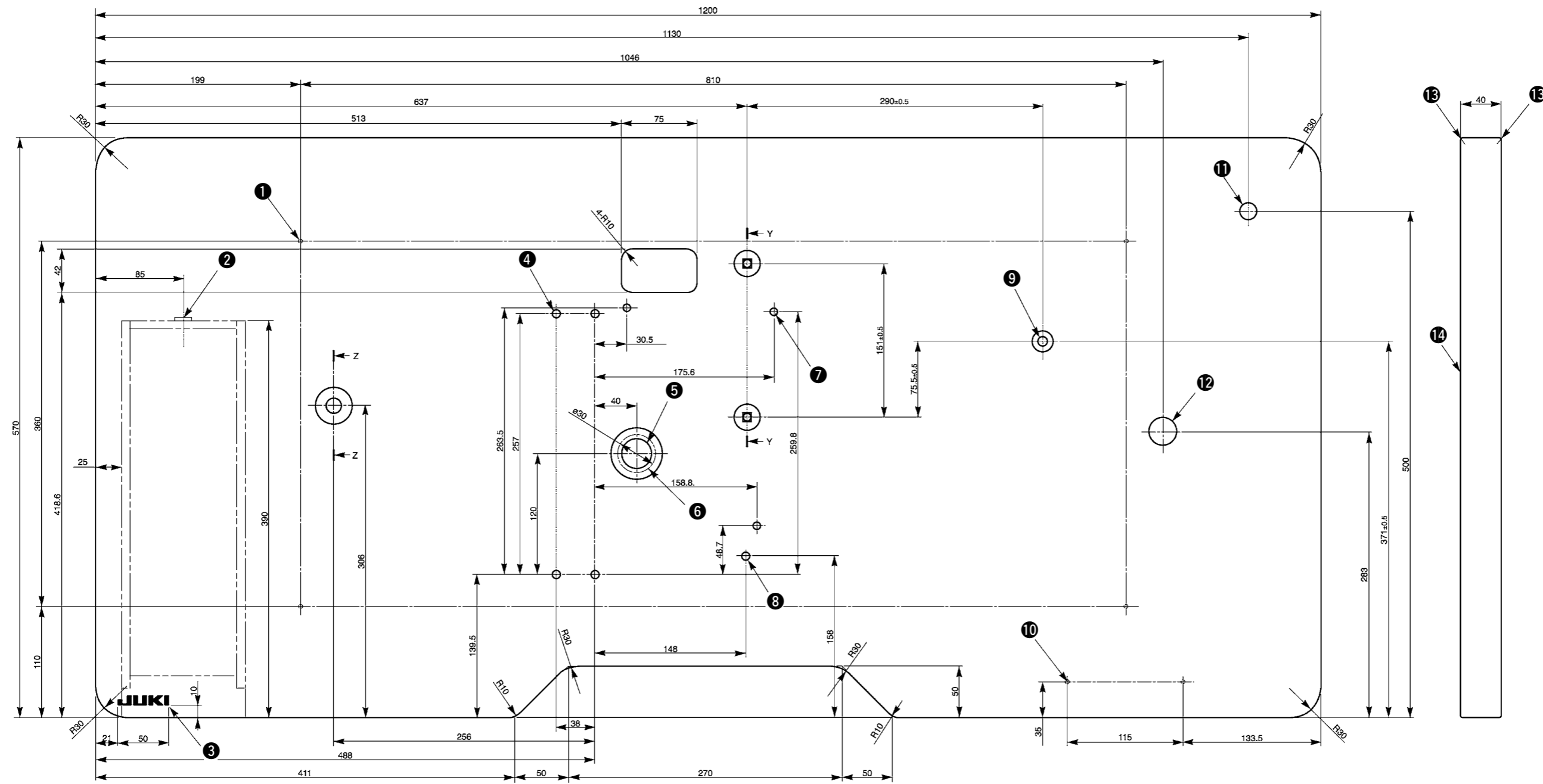

- ① 4- drilled hole 2, 10 deep on the rear side (Stand installing hole)
- ② Drawer stopper installing position One place on the rear side
- ③ JUKI logotype
- ④ Drilled hole 8
- ⑤ Drilled hole 9, 20 spot face 17 deep
- ⑥ 4- drilled hole 8
- ⑦ Drilled hole 30, 51 spot face 16 deep
- ⑧ Oil drain funnel installing hole
- ⑨ 3- drilled hole 7, 6 deep
- ⑩ Drilled hole 17
- ⑪ Drilled hole 28
- ⑫ 2- drilled hole 2, 10 deep on the rear side (Power switch installing hole)
- ⑬ R2 (all corners)
- ⑭ Right side

