



800-401-8151 713 CENTER DR. SAN MARCOS, CA 92069

Long Arm Quilter



© 2013 Printed in the United States
First Print Dec 2013

Table of Contents

Warranty	5
Diagram showing the sides of the machine	6
Your Thread Stand	7
Attaching the Handlebars	8
Attaching Belt Guard	9
Replacing Fuse	9
Connecting your Long Arm Quilter to your carriage assembly (deck)	10
General Operation of the LCD Key Pad	11
What is the Tension Release Lever?	14
How Do I Adjust the Height of the Hopping Foot?	15
Adjusting the Stroke of the hopping foot	15

Routine Cleaning and Oiling	16
Bobbin Winder and Bobbins.....	17
Threading Overview	19
Threading your Long Arm Quilter.....	19
How Do I Change the Needle?	21
How Do I Make Adjustments to Make the Perfect Stitch?.....	22
Tension, Tension, Tension.....	23
Trouble Shooting Checklist	
Check spring replacement / Tension Knob	25
Machine will not sew, I can not turn the hand wheel (Jammed).....	27
Timing your Machine.....	28
Adjusting the bobbin winder	30
Adjusting the tension assemble thread guides for proper fill.....	30
Adjusting bobbin winder for contract with the upper shaft	31

Warranty

We believe that we have designed and are manufacturing the best long arm quilting machine available. **As you unpack your machine be sure to keep the box and packing materials designed to protect the machine during shipping. Should it become necessary for you to return the machine for warranty work please call us for specific instructions for packing and shipping your machine.**

- Your Long Arm Quilter has a full labor warranty for one year from the day you receive your machine. We guarantee the machine parts for five years.

- The machine must be cleaned and oiled regularly according to the instructions in this manual. Failure to properly maintain the machine will void this warranty.

- Your Long Arm Quilter must be plugged into a surge protected electrical outlet. We highly recommend using an Uninterrupted Power Supply (UPS) also known as a Battery Backup. This helps to ensure that you are getting a regulated 110 volts into your machine. See photo below of UPS Battery Backup.

- Should we mutually decide that your machine cannot be repaired using normal communications we will arrange for machine to be returned to the factory.

Should you have a Problem

Please contact your selling dealership they are your servicing dealership.

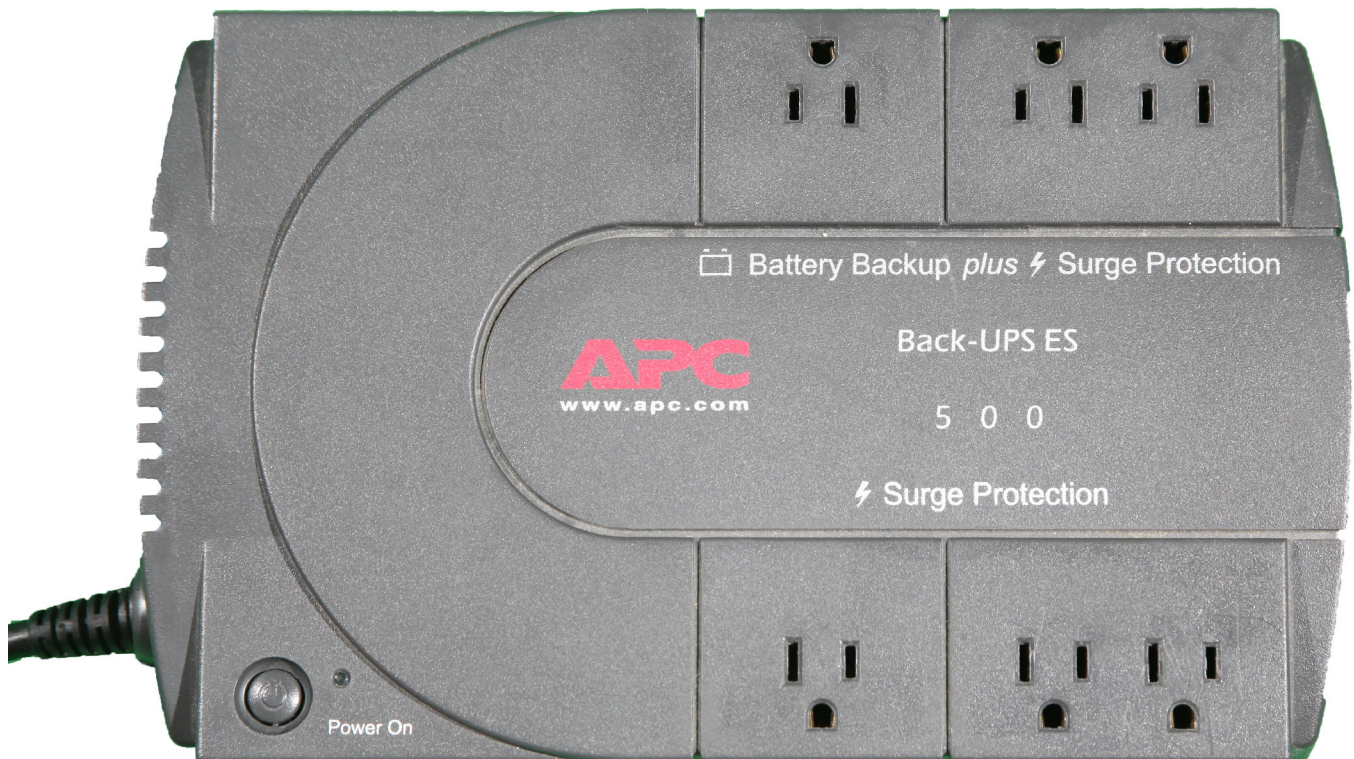

Diagram Showing the sides of the machine

Backside of handlebars showing where to connect cables



Thread stand side of machine/motor side

Back

Showing the machine looking at the threading side of the machine.

Front of Machine

Threading side of machine

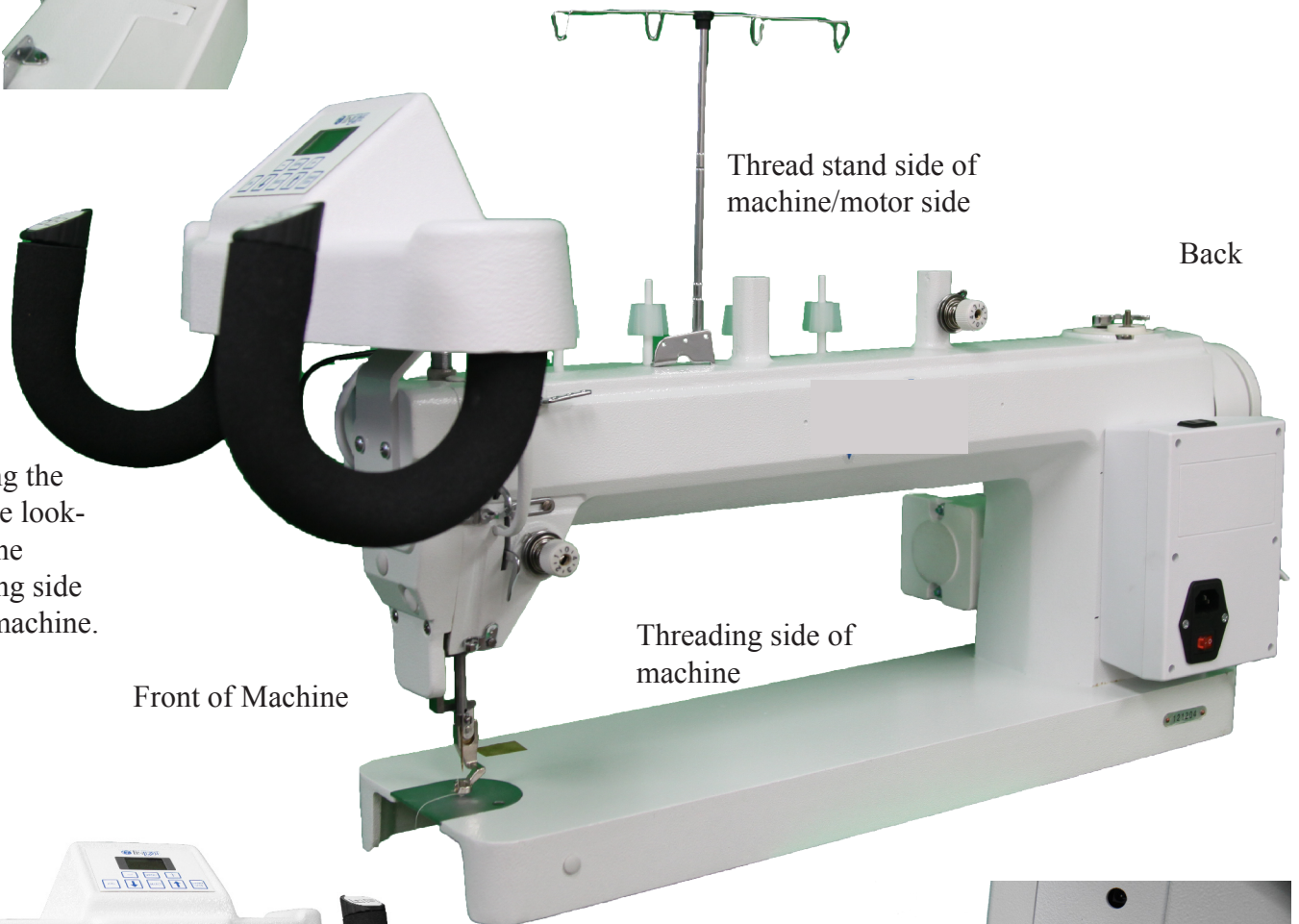

Backside of main power supply where the encoders and handlebars connect

Looking at the handlebars and the front of the machine.



Your Thread Stand

Your Long Arm Quilter comes with a four spool thread stand. This thread stand is connected to the side of your machine and can hold bobbin thread you are using to wind onto your bobbins and the top thread you are using to quilt. You can also have a second spool of thread on the stand if you are using two different threads on your quilt. This 4 spool thread stand has a telescoping thread holder which needs to be all the way up when you are quilting to help the thread come off the spool evenly and smoothly.

Step 1: If the telescoping thread tree is not on the thread stand then you will need to attach it.

Step 2: Slide the telescoping thread tree into the hole provided between the tread holders.

Step 3: Using the supplied screw with washer insert from the bottom side to secure the telescoping thread tree in place.

Step 4: On the left side of your machine (the left side of the machine is the side with the motor) you will see two screws not holding anything on yet.

Step 5: Loosen these two screws. You don't need to take them out but they do need to be loose so that you can slide the thread stand over them.

Step 6: On the thread stand you will see two holes on the underside which can be placed over the two screws and then drop into place.

Step 7: Once you have the thread stand in place over the two screws tighten the screws to hold the thread stand in place.

Remember to pull the telescoping thread tree to the full up position to use.

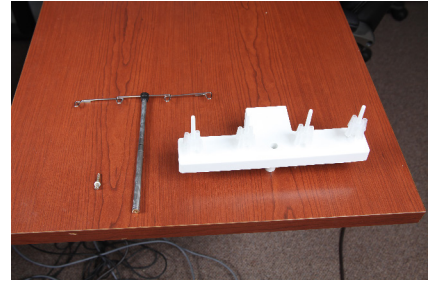

Figure 1



Figure 2



Figure 3

Attaching the handlebar

Your Long Arm Quilter comes with RAM style set of handlebars which will need to be attached to the front of the machine. These handlebars house the lights and electronic controls for operating this machine. You have the main control panel in the center of the handlebar and then on the end of each of the RAM horn handles you have some softtouch key pads. These softtouch keys are for start/stop, increasing speed or stitches per inch, needle rotation, and decreasing speed or stitches per inch.

Step 1: Locate your set of handlebars

Step 2: Remove the 4 screws located on the front of the machine above the needle.

Step 3: Position the Handlebars in front of where you just removed the screws.

Step 4: Using the screws you removed from the front of the machine install them to hold the handlebar in place.

Step 5: Make sure all 4 screws are secure to hold the handlebar securely to the machine.

Once you have the handlebars attached to the machine you will need to connect the wires to the machine so that you have a connection with the power supply for the lights and the main controller board to control the machine.

Step 1: Locate the two cables which are hanging out of the protection shield on the thread stand/motor side of the machine.

Step 2: Connect the round power cord to the power connection on the back of the handlebars. Port on the far left

Step 3: Connect the RJ50 to the port on the back side of the handlebars. Connect this cable to the port on the far right side.

Your handlebars are now attached to the machine and connected to the power and main control board of the machine.

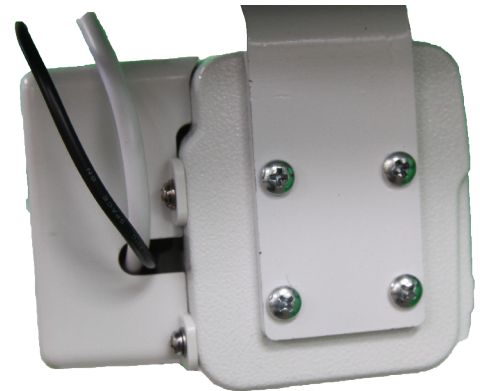

Figure 4

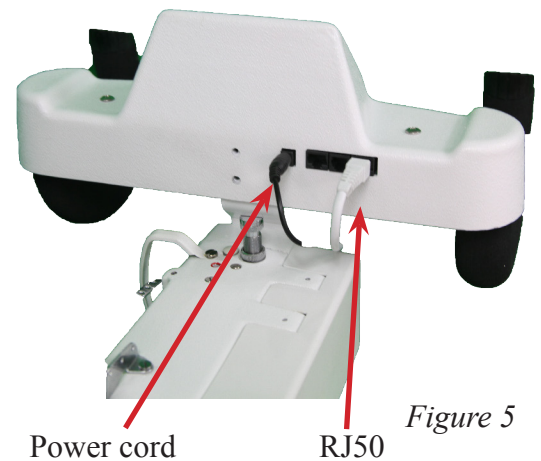

Figure 5



Figure 6

Attaching the Belt Guard

The Belt Guard can be found in the box the machine came in. This belt guard covers the motor pulley, hand wheel, and the belt to keep things from getting caught in the belt or damaging the motor sensor disk. The three screws required to attach the belt guard are located in the machine in the holes where the belt guard is positioned.

Step 1: Remove the three (3) screws with washers (A) *See figure 7*

Step 2: Place the Belt Guard (B) over the hand wheel and cover the motor pulley

Step 3: Replace the three (3) screws with washers to hold the belt guard in position. Tighten the screw. *See figure 8*

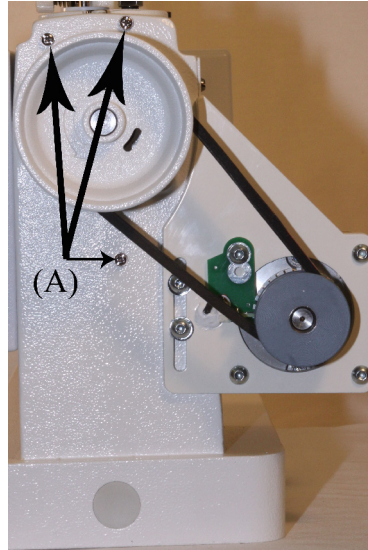

Figure 7

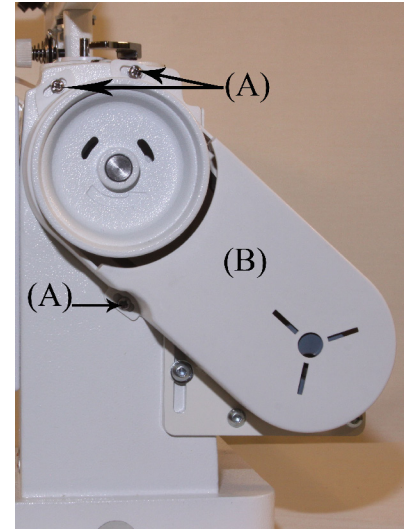

Figure 8

Replacing the Fuse

For protection of the power supply and the electronic the power supply has a fuse. This fuse is a 3 amp fast-acting glass fuse. A suitable replacement fuse can be picked up from your local Radio Shack. The fuse number you want to pick up is Radio Shack number 270-1054.

To Replace this fuse follow these steps

Step 1: Locate the fuse holder by removing the plug from the machine and between where the plug is plugged in and the on/off switch you will see a little rectangle piece with a fuse on it. *See figure 9*

Step 2: Using a small flat tip screw driver gently pop the fuse holder out.

Step 3: A spare fuse is held in the holder if you have used this one then you will need to pick up a fuse. *See figure 10*

Step 4: Remove the bad fuse from the end of the fuse holder.

Step 5: Replace the fuse with a new fuse

Step 6: Reinstall the fuse into the space provided. It should snap into place.

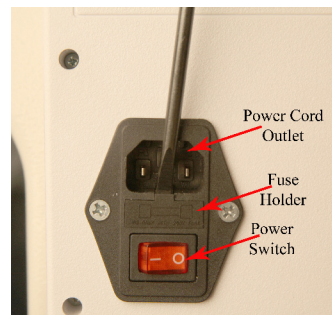

Figure 9

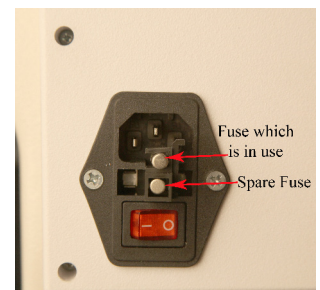

Figure 10

Step 1: Locate the encoders and cables on the carriage. Check them for damage prior to placing the machine onto the carriage. See figure 11

Step 2: Place the rubber mat onto the carriage to help prevent the machine from sliding.

Step 3: Place the machine on the rubber mat on the carriage. Center the machine as best as possible.

Step 4: Locate the upper carriage encoder cable and connect it to the second connection point on the side of the power box. *See figure 12*

Step 5: Locate the lower carriage encoder cable and connect it to the third connection point on the side of the power box. *See figure 12*

This is the cable from the front handlebar.
This cable connects to this top port

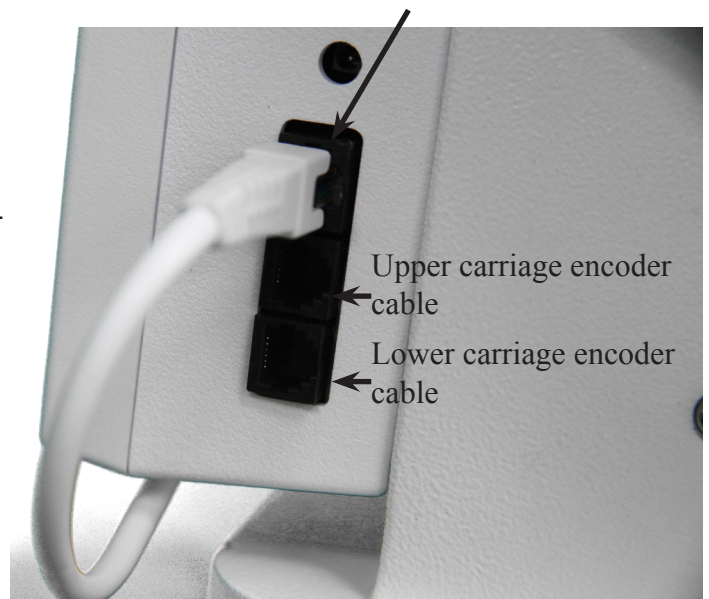

Figure 12

General Operation of the LCD key pad

When you turn on your Long Arm Quilter you will hear one (1) beep and after three (3) seconds you will hear another beep. This lets you know that your machine is ready. The first screen you see will be fig 13. (Opening screen will have version number displayed. This is where the version is displayed for your machine)

The controls keys are as follows:

 This key is for decreasing motor speed, stitch length, and selecting modes in menu.

 This is the key for going to the menu.

 This is the key used to select menu items.

 This key is for increasing motor speed, stitch per inch, and selecting modes in menu

 This key is for putting the needle in the down position.

 This key is for starting the machine and stopping the machine. In fig 14 you can see where it shows Stitch OFF. This button will change it to Stitch ON (Note: Quilting Machine will not stitch if you see the word off next to the stitch.) Machine will turn off if no movement is detected after 12 seconds

 This key is for putting the needle in the up position.

 This key is for moving the needle. When you hold the key down the needle will move.

Auto Stitch (Stitch Regulation)

So you are ready to start quilting. You've turned on your machine and waited for the beeps and you see the screen see Fig 14. At this point if you want to change the Stitches Per Inch (SPI) then you can press and release the (-) key to decrease the number of stitches or you can press and release the (+) key to increase the number of stitches. (Note: If you press and hold the (-) or (+) keys then you will see the bar graph decrease or increase quicker than if you just press and release the (-) or (+) keys) Once you are happy with the Stitches Per Inch (SPI) then you can press and release the Start/Stop key and the LCD will change. You can see on the LCD that next to the Stitch you see the word ON. This means the quilter is ready to quilt and as you move the quilter it will stitch. **You cannot change the stitches per inch if the LCD screen shows ON.**

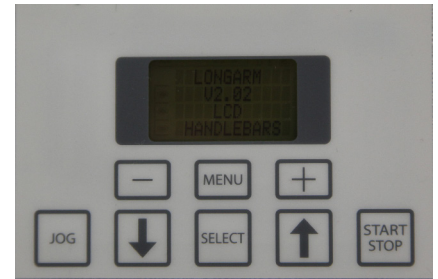

Figure 13



Figure 14

Changing Functions

When you are ready to switch stitching modes you will press the (Menu) key. This will bring up the menu to select from. As you can see in Fig 15 There are three options in the menu.

Stitch: will let you chose between Auto (stitch regulation), constant (manual stitch), Robot, Idle (stitch regulation), Edge (stitch regulation), tie off up, or tie off down.



Figure 15

Lighting is used to control the lights on the handlebar. You can turn them on or off and also adjust the brightness.

Diagnostics: is only used when directed by your technician. To exit diagnostics cycle power



Select indicator dash. To move the select indicator dash on the left side of the screen use the (-) key to go down the list and the (+) key to go up the list. To Select the function press the (enter) key.

Stitch Mode

Once you have pressed the (enter) key you will be able to choose between the Auto (stitch regulation), Constant (manual stitch), Robot (use with robot) (see Fig 16), Idle (stitch regulation no stop), Edge (for use with rulers will stop for a longer period of time.), Tie off up, or Tie off down. (see Fig 16a)

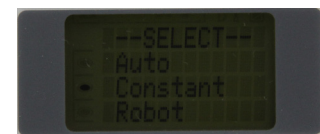

Figure 16

Press the (Enter) key once you have the stitch you would like to use.

If you choose Auto Stitch you will be in the stitch regulation mode of the machine refer back to fig 14 for a look at the LCD when Auto is selected and after the stitch is off in this state you can move the machine and it will not stitch. Once you press the (start/stop) key then the machine becomes active and you can begin stitching when you move the machine. Remember if the machine shows ON and you do not move the machine for 12 seconds it will change to OFF and you will need to press the (start/stop) key again.

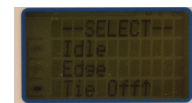

Figure 16a

You will also see a bar graph at the bottom of the LCD with SPI on the right. This is your stitch per inch indicator. You will use the (-) key to decrease the number of Stitches per Inch and use the (+) key to increase the number of stitches per inch. (note: Pressing and holding the (-) or (+) key this bar graph will move more rapidly across the screen.)

Constant Stitch (Manual stitch)

If you choose Constant you will be in the manual stitch mode of the machine. Fig 17 shows the LCD screen for the Constant. You will notice you have the OFF just like in the Auto but you have numbers with percentage at the bottom rather than a bar graph. Same as with the Auto the (start/stop) key will turn the machine on and you will be ready to stitch unlike the Auto once you hit the (start/stop) key the machine will be sewing. Fig 18 shows with the Stitch ON



Figure 17

Like the Auto you can use the (-) or (+) keys to decrease or increase the speed of the machine. Constant does not have a default to turn off once it has been turned on. If you stop moving thread will build up until it runs out of thread or your thread breaks. It will still keep running until you press the (start/stop) key. **You can adjust the motor speed while the LCD screen shows ON**

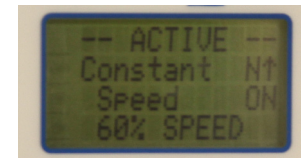

Figure 18

Robot

Robot gives stitch control to the robot. This will let you control the stitching with the Remote control for the Robot. *This only works when using the robot.*

Idle (stitch regulation without stop)

Idle stitch gives you the stitch regulation as Auto once you press and release the start/stop button the machine starts stitching when you come to a stop the needle continues to stitch at a slow speed, This mode allows for ease in and out of corners. Press and release start/stop button and machine will stop.

Edge

Use this stitch mode when working with rulers. See Auto Stitch for operation of this stitch. The only difference between the Edge and Auto is with Auto Stitch when you stop moving for 12 seconds the machine will go off like pressing the start/stop button. Edge Stitch will not stop giving you time to reposition your ruler or template.

Tie off up or Tie off down

These are used in conjunction with the Auto Stitch. With Tie off selected you will be able to start or finish your stitching, With the machine not running press the enter key and it will do 3 stitches to tie off your thread. Up will position the needle in the up position while Down will position the needle in the down position.

Jog

The Job key on the key pad is for moving the needle. The longer you hold this key down the longer it will stitch. If you just tap the Jog key it may not move the needle. You need to press and hold the Jog key for the machine to move the needle.



Figure 19

Lighting Control

By selecting the Lighting you can adjust the lights or turn off the lights.

When the tick is next to Lighting you can press enter. This will bring you to the Light Menu.

With the tick next to the type of light White, UViolet, and laser (not used at this time) you can control that part of the light menu.

When you are next to the white light you can press enter to turn the lights off or on. (depending on what state they are in) When you press the plus key or the minus key you can adjust the brightness up or down.



Figure 20



Figure 20a

What is the Tension Release Lever?

The tension release lever raises the hopping foot and releases the tension on the thread. *See figure 21* You can watch the tension disc plates open as you lift the lever.

NEVER start sewing with the lever up.

There will be no tension on the thread which will result in stitches on the bottom being bad with huge loops and other bad looking stitches.



Figure 21

Adjusting the Height of the Hopping Foot

There are many reasons to adjust the height of the hopping foot. You could be using a thicker batting, quilting a quilt with thicker seams, or just need a little more clearance. You don't want the foot to be too high as that can cause strain on the thread, create flagging of the fabric while stitching, or just be too high if you put a ruler next to it.

To adjust the height of the hopping foot use these steps.

Step 1: Lower the needle into the fabric to get the hopping foot to its lowest position. (close to a seam is a good place then you can tell how high you need to be to clear the seam.)

Step 2: Loosen screw (A) on the side of the hopping foot (B). *See figure 22*

Step 3: Move the foot up or down to adjust for your project.

Step 4: While holding the hopping foot where you want it tighten the screw back down.

Factory setting for this is with needle down a dime should be able to pass below the foot and touch the foot as it passes under. *See figure 23*

Adjusting the Stroke of the hopping foot

Factory setting is in the down position. The reason for less stroke is for better ability working with rulers. Adjustment of stroke is for going over thicker seams.

Step 1: Remove the four (4) screws (A) holding the cover (B) in place front left side of machine. *See figure 24*

Step 2: Using a wrench loosen the bolt (C) on the link adjusting crank (D) slide up to increase the stroke down to decrease the stroke. *See figure 25*

Step 3: Use your wrench to tighten the bolt (C)

Step 4: For your safety replace the cover (B) prior to use. Using the four (4) screws (A)

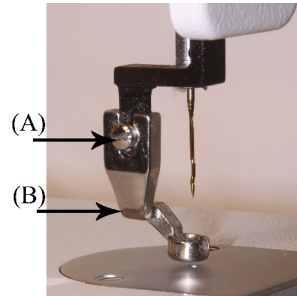

Figure 22



Figure 23

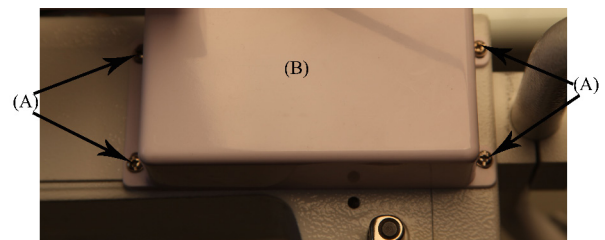

Figure 24

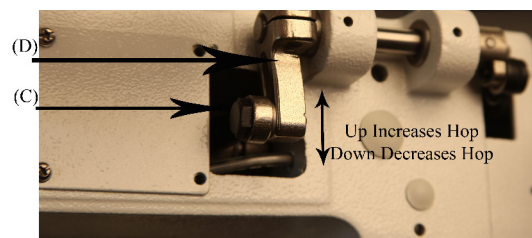

Figure 25

Routine Cleaning and Oiling

Routine cleaning and oiling is very important to the longevity of your quilting machine. Brush out the fuzz from around the hook and foot. Change your needle regularly to avoid thread breakage, tension problems and needle breakage. A worn needle can mean skipped stitches, shredded thread and a weakening of the needle itself. These things can lead to stitch quality issues.

Lint has a tendency to build up in the bobbin case. A tiny amount of lint can cause poor stitches. Check the bobbin case each time you change the bobbin to keep it clean. We suggest using a soft bristle brush to wipe out the bobbin case and the bobbin area. Canned air only blows the lint around. By using a soft bristle brush you collect the dust on the brush. Occasionally, place a drop of machine oil on a cotton swab to wipe out the bobbin case.

Keep your table clean of dust and oil. Clean the bars and carriage deck regularly for smooth movement.

Oiling is extremely important to the longevity of your quilting machine. Failure to oil your machine regularly can void your warranty.

The one oiling spot marked with red arrow is marked with red paint on your machine. An oil bottle is included with your machine. The one oiling spot marked with a blue arrow contains a dip stick. Remove the dip stick by lifting it up with a finger nail or screw driver. Place drops of oil in this same hole if you find no oil on the dip stick.

Recommended oiling:

After every finished quilt place 3 to 4 drops of oil at the location with a red spot towards the front (needle side) of the machine. This is located on the top of the machine. *see figure 26* oil spot on top

The other location is the oil dip stick found just behind the needle. At this time make sure oil is present on dip stick. If not add 3-4 drops of oil where you pulled the dip stick out. Run machine to lubricate use a clear high grade sewing machine oil. (Note: the machine pictured here is before complete assembly from factory; your machine has more components attached.)

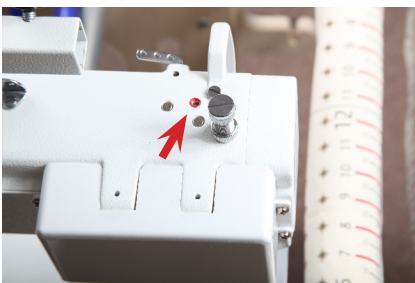

Oil Spot on top *Figure 26*



Oil dip stick lifted *Figure 27*

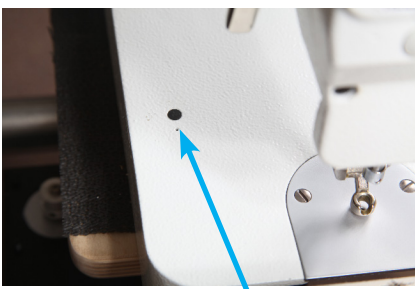

Oil Reservoir location *Figure 28*



Oil Dip stick out *Figure 29*

Bobbin Winder and Bobbins

A bobbin winder is included with your machine. The thread on a properly wound bobbin should be snug and have even layers of thread. A sloppy or mushy wound bobbin will result in poor stitch quality.

How do I wind a Bobbin?

Step 1: Insert an empty bobbin on the bobbin winder spindle.

See figure 30

Step 2: Place a cone of thread on the holder.

Step 3: Bring the thread up through the guide over the cone of thread. *See figure 31*

Step 4: Insert the thread through the top guide hole then around the tension disk and through the bottom thread guide. *See figure 32*

Step 5: Wrap the thread around the bobbin clockwise three or four times

Step 6: Push trip mechanism forward until it snaps into position

See figure 33

Use step 7 if you plan to quilt while your bobbin is winding. or use step 8 if you are winding bobbins without quilting.

Step 7: Bobbin winder will start winding the bobbin once you press the start/stop key. You can quilt while your bobbin is winding once it is full it will stop.

Step 8: If you wind your bobbin only (When not quilting) ensure that you do not have thread in the needle to prevent jams. Also remove the bobbin and bobbin case to prevent damage. Select Constant stitch mode, then press and release the start/stop button. Once the bobbin is full press and release the start/stop button again to stop the machine. **Note: The Needle will continue to move up and down while you are filling the bobbin.**

The bobbin will fill until the trip mechanism is pushed out by the thread. It will then disengage the wheel. The bobbin should fill to just below the rim. Having the bobbin too full will cause tension problems.

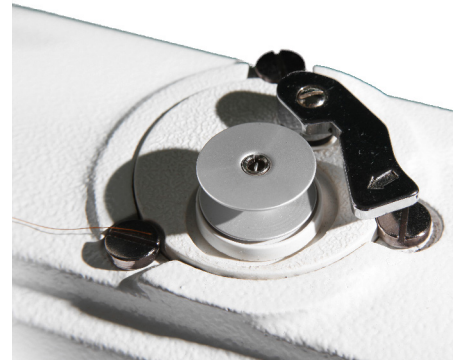

Figure 30

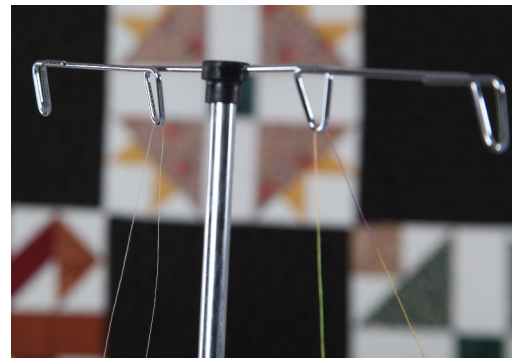

Figure 31

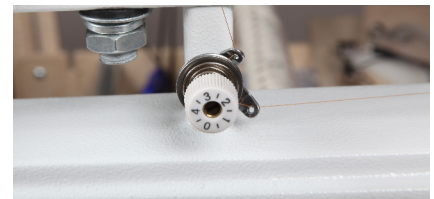

Figure 32



Figure 33

Check the tension of the bobbin by holding the loaded bobbin case in one hand. With one hand under the bobbin case, hold the tail of thread and watch as the thread flows out of the bobbin case. A slight bounce should cause the bobbin case to slide down the thread. If the thread slides out of the case as you pick it up, it needs more tension. If it barely moves down the thread or doesn't move at all, it needs less tension.

See figure 34

To adjust the tension: *See figure 35*

Use a small screwdriver to turn the largest set screw on the bobbin case to adjust tension.

Make very small adjustments.

Be very careful not to remove the screw as it is very small and difficult to find if lost.

Remember, righty (clockwise) tighty, lefty (counter clockwise) loosey.

To place the bobbin into the machine:

Step 1: Insert the bobbin into the bobbin case. It does not matter which way you put the bobbin in but once you have it one way just keep doing it that way.

Step 2: Holding the bobbin case pull the thread through the slot.

Step 3: Draw the thread down and under the spring, making sure the thread is in the highest position of the bobbin case.

Step 4: Place the bobbin case in the machine. Always listen for the pop as it engages in the machine. *See figure 36*

We suggest using a soft bristle brush to wipe out the bobbin case and the bobbin area. Canned air only blows the lint around. By using the soft bristle brush you collect the dust on the brush.

Use a business or index card to clean under the tension spring on the bobbin case *see figure 37*

Each day before you start quilting, unthread your machine past the take up lever and remove the bobbin case, place a small drop of oil in the bobbin hook area before you begin quilting. This will clean out the fuzz and lint. Place a drop of oil in the bobbin hook area. Turn your machine on to run at the slowest setting.



Figure 34



Figure 35



Figure 36



Figure 37

TIP: Lint has a tendency to build up in the bobbin case especially with cotton threads. A tiny amount of lint can cause a huge headache! Check the bobbin case each time you change a bobbin to keep it clean.

Threading overview with names

This is a diagram of the front side of your Long Arm Quilter.

This is the side that faces the fabric. The back of your machine has the electrical outlet and stitch regulator connectors.

The numbers have been assigned in threading order.

See figure 38

1. Upper Thread Guide
2. Three Hole Thread Guide
3. Tension assembly disc
4. Check Spring
5. Silver Angle Bracket
6. Thread Guide
7. Take Up Lever

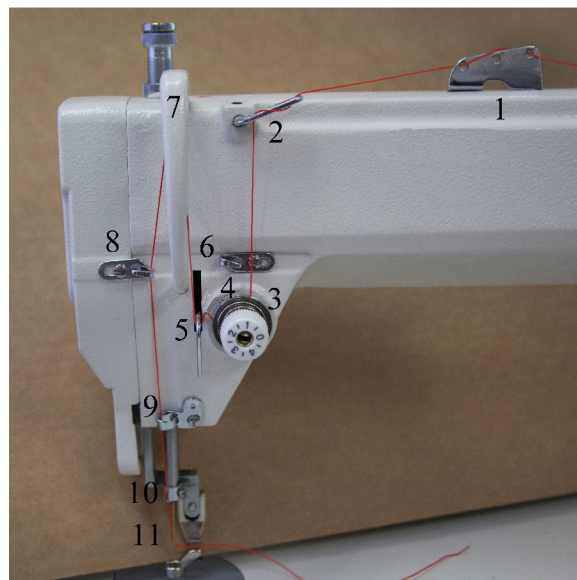

Figure 38

8. Thread Guide
9. Thread Guide
10. Thread Eyelet above the needle
11. Needle

Threading Your Long Arm Quilter

Your Long Arm Quilter is capable of sewing with many types of threads. One thing to keep in mind is this machine is an industrial machine so very light threads will be harder to use than the more traditional machine quilting threads. Use of the other threads is alright as long as you adjust the tension and slow down. These machines are test sewn with Superior King Tut thread which has a long staple and is a machine quilting thread. When we are at quilt shows we use the King Tut on top with a Sofine on the bottom. The reason for this is two threads of equal size will ride on top of each other and fight to interlock. When using a smaller thread in the bobbin you can get more thread on the bobbin and the threads will interlock faster and with less fighting as the smaller thread will nestle right down into the twist of the larger thread creating a better locking of the stitches.

Lets get started threading the machine:

Step 1: Place a cone of thread on the thread holder.

Step 2: Pull the thread through eyelet above the cone of thread. Make sure to use the eyelet directly above the cone of thread. *See figure 39*

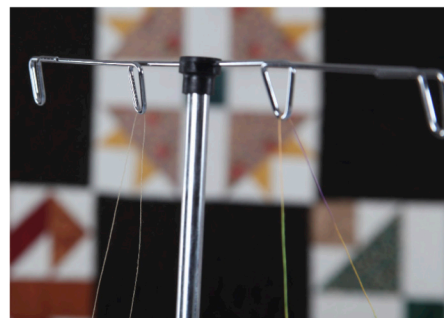

Figure 39

Step 3: Thread upper thread guide as show in figure 40 (if you use all three holes it will add drag/tension to the thread)



Figure 40

Step 4: Weave thread as shown on the three hole thread guide. (if you use all three holes it will add drag/tension to the thread)

See figure 41



Figure 41

Step 5: Take thread between the two tension discs from back to front all the way around. **See figure 42** (release the tension on the tension disc using the tension release lever. This will help to ensure your thread gets between the disc easier.)

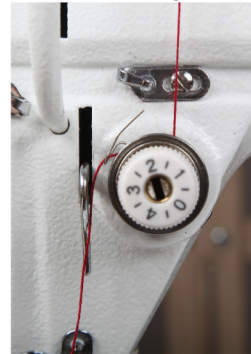

Figure 42

Step 6: While holding the thread up over the top of the tension hook the check spring. The tension spring should come down as you pull thread.



Figure 43

Step 7: Thread now need to run under the silver angle bracket **See figure 43** for details.

Step 8: Now bring the thread up to thread guide #6 above the tension assembly. You will be able to slide the thread into this thread guide. **See figure 44**

Step 9: The thread will now be threaded through the take up lever from the back towards the front. **See figure 45**

Step 10: Now bring the thread down the front of the machine snapping the thread into thread guide 8 and thread guide 9 on the way down to the needle. **See figure 46 and figure 47**

Step 11: The thread will now go into the Thread eyelet above the needle. **See figure 48** This is a hole and you will need to thread this spot.

(TIP: Use a dental floss threader to thread the guide above the needle. The threader will also help thread the needle.)

Step 12: Thread the needle from the front to the back of the needle. **See figure 49**

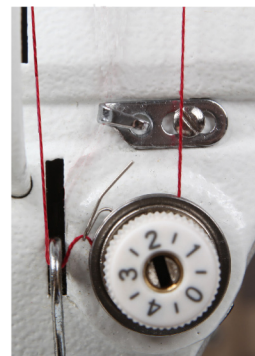

Figure 44



Figure 45



Figure 46

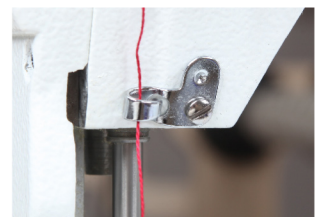

Figure 47

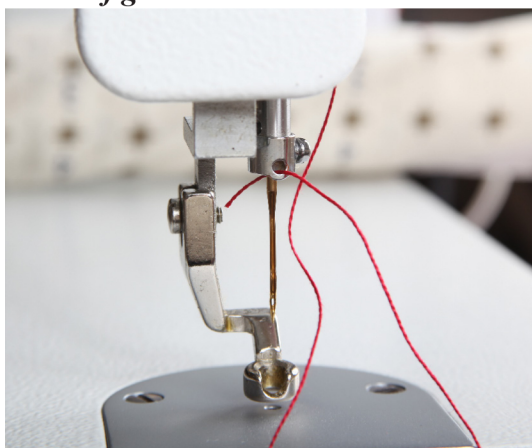

Figure 48



Figure 49 20

How do I change the Needle?

A 134RSAN needle (size 18) will be installed on your Long Arm Quilter from the factory. When it is time to replace the needle you can easily install one. Be sure the power switch is off on the machine. Remove the bobbin case.

To remove the needle use the smaller screwdriver included with your machine.

Step 1: Loosen the screw just above the thread guide on the needle bar; the needle should fall out as you loosen the screw.

Look closely at the needle. Your home sewing machine needle shank (top of the needle) has a flat side. The top of the long arm machine needle is round. On the point end of the needle there is a scarf, or notch, in one side.

The scarf must face the back of your machine.

The long groove at the eye of the needle faces you as you insert the needle.

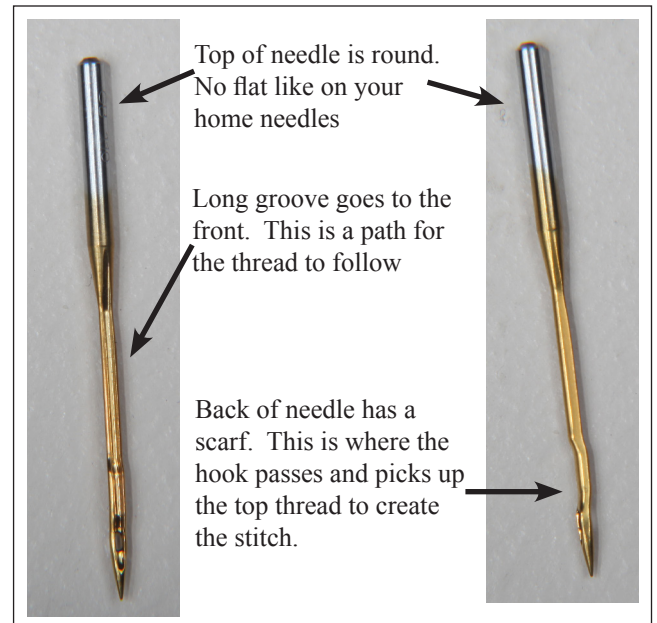

Figure 50

Why does the scarf go to the back of the machine?

When the needle goes down through the fabric into the bobbin case, the hook comes around behind the needle to pick up the thread. The scarf has to be there to provide a way for the hook to get between the needle and the thread in order to pick up the thread.

Step 2: Place the new needle up in the slot, making sure the needle is up in the needle bar as far up as it will go. Make sure the scarf is facing the back of your machine. Tighten the screw on the needle bar while holding the needle up.

TIP: Use the old needle to hold the new needle in place while you tighten the screw. By placing the point of the old needle into the eye of the new needle you can see how straight you are placing the scarf of the needle.

Before you turn your machine on go to the back of the machine and turn the hand wheel a complete turn making sure the needle goes down in the center of the throat plate and the hook in the bobbin area rotates with the needle smoothly. Put the needle down as far as possible. In the bobbin area, you should be able to see you the eye of the needle. When the hook rotates it picks up the thread at the back of the needle then the top thread pulls the bobbin thread up to create a stitch. The scarf must face the back of your machine.

How do I make adjustments to make the perfect stitch?

Understanding how your long arm machine makes a stitch will help you make the proper adjustments to make the perfect stitch. The technique all long arm machines use to make a stitch is basically opposite of the home sewing machine. The home sewing machine is designed to press together two layers of fabric and sew while the fabric is held in place by the presser foot. Long arm machines are designed to press and sew multiple layers together while the machine head is moving. The difference is that there is practically no needle deflection on a standard sewing machine and a large amount of needle deflection on the long arm. The higher the tension, the more the needle will deflect. Another cause for the needle to deflect on a standard machine is the type of fabric being sewn. A tightly woven fabric tends to force the needle in different directions as it penetrates the fabric. This type of deflection depends greatly on the type of needle and type of point you use, such as a ball point or sharp point.

Needle deflection, what is needle deflection? What causes needle deflection? How is needle deflection related to the stitches on my quilt?

On a long arm quilting machine a stitch is mechanically created the same as a home sewing machine except the quilter is the feeddog moving the machine head over the fabric. The hopping foot presses the fabric together tighter and quicker than a home sewing machine presser foot because the fabric must be able to slide between the foot and the needle plate as the machine is sewing. This means that the machine is moving while the needle is in the fabric. The worst thing for a needle is to be in the fabric while the machine is moving which bends the needle, creating needle deflection.

Good stitches will interlock in the batting between the quilt top and backing. In real life, this goal is rarely achieved. For this reason, you need to be aware that you will have “pokies” if you use different colors of thread on top and in the bobbin. Pokies are where you can see tiny dots of the contrasting thread where the bobbin catches the top thread. If there is slightly more tension on the top than on the bottom, then you will see the pokies on the top side of the quilt. If the greater tension is on the bobbin, then you will see the pokies on the back of the quilt. If the pokies are objectionable to you, use the same color thread on both top and bottom.

TIP: *A general rule of thumb is that if the stitch looks bad on the top it is the bottom tension. If the stitch looks bad on the bottom it is the upper tension. The upper and lower threads play tug of war with each other.*

Tension, Tension, Tension

This probably causes more problems than anything else. You need correct tension on the top and bottom threads but you also must have correct tension on the quilt held between the bars. You should be able to gently rock the belly bar where the backing fabric is attached. This allows enough movement of your quilt layers for the needle to penetrate and make good stitches.

Before you start making adjustments to your machine ask yourself, “What changed?” If your machine was stitching great and all of a sudden it has loopies on the back or puckers, “What changed?” Did you just change the bobbin? Did you just lift the take up bar? Did you lower the take up bar after finishing your last quilt? Did you recently change the needle? Did you just roll the quilt?

If the take up bar with the quilted portion of your quilt is too high, it will result in poor stitch quality. You need a finger tip space between the quilt and the machine bed. Higher will result in poor stitch quality. Lower and the quilt will create a drag on your machine’s movement.

Look at your bobbin, a sloppy wound bobbin will not create a good stitch. Make sure that the threads on the bobbin are snug and evenly wound. Check to see if there is a piece of lint in the bobbin case.

Tension Trouble shooting checklist

- Is the side tension lever down?
- Have I oiled my machine regularly?
- Is the quilt too tight on the frame?
- Is the thread coming off the cone freely?
- Has your thread jumped out of the tension discs?
- Check your threading. Has anything been missed or has the thread flipped itself around something, increasing your tension?
- Is the hopping foot too high or too low?
- Is your take up bar too high? Did you lower the take up bar after your last quilt?
- Do you need to change your needle?
- Is your needle in properly?

Top Thread Breaking

- Check to see that your thread is coming off the spool freely. The thread guide is centered over the spool and has not developed any burrs or catches.
- Check to see if the thread has looped itself around the spool pin.
- Check to see if the needle is in correctly, with the scarf facing the back of the machine.
- Have you recently changed the needle? Is it as high as it will go in the needle bar?

The Stitch Regulator does not keep up with me? Just like driving your car you need to make controlled starts and stops, practice being consistent in your movements.

Eyelashes

Eyelashes on the back of the quilt can be caused by too little top tension. Turn the thread tension disk clockwise ¼ turn. Make small adjustments. Repeat until stitch quality is good. Remember the upper and lower thread play tug of war with each other.

Loose Top Stitch

Is the tension lever handle down? It lowers the hopping foot and applies the tension disk.

Is the bobbin thread inserted in the slot of the bobbin case?

Adjust the tension disk small turns clock wise. Repeat until stitch quality if good.

Quilt Top Puckers

Is your backing fabric stretched too tight? While the backing fabric needs to lie flat and without wrinkles, stretching it too tight can make the quilt top pucker. After stitching and releasing the backing fabric the top will pucker.

The top tension is too tight. Adjust the tension disc small turns counter clockwise. Repeat until stitch quality is good.

Stitches are Skipped

Skipped stitches leave needle holes without thread while large and small stitches in regulated mode means the encoders are not picking-up the signal of your movements because of lint or thread stopping or slowing the reading.

First, check to see that your machine is threaded correctly. Look at the check spring, does the thread lay in the check spring? When properly threaded the check spring will move up and down as the machine is stitching and the thread is flowing freely.

Check the needle. Be sure it is all the way up into the shaft and the scarf is toward the back. If it has been used for some time, replace the needle. A blunt needle will make a popping sound as it penetrates the quilt sandwich.

Machine Drags Making it Difficult to Move

Check to make sure the quilt on the take up bar is not dragging on the bed of the machine. A finger tip distance between the take up bar and the bed of the machine is all that is necessary. Elevating the take up bar too high can cause loopies on the back. Look for lint or thread that might be snagging as you move the machine.

Difficult to Control the Movement of the Machine

Check for lint or other debris on the track and bars. Sometimes the smallest pieces of thread create the biggest headaches.

Check spring replacement/Tension Knob

From time to time you may need to replace the check spring. We will use a series of photos to help you.

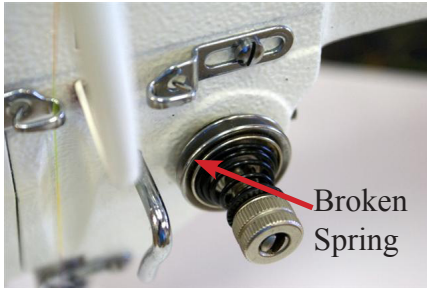

Figure 51

Tension Assembly with Broken Spring.
(old tension knob)



Figure 52

Tension Assembly with good
spring (new Tension knob)

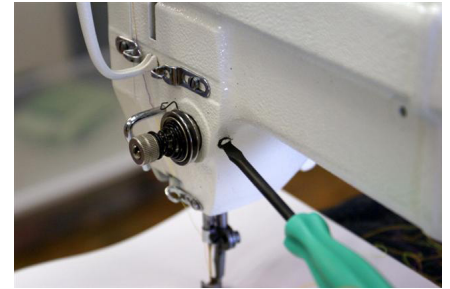

Figure 53

Screw on inside of machine loosen
only. **DO NOT REMOVE**



Figure 54

Remove assembly from machine
Be careful of release pin



Figure 55

Machine with tension assembly re-
moved

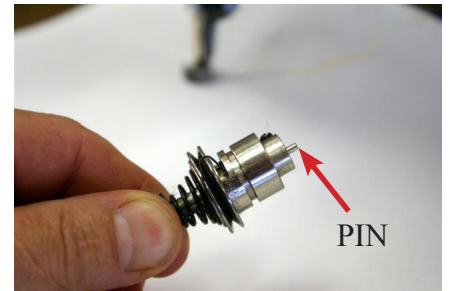

Figure 56

Tension assembly out of machine
DO NOT LOOSE PIN

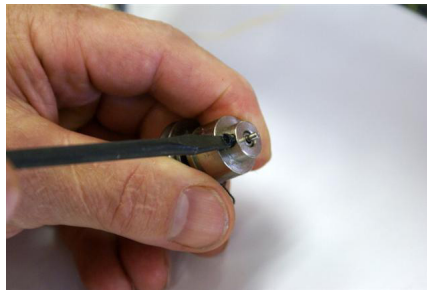

Figure 57

Loosen screw only
DO NOT REMOVE



Figure 58

Remove tension assembly from barrel

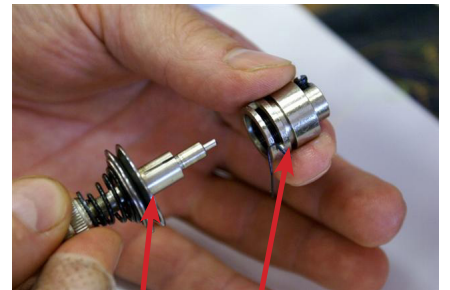

Figure 59

Tension assembly, Barrel



Figure 60

Remove spring



Figure 61

Spring Removal

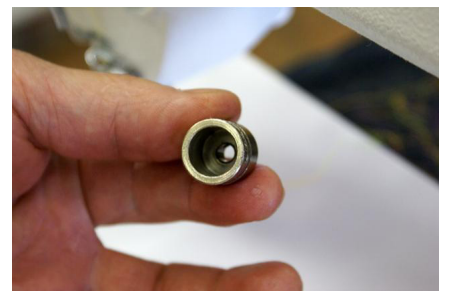

Figure 62

Spring Removed

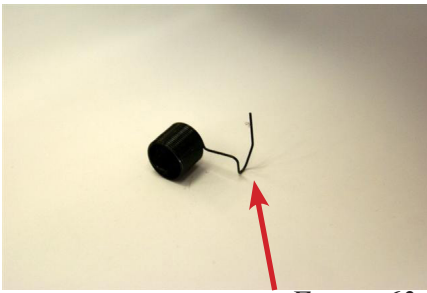

Figure 63

New Spring, This tail is what was broken



Figure 64

Insert the new spring

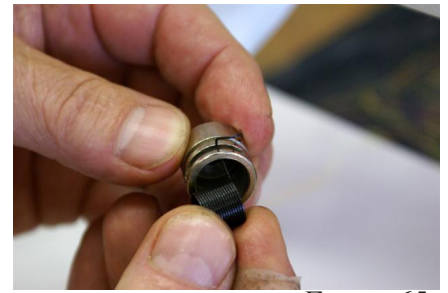

Figure 65

Twist while inserting the new spring

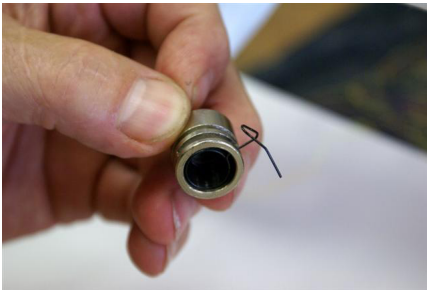

Figure 67

New spring in place



Figure 68

Insert the tension assembly back into the barrel. REMEMBER DO NOT LOOSE THE PIN



Figure 69

Insure that you are all the way in



Figure 70

Give the tension assembly a twist until you feel resistance on the check spring

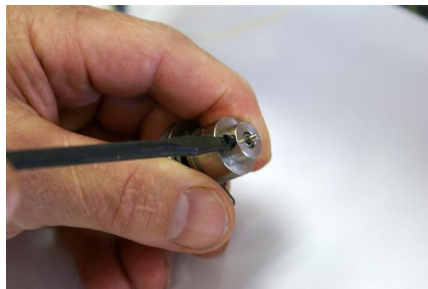

Figure 71

Tighten screw. Make sure the pin is still there.



Figure 72

Place the assembly back into your machine



Figure 73

Once in ensure that your check spring is at 11:00



Figure 74

Press in and notice the tension disk opens



Figure 75

Release and the disk will close; this is the proper place for your tension assembly



Figure 76

Tighten screw on your machine



Figure 77

Tension assembly back in place with new check spring at 11:00

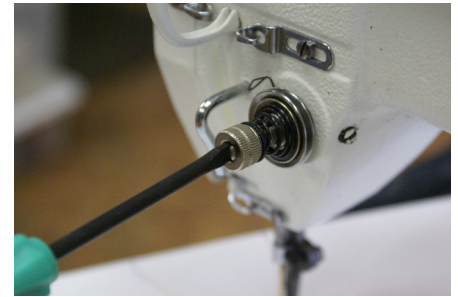

Figure 78

For fine adjustment of check spring insert screwdriver turn clockwise for more tension

Machine will not sew. I can not turn the hand wheel

No matter how hard you try to keep the bobbin area free of loose threads and lint we sometimes with get a jam. Most jams start with the needle down as the jam is because something gets into the bobbin race. The bobbin race is a part of the bobbin hook which keep the hook rotating smoothly and no wandering as it rotates.

Don't panic this can be cleared it just sometimes take some work.

Step 1: Turn the power off

Step 2: Remove the belt guard so that you can get a good grip on the hand wheel. See page 10 for instructions

Normal sew rotation if you are standing at the back of the machine looking at the hand wheel is counter clockwise. If you turn the machine counter clockwise you will force what ever is jamming the machine deeper into the bobbin race.

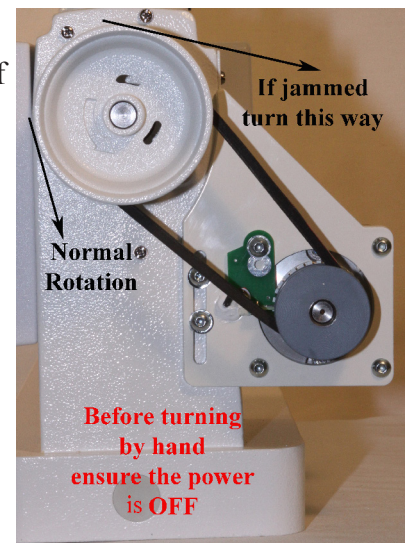

Figure 79

Step 3: Rotate the hand wheel clockwise to back the jam out of the bobbin race. (This may take some work to get it worked free.) *See figure 79*

Step 4: Normally when you get it backed up it will fall out and you will be able to make a full rotation with the hand wheel.

Once it feels free take the needle plate off the machine and give it a good cleaning in the bobbin area. Prior to putting the needle plate back on rotate the hand wheel counter clockwise (normal machine rotation)

While rotating the hand wheel by hand ensure that you have free movement of the machine. If everything is working well you can put the needle plate back on and put the belt guard back on, You will be ready to start quilting again.



Figure 80

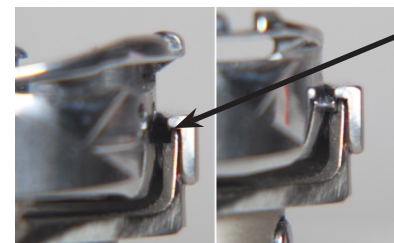

The Race is this small space here on the hook assembly

Figure 81

Figure 80 shows thread caught
Figure 81 show the race

Timing between needle and rotating hook

If you need to adjust the timing of the machine follow these steps to help get the proper timing on your machines.

Step 1: Remove the two needle plate screws from your machine and set the needle plate to the side

Step 2: Remove the two screws on the protection cover at attach it to the face plate of the machine. *See figure 82*



Figure 82

Step 3: Remove the three screws holding the face plate to the machine. Remove the face plate and set this part aside.

Step 4: Check the protection flange of the position bracket (A). This should be engaged in the notch (B) of the bobbin case holder. (D) in the drawing shows the set screw to adjust hook timing. *See figure 83*

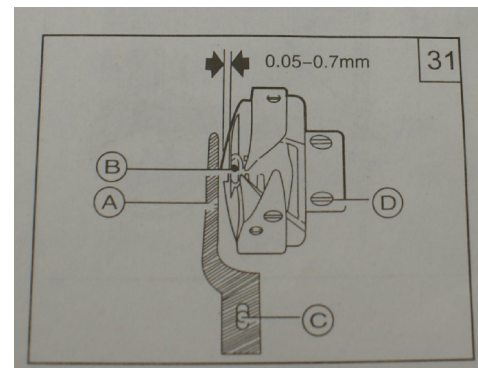

Figure 83

Step 5: Turn the hand wheel to locate the needle to its lowest position. Note: correct needle position is when you can see a small portion of the eye of the needle. *See figure 84*

Step 6: If the needle is not stopping in the correct position you will need to proceed to the next step. If it is in the correct position move to step 9

Step 7: Loosen Needle bar connecting screw (A) This will allow you to raise and lower the needle bar for correct location. NOTE: CHECK ALL PHOTOS BEFORE MAKING ANY ADJUSTMENTS *See figure 85*

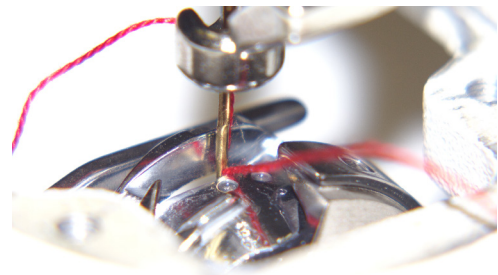

Figure 84

Step 8: Once you have the needle in the correct location tighten Needle bar connecting screw (A) to prevent the needle bar from moving out of position.

Adjusting rotating hook point timing with needle

Step 9: Turn the hand wheel counter clockwise to locate needle to its lowest position.

Step 10: At lowest position turn the hand wheel to raise the needle 2.5 mm (1/8") *See figure 85*

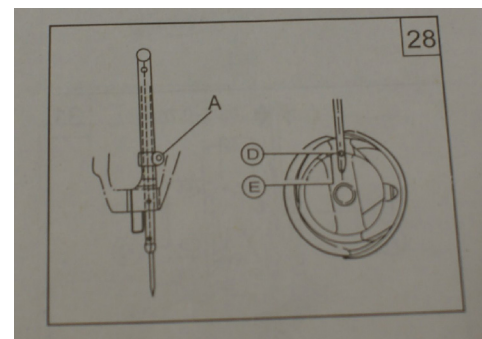

Figure 85

Step 11: Hook point should be just above eye of the needle. *See figure 87*

Step 12: If the hook point is in the correct position then move to step 18. If the hook point is past this point or not yet reached this position then you will need to follow the next few steps to adjust the hook so that when the hook point reaches this position it is just above the eye of the needle. Proceed to the next step.

Step 13: Refer to drawing 31 *see figure 83* for position of the three screws (D). Loosen the three screws holding the hook assembly to the shaft. (Note you will have to rotate the hand wheel to get to all three screws.)

Step 14: With the hook loose reposition the needle to the lowest position. Rotate the hand wheel counter clockwise to bring the needle up 2.5mm (1/8") *see figure 86*

Step 15: Now rotate the hook so that the point of the hook is just at the edge of the needle. *See figure 87*

Step 16: Lock one screw holding the hook into this position.

Step 17: Rock the hand wheel back and forth to ensure that you have the hook in the right position to pass the back of the needle just above the eye of the needle.

Step 18: When adjusting the rotating hook point timing also note that clearance between notch bottom of needle D and hook point C must be maintained. HOOK CAN NOT RUB AGAINST NEEDLE.

Step 19: Once you feel like everything is in the right place tighten all screws you loosened.

Step 20: Return all covers and screws back into place on your machine.

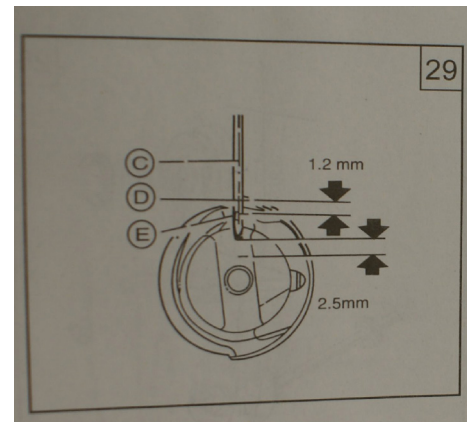

Figure 86

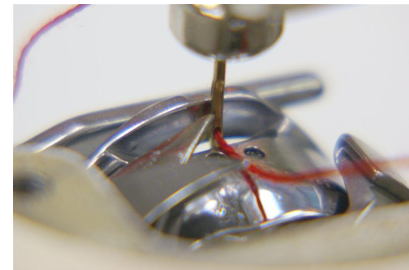

Figure 87

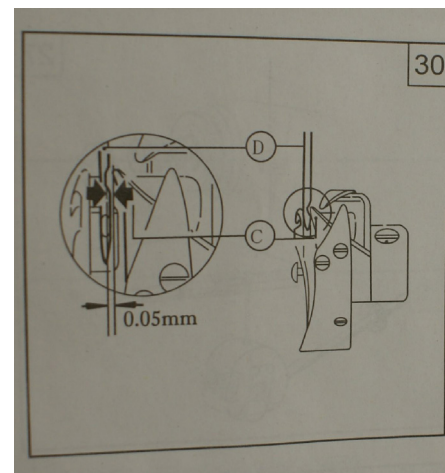

Figure 88

Adjusting the bobbin winder lever (amount of fill on the bobbin)

Step 1: Using your allen wrench loosen the set screw (A) holding the Bobbin winder Lever (B) in place. *See figure 89 and 90*
Note you do not need to pull the bobbin winder out to adjust this setting.

Step 2: Move the Bobbin winder lever in for less fill and out for more fill

Step 3: Tighten set screw (A) to prevent Bobbin winder lever (B) from moving

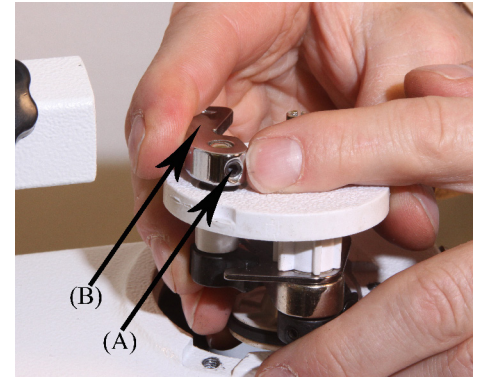

Figure 89

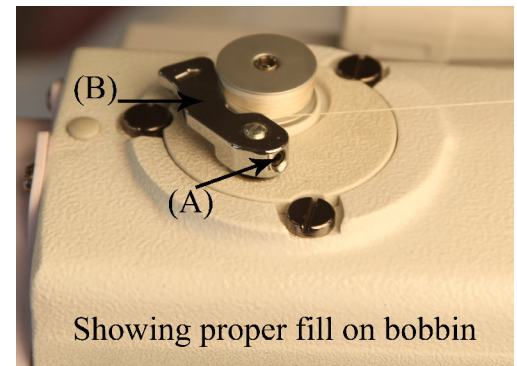

Figure 90

Adjusting the tension assembly thread guides for proper fill.

Step 1: Loosen the set screw (D) so that you can adjust the tension assembly thread guides (E). Adjust tension assembly thread guides (E) up and down until bobbin fills evenly top to bottom.
See figure 91

Step 2: Tighten the set screw.

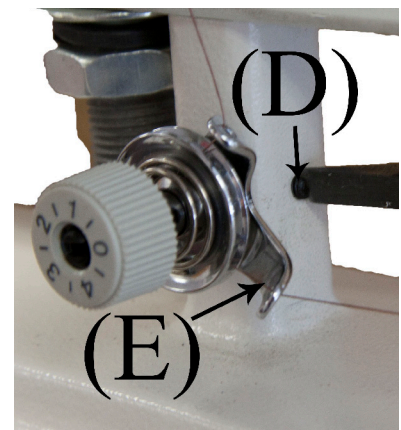

Figure 91

Adjusting bobbin winder and contact with the shaft

Step 1: Loosen the three (3) screws (A) holding the bobbin winder in place but do not remove them. *See figure 92*

Step 2: Twist the bobbin winder (B) to the right for more contact with the inner shaft or mover left for less contact.

Note: When twisting the bobbin winder (B) you need to stand on the side of the machine with the access panel

Step 3: The bobbin winder disk with the friction ring needs to contact the disk on the upper shaft when engaged. *See figure 93*

Step 4: Once done moving the bobbin winder retighten the screws to hold the bobbin winder in place.

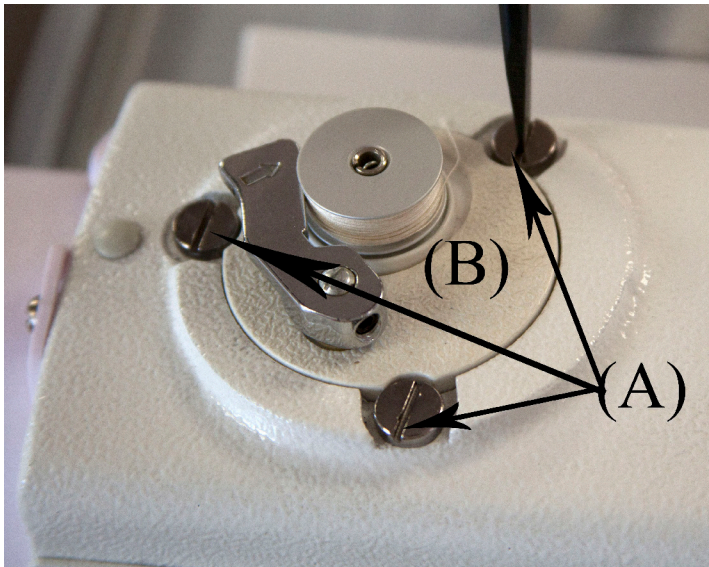

Figure 92

Turning the bobbin winder to the right will move the friction wheel closer

Turning the bobbin winder to the left will move the friction wheel away

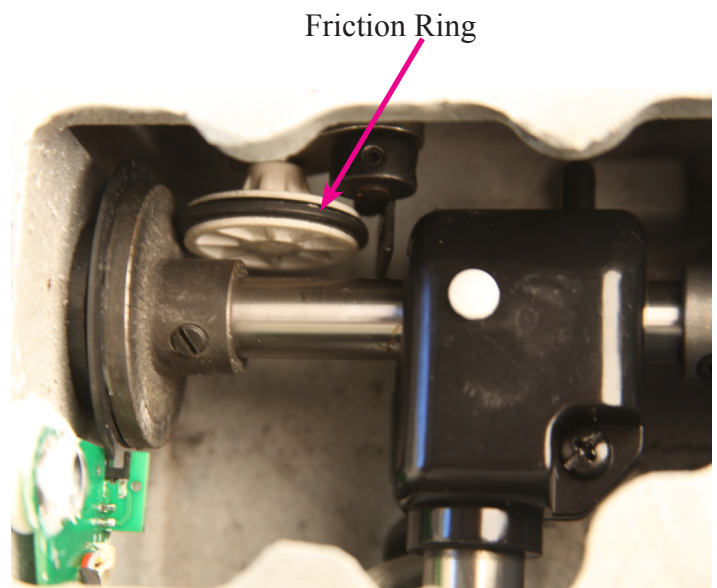

Figure 93

Attaching the Rear Handle Bars

The following instructions will help you install the rear handle bars to your Long Arm Quilter

Step 1: Locate your rear handles. **See figure 94**

Step 2: These handles are going to connect to the handle bar block on the back of the machine below the belt guard on the base of the machine.

See figure 95

Step 3: Remove the two screws holding the outer block on the machine.

Step 4: Position the handle bar in the space provided and reattach the outer block and the two screws.

Step 5: Before securing the handle bar, position the handle bar so that you are able to use them and they will not hit anything as you move the machine along the frame.

Step 6: Connecting the cables. You should have two short RJ50 cables with the rear handle set.

Step 7: Connect one short RJ50 cable to the middle port on the left handle bar controller. The other end of the cable will connect to the thumb controller on the right handle bar. On the thumb controller on the right handle bar are two ports. The RJ50 from the left handle bar needs to plug into the left connector on this thumb controller.

Step 8: Connect the other short RJ50 cable to the port on the left side of the left controller. Now the other side of this RJ50 cable will connect to the top port on the back of the white box where the power cord plugs in.

Step 9: The RJ50 cable which is hanging out of the bottom of the white box where the power cord plugs in will be plugged into the right port on the left handle bar controller.

When you have all the cables connected to the LCD controller on the rear handles left side all the ports will have a cable connected. The left port cable will connect to the large RJ50 port on the white box. The center port will connect to the left port on the right handle bar thumb control. The right port will connect to the cable which was hanging out of the bottom of the white box.



figure 94

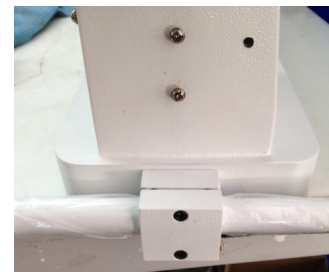
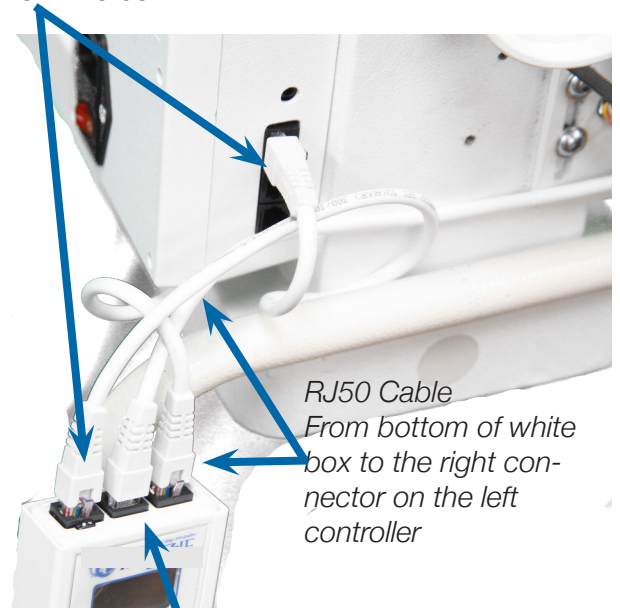

figure 95

*Short RJ50 Cable
From left port on the left hand
controller to the upper connector
on the white box.*



*RJ50 Cable
From bottom of white
box to the right con-
nector on the left
controller*

*Short RJ50 Cable
From center port to
Thumb controller on
the right*