

Quilter's Pro

SITDOWN MODEL

User Guide



Table of Contents

Warranty.....	3
Attaching your Square Tubing	4
Your Light Fixture	5
Your Thread Stand	6
What is the Tension Release Lever?.....	7
How Do I Adjust the Height of the Hopping Foot?	7
Routine Cleaning and Oiling.....	8
Bobbin Winder and Bobbins	9
Machine Part Names	12
Threading Overview	13
How Do I Thread the Machine?	13
How Do I Change the Needle?	16
How Do I Make Adjustments to Make the Perfect Stitch?	17
Tension, Tension, Tension	18
Trouble Shooting Checklist	

Warranty

We believe that we have designed and are manufacturing the best long arm quilting machine available. **As you unpack your machine, be sure to keep the box and packing materials designed to protect the machine during shipping. Should it become necessary for you to return the machine for warranty work, please call us for specific instructions for packing and shipping your machine.**

- Your Quilter's Pro Sitdown has a full labor warranty for one year from the day you receive your machine. We guarantee the machine parts for five years.
- The machine must be cleaned and oiled regularly according to the instructions in this manual. Failure to properly maintain the machine will void this warranty.
- Your Quilter's Pro Sitdown must be plugged into a surge-protected electrical outlet. We highly recommend using an Uninterrupted Power Supply (UPS) also known as a Battery Backup. This helps to ensure that you are getting a regulated 110 volts into your machine. (See photo below of UPS battery backup.)
- Should we mutually decide that your machine cannot be repaired using normal communications, we will arrange for the machine to be returned to the factory.

Should You Have a Problem

Please contact the dealer where you purchased your machine. They are also your servicing dealership.

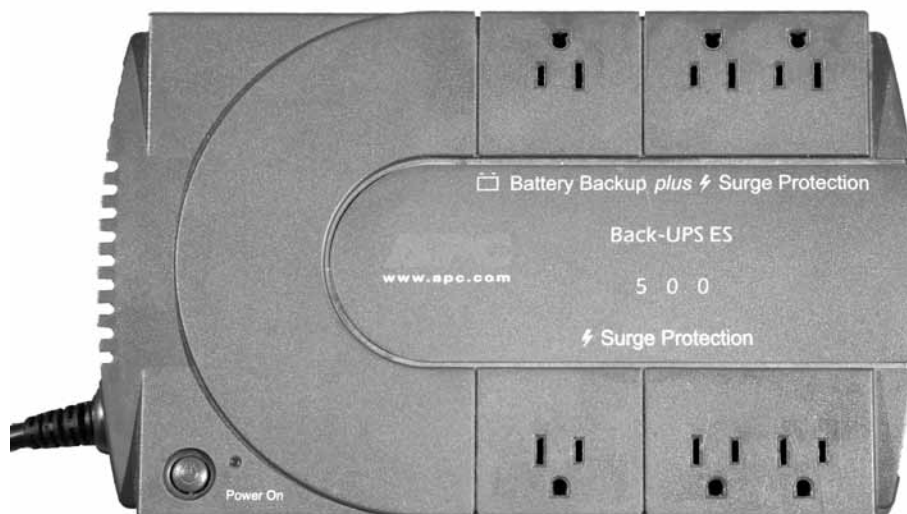

Your Light Fixture

To add your light fixture to your machine, first loosen the nut and washer from the base of the light fixture.

Slide the lamp base into the lamp holder on the side of the machine.

Your light fixture came with a long cord. At this time you can trim the cord so that it will reach the outlet on top of the power box. This outlet is also where you will find the plug for your lamp.

Open your plug by pulling on the silver tab and open the plug. Trim the wires flush, with enough to reach the outlet on the top of the power box. Lay the wires in the space provided in the plug and close the plug. **Caution:** Before you close, make sure that you do not have any wires crossed, as this will create a short.

Plug in and enjoy light as you quilt.

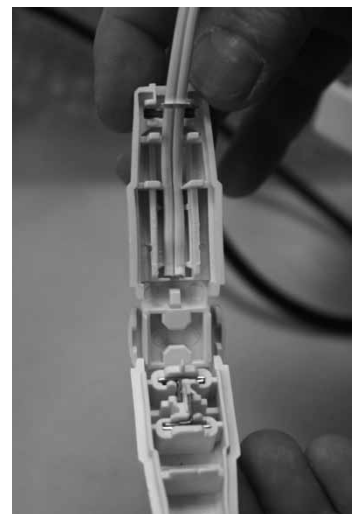
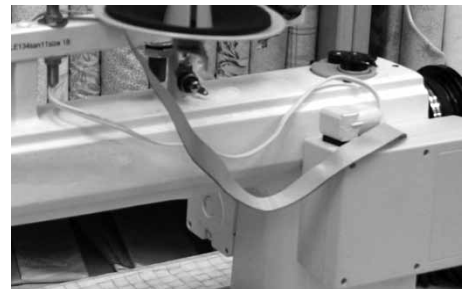
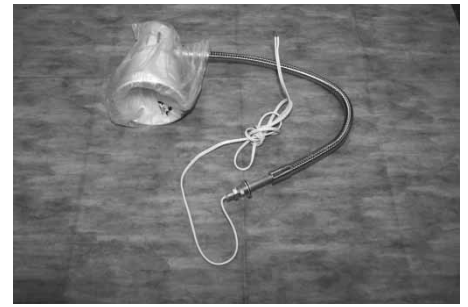

Your Thread Stand

Your Quilter's Pro Sitdown model comes with a four-spool Thread Stand. Some assembly required.

Attach the upper thread support to the cone support base.

1. Place the upper thread support into the hole provided on the base between the cone holders.
2. Use the screw provided to secure the upper thread support into place.

To attach the Thread Stand on the side of the machine with the motor, you will see two screws toward the front of the machine.

1. Loosen the two screws on the side of the machine.
2. Slide the Thread Stand over the two screws.
3. Level the Thread Stand with the top of the machine.
4. Tighten the two screws to hold the Thread Stand securely in place.

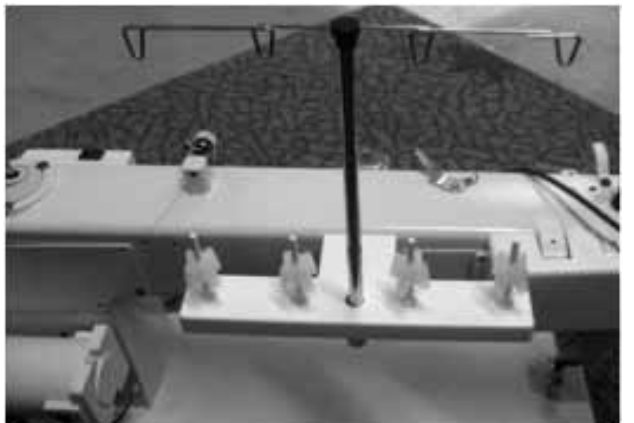
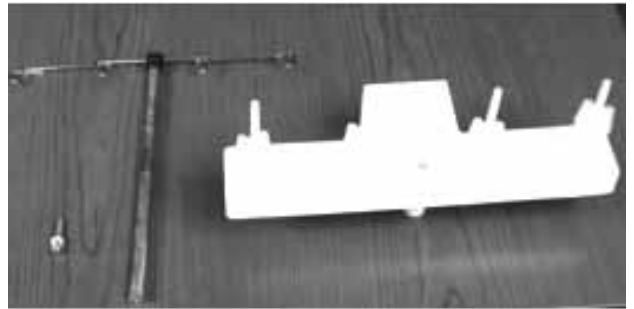

Connecting the Foot Control

The Foot Control is connected to the power supply box on the bottom side of the box. Plug the Foot Control plug into the jack provided on the base of the power supply.

Turn the sewing speed controller dial to the right to increase the motor speed; turn the dial to the left to decrease the motor speed.

Needle position buttons:

Power cord connection:

Foot control connection is under here:

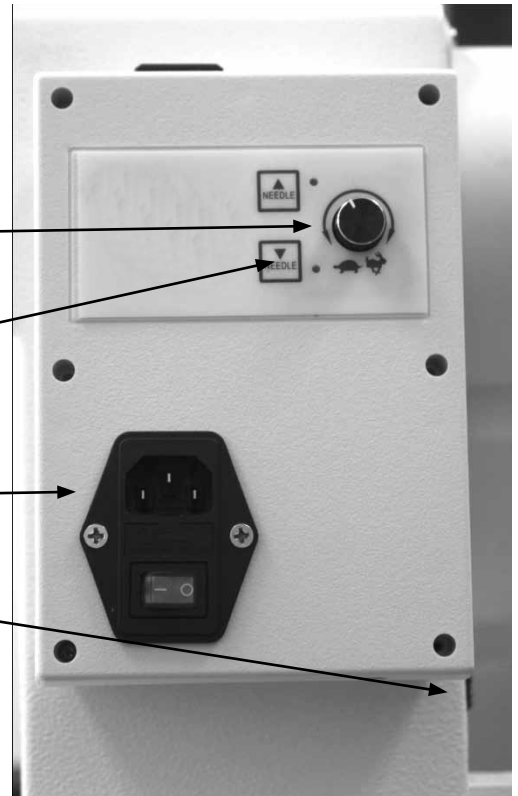

Needle Position

For needle up, tap the foot pedal. This will cause the machine to make one full rotation, bringing the needle to the up position. Pressing the foot pedal slowly will position the needle down. This may take some test presses to get it down, and to get the feel for the foot pedal needle control. Alternatively, you can use the buttons on the control panel.

Needle Up Position:

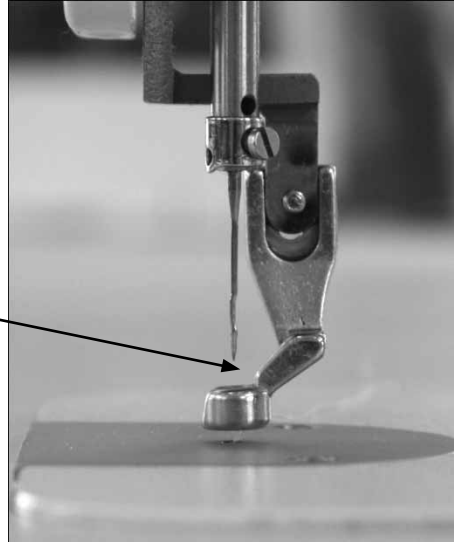

Needle Down Position:

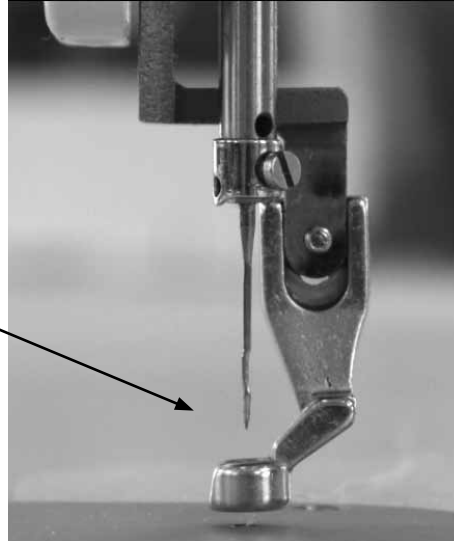

What is the Tension Release Lever?

The Tension Release Lever raises the Hopping Foot and releases the tension on the thread. You can watch the tension disc plates open as you lift the lever.

NEVER start sewing with the lever up, because there is no tension on the thread, and the bottom stitches will be huge loops.

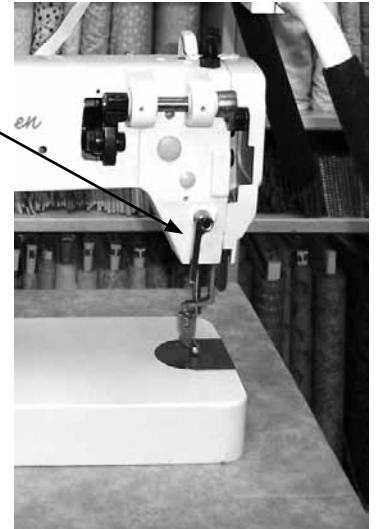

How Do I Adjust the Height of the Hopping Foot for Thicker or Thinner Batting?

Adjustment Screw:

If you are quilting on batting that is thicker than normal, you might need to raise the Hopping Foot. Loosen the screw holding the Hopping Foot on, slide the foot up for thicker or down for thinner. Be sure to tighten the screw after your adjustment.

The normal height of the Hopping Foot should be approximately the height of a dime, or three business cards when the needle is in the down position.

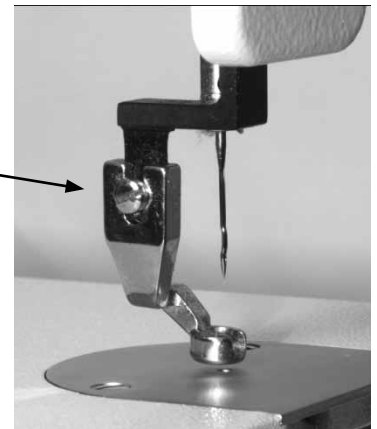

Routine Cleaning and Oiling

Routine cleaning and oiling is very important to the longevity of your quilting machine. Brush out the fuzz from around the hook and foot. Change your needle regularly to avoid thread breakage, tension problems and needle breakage. A worn needle can mean skipped stitches, shredded thread and a weakening of the needle itself. These things can lead to stitch quality issues.

Lint has a tendency to build up in the bobbin case. A tiny amount of lint can cause poor stitches. Check the bobbin case each time you change the bobbin to keep it clean. We suggest using a soft bristle brush to wipe out the bobbin case and the bobbin area. Canned air only blows the lint around. By using a soft bristle brush you collect the dust on the brush. Occasionally, place a drop of machine oil on a cotton swab to wipe out the bobbin case.

Keep your table clean of dust and oil. Clean the bars and carriage deck regularly for smooth movement.

Oiling is extremely important to the longevity of your quilting machine. Failure to oil your machine regularly can void your warranty.

The one oiling spot marked with red arrow is marked with red paint on your machine. An oil bottle is included with your machine. The one oiling spot marked with a blue arrow contains a dip stick. Remove the dip stick by lifting it up with a finger nail or screw driver. Place drops of oil in this hole.

Recommended oiling: After every finished quilt, place 3 to 4 drops of oil in the indicated spot. At this time, make sure oil is present on the dip stick. If not, add 3-4 more drops of oil. Run the machine to lubricate. When you run out of oil, please purchase high grade sewing machine oil. ***(Note: The machine pictured here is before complete assembly from factory; your machine has more components attached.)***

Oil point top of machine



Oil Reservoir with dip stick

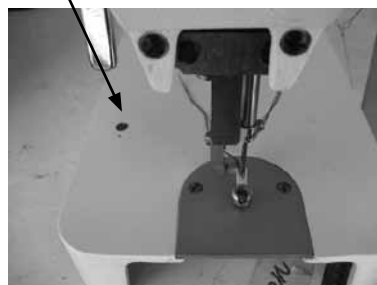

Oil Reservoir with dip stick removed



Bobbin Winder and Bobbins

A Bobbin Winder is included with your machine. The thread on a properly wound bobbin should be snug and have even layers of thread. A sloppy or mushy wound bobbin will result in poor stitch quality.

Bobbin Thread:

Bobbin Thread Guide:

Bobbin Winder:

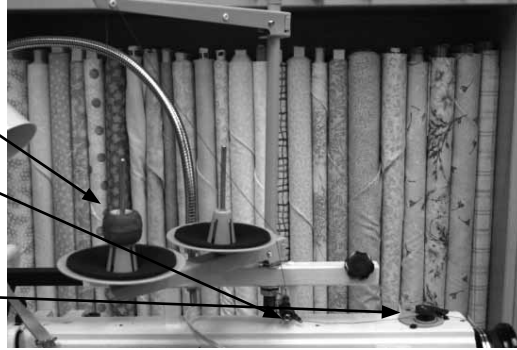

How do I wind a Bobbin?

1. Insert an empty bobbin on the Bobbin Winder spindle.
2. Place a cone of thread on the holder.
3. Bring the thread up through the guide over the cone of thread.
4. Insert the thread through the top guide hole, then around the tension disc and through the bottom thread guide. This tension is for the bobbin tension when filling the bobbin.

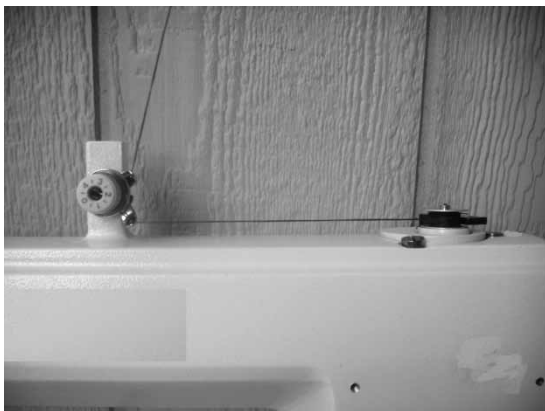
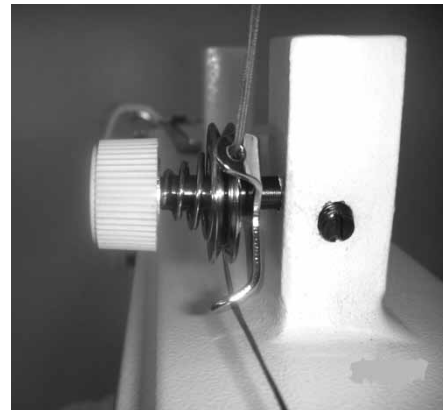
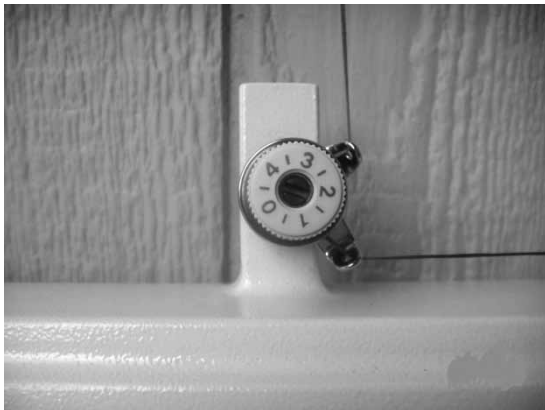

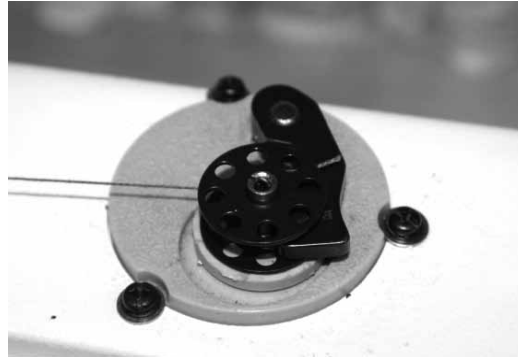

5. Wrap the thread around the bobbin three or four times.
6. Push the trip mechanism forward until it snaps into position.
7. The Bobbin Winder will start winding the bobbin once you press the foot pedal. You can quilt while your bobbin is winding. Once it is full, it will stop.
8. If you wind your bobbin only (when not quilting), ensure that you do not have thread in the needle to prevent jams. Also remove the bobbin and bobbin case to prevent damage.

NOTE: There is no way to stop the needle from moving while the bobbin is winding.

The bobbin will fill until the trip mechanism is pushed out by the thread. It will then disengage the wheel. The bobbin should fill to just below the rim. Having the bobbin too full will cause tension problems.

Bobbing Fill Mechanism

This picture is provided for your reference should you need to make an adjustment to your bobbin fill mechanism. Never adjust unless you are told to do so by our technicians.



Check the tension of the bobbin by holding the loaded bobbin case in one hand. With one hand under the bobbin case, hold the tail of thread and watch as the thread flows out of the bobbin case. A slight bounce should cause the bobbin case to slide down the thread. If the thread slides out of the case as you pick it up, it needs more tension. If it barely moves down the thread or doesn't move at all, it needs less tension.



Use a small screwdriver to turn the largest set screw on the bobbin case to adjust tension. Make very, very small adjustments. Be very careful not to remove the screw as it is very small and difficult to find if lost. Remember, righty (clockwise) tighty, lefty (counter clockwise) loosey.

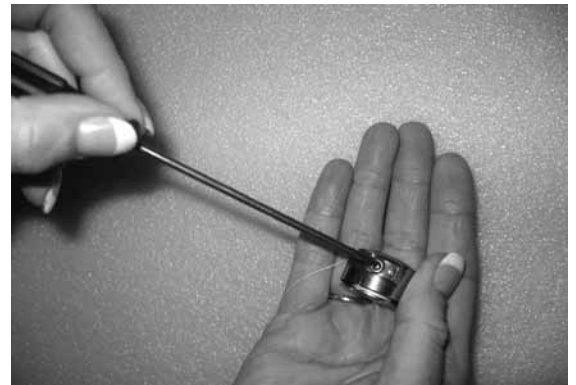

To place the bobbin into the machine

1. Insert the bobbin into the bobbin case.
2. Holding the bobbin case, pull the thread through the slot.
3. Draw the thread down and under the spring, making sure the thread is in the highest position of the bobbin case.
4. Place the bobbin case in the machine.
Always listen for the pop as it engages in the machine.



We suggest using a soft bristle brush to wipe out the bobbin case and the bobbin area. Canned air only blows the lint around. By using the soft bristle brush you collect the dust on the brush.

Each day before you start quilting, unthread your machine past the take up lever and remove the bobbin case. Place a small drop of oil in the bobbin hook area before you begin quilting. This will clean out the fuzz and lint. Place a drop of oil in the bobbin hook area. Turn your machine on to run at the slowest setting.

TIP: Lint has a tendency to build up in the bobbin case, especially with cotton threads. A tiny amount of lint can cause a huge headache! Check the bobbin each time you change it to keep it clean.

Machine Part Names



(Please note: the takeup lever guard has been removed for a clear view for pictures only. Never run the machine without the guard in place. Extreme head injury may occur.)

This is a diagram of the side of your long arm machine. The front of the machine faces the belly bar. The back of your machine has the electrical outlet and stitch regulator plugs. The numbers have been assigned in threading order.

- | | |
|--|------------------------------------|
| 1. Upper Thread Guide | 6. Thread Guide |
| (Note: some machines do not have this) | 7. Take Up Lever |
| 2. Three Hole Thread Guide | 8. Thread Guide |
| 3. Tension Disc | 9. Thread Guide |
| 4. Check Spring | 10. Thread Eyelet Above the Needle |
| 5. Silver Angle Bracket | 11. Needle |

Threading Overview

Please note: The takeup lever guard has been removed for a clear view for pictures only. Never run the machine without the guard in place. Extreme head injury may occur.

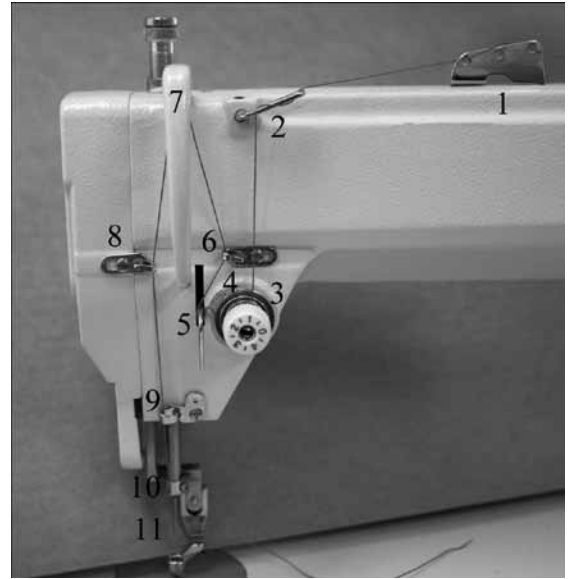

How Do I Thread the Machine?

1. Place a cone of thread on the thread holder.
Figure 1
2. Pull thread through the eyelet above the cone of thread. Make sure the eyelet is directly above the thread cone. **Figure 1**
3. Thread the upper thread guide as shown in picture. **Figure 2**

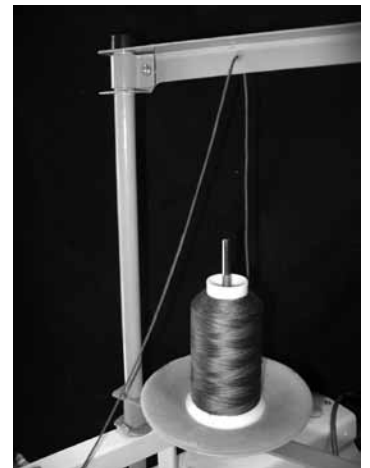

Figure 1

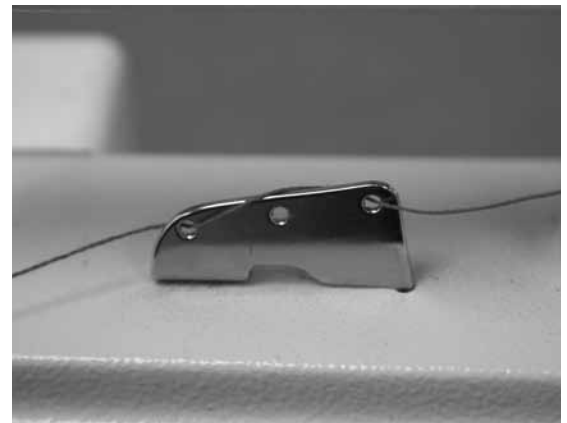

Figure 2

4. Weave thread as shown on three hole thread guide. **Figure 3**

5. Take thread between the two tension discs from back to front all the way around, up and over the check spring. Be sure the thread is going between the discs, and go far enough to catch the check spring. The check spring should come down as you pull the thread. Pull the thread tightly to ensure the thread is in the tension disc. **Figure 4**

6. Thread runs under silver angle bracket. See picture for details. **Figure 4**

7. Bring the thread up through the thread guide just above the check spring. **Figure 4**

8. Take the thread through the take up lever from back to front. **Figure 5**

9. Bring the thread down through the two thread guides on the left side.

10. Bring the thread through the thread eyelet directly above the needle. **Figure 6**

11. Thread the needle left to right. **Figure 6**

TIP: Use a dental floss threader to thread the guide directly above the needle. The threader will also thread your needle.



Figure 3



Figure 4



Figure 5

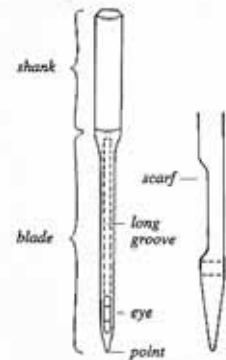

Figure 6

How Do I Change the Needle?

A 134RSAN needle (size 18) will be installed on your Quilter's Pro Sitdown model from the factory. When it is time to replace the needle, you can easily install one. Be sure the power switch is off on the machine. Remove the bobbin case.

To remove the needle, use the smaller screwdriver included with your machine. Loosen the screw just above the thread guide on the needle bar; the needle should fall out as you loosen the screw. Look closely at the needle. Your home sewing machine needle shank (top of the needle) has a flat side. The top of the long arm machine needle is round. On the point end of the needle there is a scarf, or notch, in one side. **The scarf must face the right of your machine. The long groove at the eye of the needle faces left as you insert the needle.**



Why does the scarf go to the right of the machine?

When the needle goes down through the fabric into the bobbin case, the hook comes around behind the needle to pick up the thread. The scarf has to be there to provide a way for the hook to get between the needle and the thread in order to pick up the thread.

Place the new needle up in the slot, making sure the needle is up in the needle bar as far up as it will go. Make sure the scarf is facing the right of your machine. Tighten the screw on the needle bar while holding the needle up.

TIP: Use the old needle to hold the new needle in place while you tighten the screw. By placing the point of the old needle into the eye of the new needle, you can see how straight you are placing the scarf of the needle.

Before you turn your machine on, go to the back of the machine and turn the hand wheel a complete turn making sure the needle goes down in the center of the throat plate, and the hook in the bobbin area rotates with the needle smoothly. Put the needle down as far as possible. In the bobbin area, you should be able to see you the eye of the needle. When the hook rotates, it picks up the thread at the back of the needle, then the top thread pulls the bobbin thread up to create a stitch. The scarf must face the right of your machine.

How Do I Make Adjustments to Make the Perfect Stitch?

Understanding how your long arm machine makes a stitch will help you make the proper adjustments to make the perfect stitch. The technique all long arm machines use to make a stitch is basically opposite of the home sewing machine. The home sewing machine is designed to press together two layers of fabric and sew while the fabric is held in place by the presser foot. Long arm machines are designed to press and sew multiple layers together while the machine head is moving. The difference is that there is practically no needle deflection on a standard sewing machine and a large amount of needle deflection on the long arm. The higher the tension, the more the needle will deflect. Another cause for the needle to deflect on a standard machine is the type of fabric being sewn. A tightly woven fabric tends to force the needle in different directions as it penetrates the fabric. This type of deflection depends greatly on the type of needle and type of point you use, such as a ball point or sharp point.

What is Needle Deflection? What Causes Needle Deflection? How is Needle Deflection Related to the Stitches on my Quilt?

On a long arm quilting machine, a stitch is mechanically created the same as a home sewing machine, except the quilter is the feed dog, moving the machine head over the fabric. The hopping foot presses the fabric together tighter and quicker than a home sewing machine presser foot, because the fabric must be able to slide between the foot and the needle plate as the machine is sewing. This means that the machine is moving while the needle is in the fabric. The worst thing for a needle is to be in the fabric while the machine is moving, which bends the needle, creating needle deflection.

Good stitches will interlock in the batting between the quilt top and backing. In real life, this goal is rarely achieved. For this reason, you need to be aware that you will have “pokies” if you use different colors of thread on top and in the bobbin. Pokies are where you can see tiny dots of the contrasting thread where the bobbin catches the top thread. If there is slightly more tension on the top than on the bottom, then you will see the pokies on the top side of the quilt. If the greater tension is on the bobbin, then you will see the pokies on the back of the quilt. If the pokies are objectionable to you, use the same color thread on both top and bottom.

Tip: A general rule of thumb is that if the stitch looks bad on the top, it is the bottom tension. If the stitch looks bad on the bottom, is the upper tension. The upper and lower threads play tug of war with each other.

Tension, tension, tension... This probably causes more problems than anything else. You need correct tension on the top and bottom threads, but you also must have correct tension on the quilt held between the bars. You should be able to gently rock the belly bar where the backing fabric is attached. This allows enough movement of your quilt layers for the needle to penetrate and make good stitches.

Before you start making adjustments to your machine, ask yourself, “What changed?” If your machine was stitching great and all of a sudden it has loopies on the back or puckers, “What changed?” Did you just change the bobbin? Did you just lift the take up bar? Did you lower the take up bar after finishing your last quilt? Did you recently change the needle? Did you just roll the quilt?

If the take up bar with the quilted portion of your quilt is too high, it will result in poor stitch quality. You need a finger tip space between the quilt and the machine bed. Higher will result in poor stitch quality. Lower and the quilt will create a drag on your machine’s movement.

Look at your bobbin. A sloppy wound bobbin will not create a good stitch. Make sure that the threads on the bobbin are snug and evenly wound. Check to see if there is a piece of lint in the bobbin case.

Tension Trouble Shooting Checklist

- Is the side tension lever down?
- Have I oiled my machine regularly?
- Is the quilt too tight on the frame?
- Is the thread coming off the cone freely?
- Has your thread jumped out of the tension discs?
- Check your threading. Has anything been missed or has the thread flipped itself around something, increasing your tension?
- Is the hopping foot too high or too low?
- Is your take up bar too high? Did you lower the take up bar after your last quilt?
- Do you need to change your needle?
- Is your needle in properly?

Top Thread Breaking

- Check to see that your thread is coming off the spool freely. The thread guide is centered over the spool and has not developed any burrs or catches.
- Check to see if the thread has looped itself around the spool pin.
- Check to see if the needle is in correctly, with the scarf facing the back of the machine.
- Have you recently changed the needle? Is it as high as it will go in the needle bar?

Eyelashes

Eyelashes on the back of the quilt can be caused by too little top tension. Turn the thread tension disk clockwise $\frac{1}{4}$ turn. Make small adjustments. Repeat until stitch quality is good. Remember the upper and lower thread play tug of war with each other.

Loose Top Stitch

Is the tension lever handle down? It lowers the hopping foot and applies the tension disc. Is the bobbin thread inserted in the slot of the bobbin case? Adjust the tension disc small turns clock wise. Repeat until stitch quality if good.

Quilt Top Puckers

Is your backing fabric stretched too tight? While the backing fabric needs to lie flat and without wrinkles, stretching it too tight can make the quilt top pucker. After stitching and releasing the backing fabric, the top will pucker.

Is the top tension too tight? Adjust the tension disc small turns counter clockwise. Repeat until stitch quality is good.

Stitches are Skipped

Skipped stitches leave needle holes without thread, while large and small stitches in regulated mode means the encoders are not picking-up the signal of your movements because of lint or thread stopping or slowing the reading.

First, check to see that your machine is threaded correctly. Look at the check spring. Does the thread lay in the check spring? When properly threaded, the check spring will move up and down as the machine is stitching and the thread is flowing freely.

Check the needle. Be sure it is all the way up into the shaft and the scarf is toward the back. If it has been used for some time, replace the needle. A blunt needle will make a popping sound as it penetrates the quilt sandwich.

Machine Drags Making it Difficult to Move

Check to make sure the quilt on the take up bar is not dragging on the bed of the machine. A finger tip distance between the take up bar and the bed of the machine is all that is necessary. Elevating the take up bar too high can cause loopies on the back. Look for lint or thread that might be snagging as you move the machine.

Difficult to Control the Movement of the Machine

Check for lint or other debris on the track and bars. Sometimes the smallest pieces of thread create the biggest headaches.

3-9 Check Spring Replacement/Tension Knob

From time to time you may need to replace the Check Spring. This series of photos will help.



Figure 3-84
Tension assembly with broken spring. (old tension knob)



Figure 3-85
Tension assembly with good spring (new tension knob)



Figure 3-86
Screw on inside of machine
LOOSEN ONLY. DO NOT REMOVE



Figure 3-87
Remove assembly from machine.
Be careful with release pin



Figure 3-88
Machine with tension assembly removed



Figure 3-89
Tension assembly out of machine
DO NOT LOSE PIN



Figure 3-90
Loosen screw only
DO NOT REMOVE



Figure 3-91
Remove tension assembly from barrel



Figure 3-92
Tension assembly and barrel



Figure 3-93
Remove spring



Figure 3-94
Spring removal



Figure 3-95
Spring removed

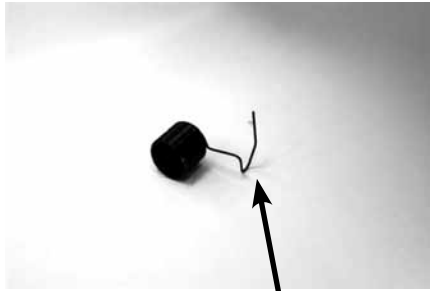

Figure 3-96
New spring, This tail is what was broken



Figure 3-97
Insert the new spring



Figure 3-98
Twist while inserting the new spring



Figure 3-99
New spring in place



Figure 3-100

Insert the tension assembly back into the barrel. **REMEMBER DO NOT LOSE THE PIN**



Figure 3-101

Insure that you are all the way in



Figure 3-102

Give the tension assembly a twist until you feel resistance on the check spring



Figure 3-103

Tighten screw. Make sure the pin is still there.



Figure 3-104

Place the assembly back into your machine



Figure 3-105

Once in, ensure that your check spring is at 11:00



Figure 3-106
Press in and notice the tension disk opens



Figure 3-107
Release and the disk will close; this is the proper place for your tension assembly



Figure 3-108
Tighten screw on your machine



Figure 3-109
Tension assembly back in place with new check spring at 11:00



Figure 3-110
For fine adjustment of check spring insert screwdriver turn clockwise for more tension

Timing Between Needle and Rotating Hook

Remove the two needle plate screws from your machine.

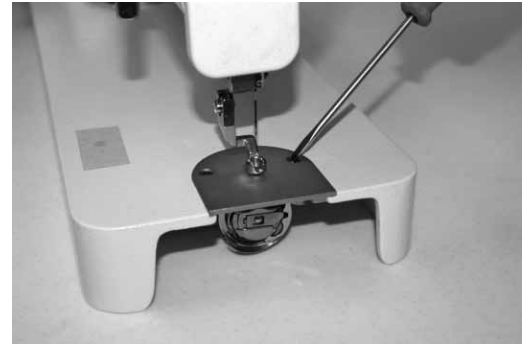

You will also need to remove the three face plate screws.



The protecting flange of the position bracket A should be engaged in the notch B of the bobbin case holder. D is the set screw to adjust hook timing. (The photo on the right is the actual machine as shown in the drawing.) The drawing and the photo show correct timing.

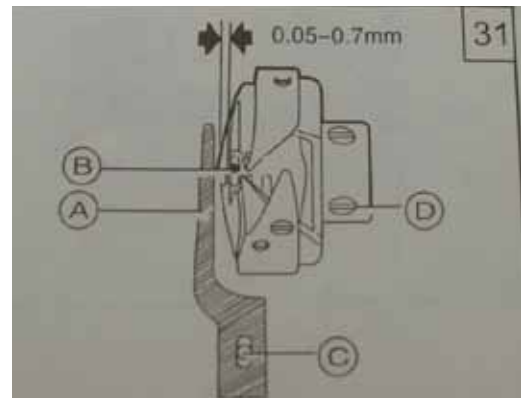

Turn the hand wheel to locate the needle at its lowest position. **Note: Correct needle position is when you can see a small portion of the eye of the needle. This picture shows correct location.**



Loosen needle bar connecting screw A. This will allow you to raise and lower needle bar for correct location. **Note: Check all photos before making any adjustments.**

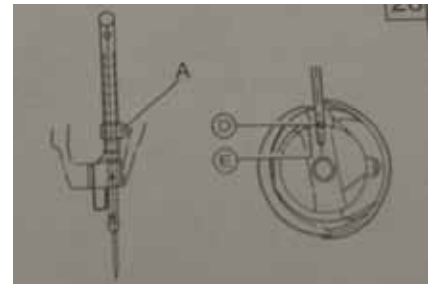

Adjusting rotating hook point timing with needle:
Turn the hand wheel counter clockwise to locate the needle to its lowest position. At the lowest position, turn the hand wheel to raise the needle 2.5 mm (1/8"). Hook point should be just above the eye of the needle.

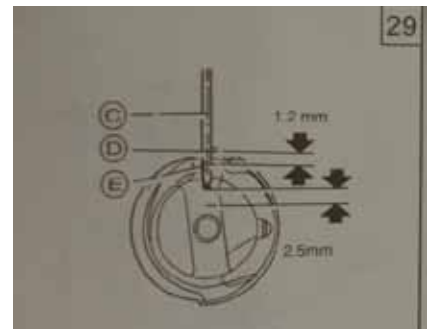

Hook Point

This picture shows the needle bar and the hook point at the proper location after needle bar rise.

Note: If the hook point is not in this location, reference drawing 31. Loosen screw D. There are three screws. At this point, the rotating hook can be moved freely on its shaft to locate proper timing.

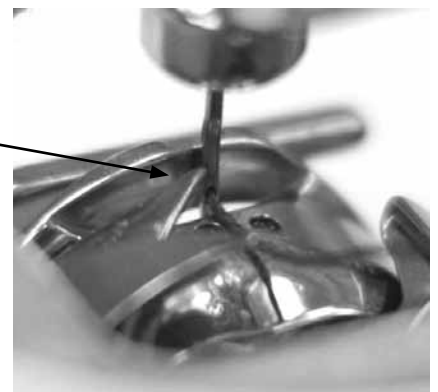

When adjusting the rotating hook point timing, also note that clearance between the notch bottom of needle D and hook point C must be maintained. The hook cannot rub against the needle. Also see drawing 31 (on page 26) for a better view.

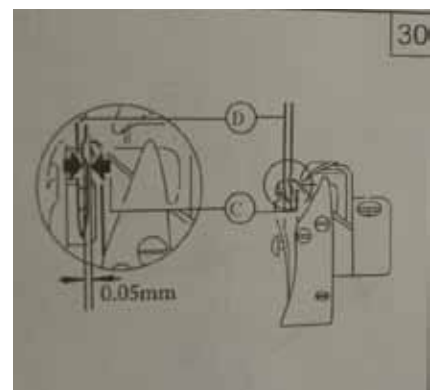

Quilter's Pro

1.800.401.8151

www.sewingmachinesplus.com

Proud to be a **LEADING** manufacturer of long arm quilters in the U.S.