



2610ZW

INDUSTRIAL SEWING MACHINE

INSTRUCTION MANUAL AND PARTS BOOK

menu

parts breakdown illustration

A. Arm bed components.....	1
B. upper shaft.vertial shaft.taje-up machanism.....	1
C. swaying needle.Lower shaft. Rotating shuttle shaft machanism...	3
D. sewing line adjusted machanism...	3
E. lower Feed lifting mechanism.....	5
F. Feed lifting mechanism.....	5
G. top Feed machanism components...	7
H. Multi points sewing mechanism.....	7
I. Lubrication mechanism.....	9
J. Accessories.....	9

operation instruction

one、 item of all components.....	11
two、 sewing machine specification.....	12
three、 installation.....	12
1. oil disk.....	12
2. knee-control component.....	12
3. rubber cushions.....	13
4. Triangle Shock Pad.....	13
5. ear Shock Pad.....	13
6. knee lifter complying bar.....	13
7. The machine head.....	13
8. Pillow of the head.....	13
9. U type belt cover.....	13
10. C type belt cover.....	13
11. Triangle belt cover	13
12. D type belt cover.....	13
Four、 adjust sewing machine	14
1. Installing the needle.....	14
2. removing the cap and adjust the tension.....	14
3. Winding the lower thread.....	14
4. Threading the upper thread and adjust.....	15
5.adjusting presser foot pressure.....	15
6. adjusting the stitch length.....	15
7. adjusting the height of feed dog and Tilt.....	15
Five、 Trouble causes and solutions.....	16

A. Arm bed components

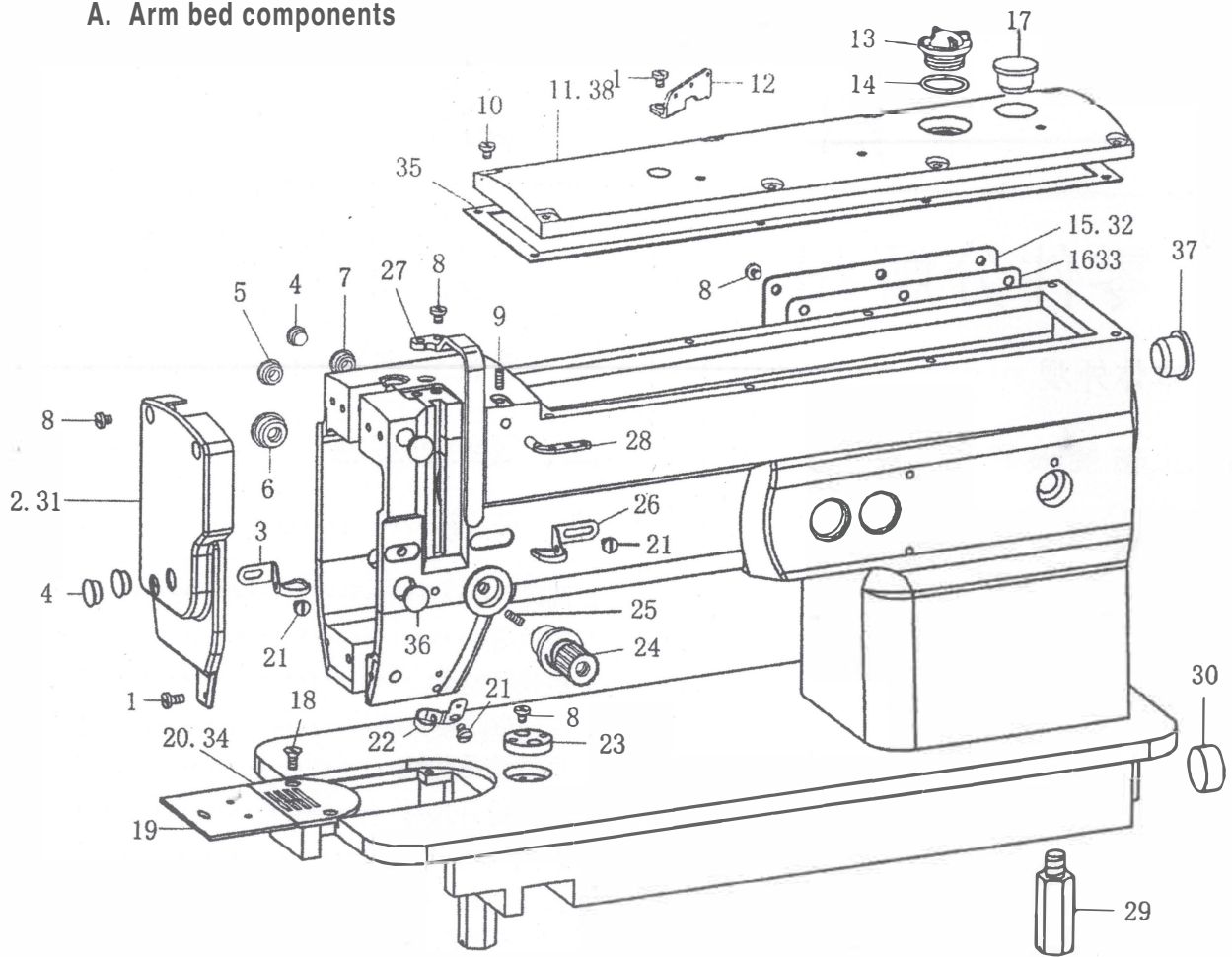

B. upper shaft. vertical shaft. take-up mechanism

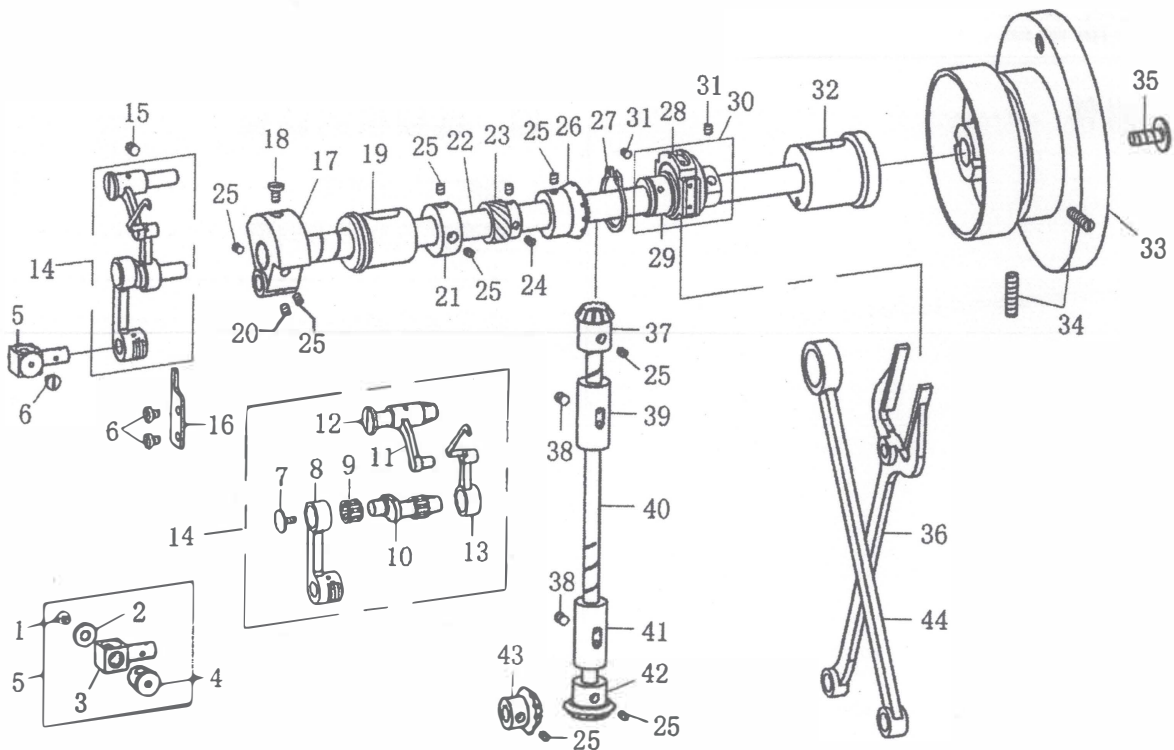

A. Arm bed components

(Memo:#01 for 1530 #02 for 2530)

Memo	Ref No.	Part NO.	item	Amt	Req	Memo	Ref No.	Part NO.	item	Ref No.
	01	Y43-D8X6	screw 11/64-40X5	3	1	20	1530A-20	sliding plate complete		1
01	02	1530A-2	fale plate	1		21	Y35-D7X7	screw 9/64-40X7		3
	03	1530A-3	threadcam DY2-29	1		22	#28	threadcam		1
	04	P11.8X5	rubber plug (D=11)	4		23	1530A-23	holder DY2-22		1
	05	p10.8x4	rubber plug (D=10)	3		24	1530A-24	Cramping group DY2-901		1
	06	P15.8X6	rubber plug (D=14.5)	1		25	Y59-D0X7	scew 15/64-28X7		3
	07	P8.8X5	rubber plug (D=8)	1		26	1530A-26	threadcam		1
	08	Y43-D7X7	screw 11/64-40X7	8		27	1530A-27	thread eyelet		1
	09	Y43-D0X6	screw 11/64-40X6	8		28	#19	three thread eyelet		1
	10	Y43-D7X9	screw 11/64-40X9	8		29	1530A-29	bed leg		3
	11	1530A-11	upper corer	1		30	P24X7	rubber plug (D=23.5)		1
	12	1530A-12	upper three thread eyelet			31	2530A-31	fale plate		1
	13	1530A-13	oil screen complete	1	02	32	2530A-32	side plate		1
	14	0R-18	O-type ring	1	02	33	2530A-33	washer		1
01	15	1530A-15	side plate	1	02	34	2530A-34	needle plate		1
01	16	1530A-16	Washer	1		35	P13	rubber plug (D=12)		1
	17	P18.5	rubber plug	1		36	P8	rubber plug (D=7)		1
	18	#263	scew 11/64-40X7	2		37	P20X4	rubber plug		1
	19	1530A-19	sliding plate	1	02	38	2350A-38	upper cover		1

B. 1530. 2530 upper shaft. vertial shaft. taje-up machanism. (Memo:#01 for 1530 #02 for 2530)

Memo	Ref No.	Part NO.	item	Amt	Req	Memo	Ref No.	Part NO.	item	Ref No.
	01	1530B-1	scew 11/64-40X3.5	1		23	1530B-23	needle sewing drive gear(upper)		1
	02	1530B-2	washer	1		24	Y43-SD0X4	screw 11/64-40X4		2
	03	1530B-3	needle crank	1		25	Y63-SD0X6	screw 1/4-40X6		10
	04	1530B-4	needle crank	1		26	#116	bevel gear		1
	05	1530B-5	needle crank complete	(1		27	S26	C thrust collar		1
	06	Y43-D8X6	screw 11/64-40X6	3		28	#129	Feed "Y" connecting asm		1
	07	1530B-7	screw	1		29	1530B-29	eccentric cam DY4-904B		1
	08	1530B-8	needle bar crank	1		30	1530B-30	eccentric cam complete DY4-904	(1	
	09	08X12X08	needle bearing	2		31	Y59-D0X7	screw 15/64-28X7		1
	10	1530B-10	thread take-up crank	1		32	#133	main shaft thrust collar (right)		1
	11	1530B-11	take-up thread con	1		33	1530B-33	hand wheel 33B-69		1
	12	1530B-12	shaft	1		34	Y59-D0X15	screw 15/64-28X15		2
	13	1530B-13	take-up thread	1		35	#136	screw 11/32-28X13		1
	14	1530B-14	take-up thread complete	(1		36	1530B-36	feed holder		1
	15	Y59-D0X15	screw 15/64-28X15	1		37	#117	vertial shaft upper gear		1
	16	1530B-16	rail	1		38	Y59-D0X11	screw 15/64-28X11		2
	17	1530B-17	needle bar crank	1		39	#119	vertial shaft thrust collar		1
	18	#105	screw 9/32-28X10	1		40	1530B-40	vertial shaft		1
	19	#103	front bushing	1		41	#120A	vertial shaft thrust collar D=17.5		1
	20	Y63-D0X5	screw 1/4-40X5	1		42	#124	vertial shaft lower gear		1
	21	#102	upper shaft retainer	1		43	#125	lower shaft right gear		1
	22	1530B-22	arm shaft	1		44	1530B-44	toothed connecting bar 33B-74		1

C. swaying needle.Lower shaft. Rotating shuttle shaft mechanism

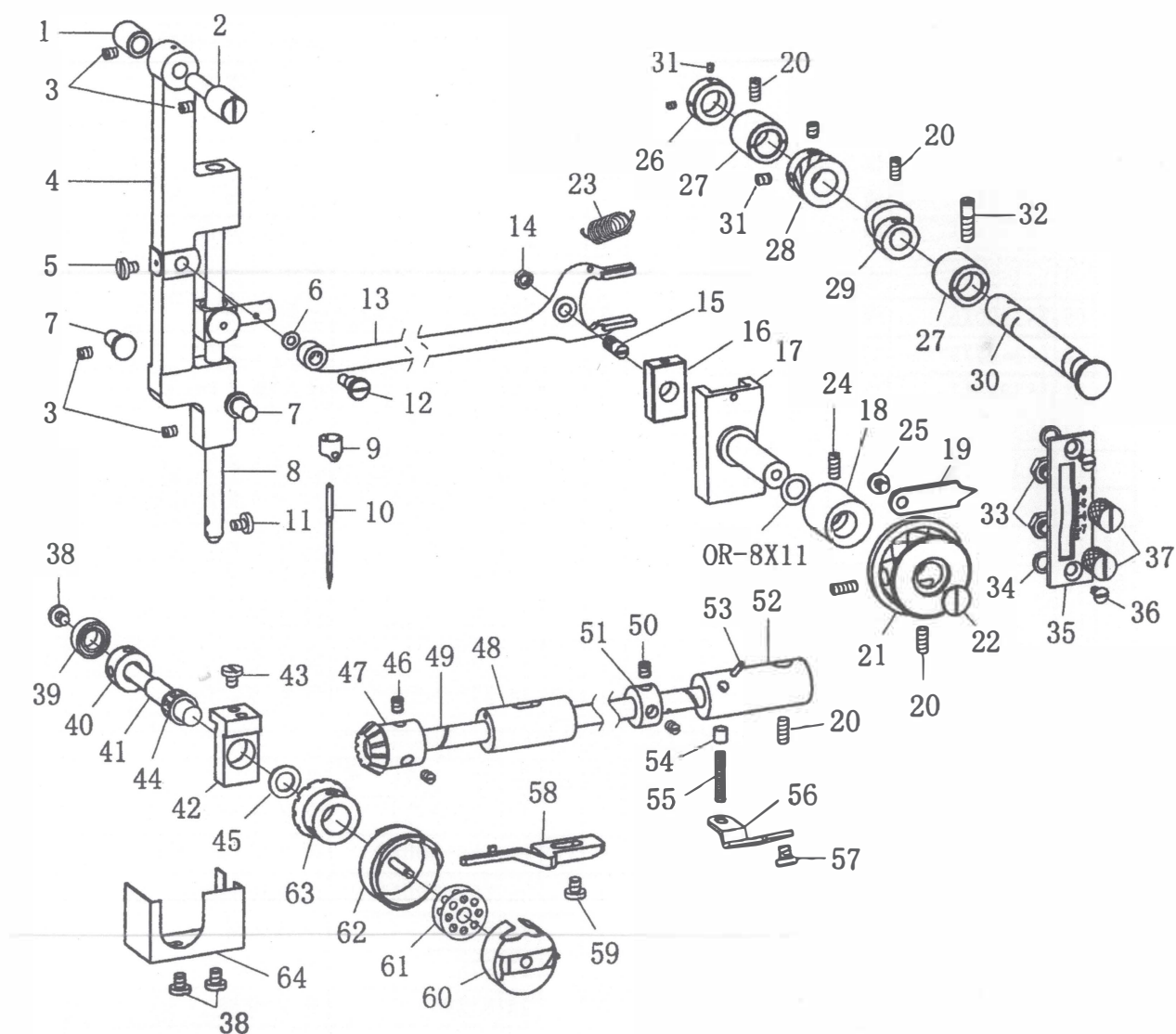

D. sewing line adjusted mechanism

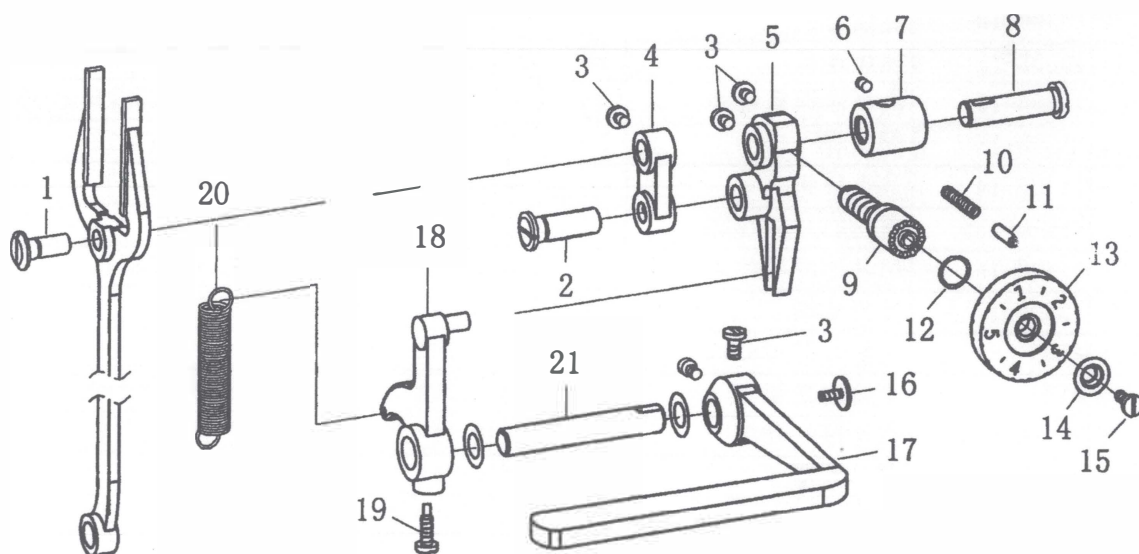

C. 1530.2530 swaying needle.Lower shaft.Rotating shuttle shaft machanism (Memo:#01 for 1530 #02 for 2530)

Memo	Ref No.	Part NO.	item	Amt Req	Memo	Ref No.	Part NO.	item	Ref No.
	01	1530C-1	shaft of swaying rack screw	1		33	1530C-33	Nut 11/64-40X3	2
	02	1530C-2	shaft of swaying rack	1		34	1530C-34	washer DY8-201	2
	03	LW-M4X4	screw M4-0.75X4	6		35	1530C-35	sewing width showing plate	1
	04	1530C-4	swaying rack of needle bar	1		36	1530C-36	screw 11/64-40X10	2
	05	Y43-D8X6	screw 11/64-40X6	1		37	1530C-37	screw 11/64-40	2
	06	W5X10X1	washer W5X10X1	1		38	Y35-D6X6	screw 9/64-40X6	3
	07	1530C-7	swaying rack bush	2		39	696ZZ	shaft696	1
	08	1530C-8	needle bar	1		40	1530C-40	retainer of rotating shuttle shaft	1
	09	91C-38	thread finger	1		41	1530C-41	rotating shuttle shaft	1
	10	DPX5	needle bar	1		42	1530C-42	locating plate rotating shuttle	1
	11	Y3144-D4X4.5	screw 1/8-44X4.5	1		43	LT-M4X10	screw M4-0.7X10	2
	12	1530C-12	eccentric pin	1		44	08X12X08	needle bearing	1
	13	1530C-13	fork (lower)	1		45	W8X16X1	washer W8	(1
	14	Y71-LM11X4	Nut 9/32-28X4	1		46	Y63-SD0X6	screw 1/4-40X6	2
	15	1530C-15	shaft of fork (lower)	1		47	1530C-47	lower shaft gear	1
	16	1530C-16	sliding block	1		48	#119	left sleeve of lower shaft D=17	1
	17	1530C-17	sliding block support	1		49	1530C-49	hook driving shaft	1
	18	1530C-18	sleeve DY8-155	1		50	Y59-D0X5	screw 15/64-28X5	2
	19	1530C-19	stitch width pointer	1		51	#122	lower shaft retainer	1
	20	Y59-D0X7	screw 15/64-28X7	4		52	1530C-52	hook driving shaft thrust collar(right)	1
	21	1530C-21	stitch width knob	1		53	1530C-53	oil tube	1
	22	Y4728-D14X8	screw 3/16-28X8	1		54	1530C-54	screw 15/64-28X5	1
	23	1530C-23	spring	1		55	#160	spring	1
	24	Y59-D0X11	screw 15/64-28X11	1		56	1530C-56	frame	1
	25	#263	screw 11/64-40X7	1		57	Y59-D8X10	screw 15/64-28X10	1
	26	1530C-26	retainer of swaying needle shaft	1		58	1530C-58	rotating book position finger	1
	27	1530C-27	sleeve of swaying needle	2		59	Y43-D9X9	screw 11/64-40X9	1
	28	1530C-28	swaying needle gear (lower)	1		60	1530C-60	bobbin	1
	29	1530C-29	eccentric cam	1		61	1530C-61	bobbin case	1
	30	1530C-30	swaying needle shaft	1		62	1530C-62	hook	1
	31	Y43-SD0X4	screw 11/64-40X4	4		63	1530C-63	gear	1
	32	1530C-32	screw 15/64-28	4		64	1530C-64	butter box	1

D. 1530.2530 sewing line adjusted machanism (Memo:#01 for 1530 #02 for 2530)

Memo	Ref No.	Part NO.	item	Amt Req	Memo	Ref No.	Part NO.	item	Ref No.
	01	1530D-1	shaft	1		12	OR-14	O ring	1
	02	#152	feed regulaotor screw	1		13	1530D-13	dial number	1
	03	Y59-D8X10	screw 15/64-28X10	5		14	1530D-14	washer	1
	04	1530D-4	stitch adjustment rod	1		15	Y4728-D8X15	screw 3/16-28X15	5
	05	1530D-5	feed regulator	1		16	Y4728-D14X8	screw 3/16-28X8	5
	06	Y59-D0X11	screw 15/64-28X11	1		17	#167	bartacking lever	1
	07	#158S	feed regulator bush	1		18	#906	bartacking srank	1
	08	#159	feed regulator hinge pin	1		19	#171	screw 15/64-28X10	1
	09	1530D-9	feed regulator screw	1		20	#172	spring	1
	10	#160	spring for stopper pin	1		21	#169	bartaking lever shaft	1
	11	#162	stpper pin	1					1

E. lower Feed lifting mechanism

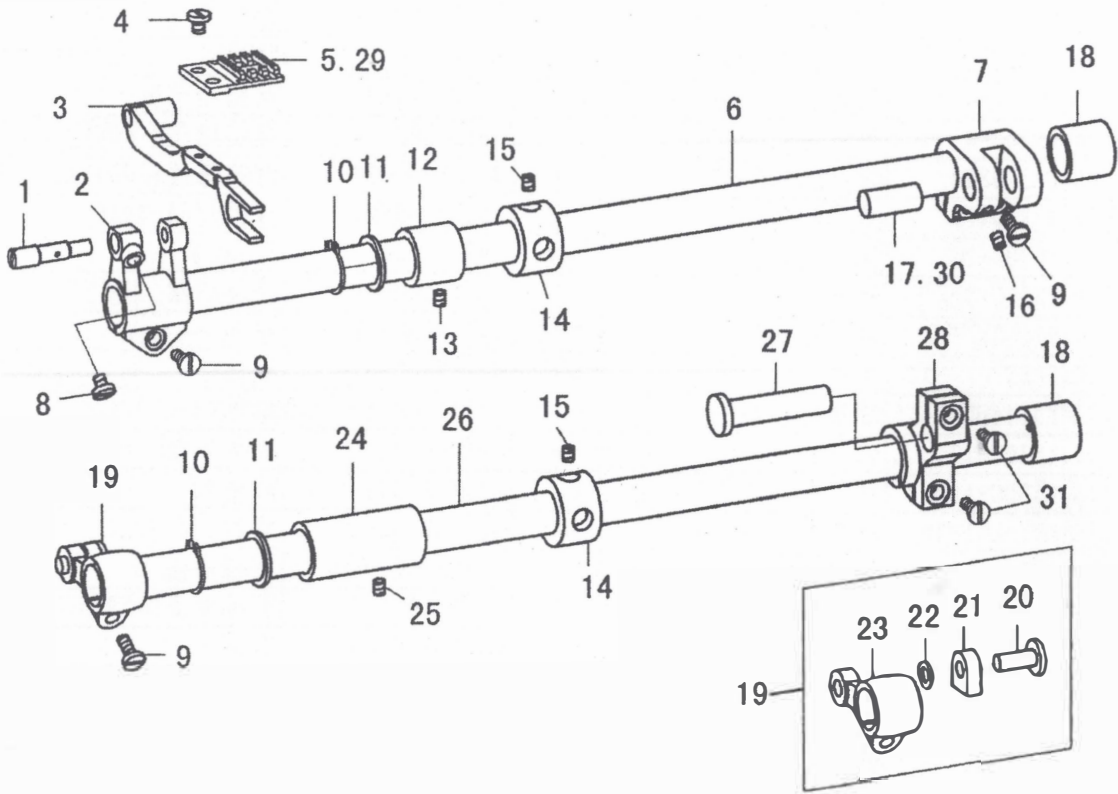

F. sewing line adjusted mechanism

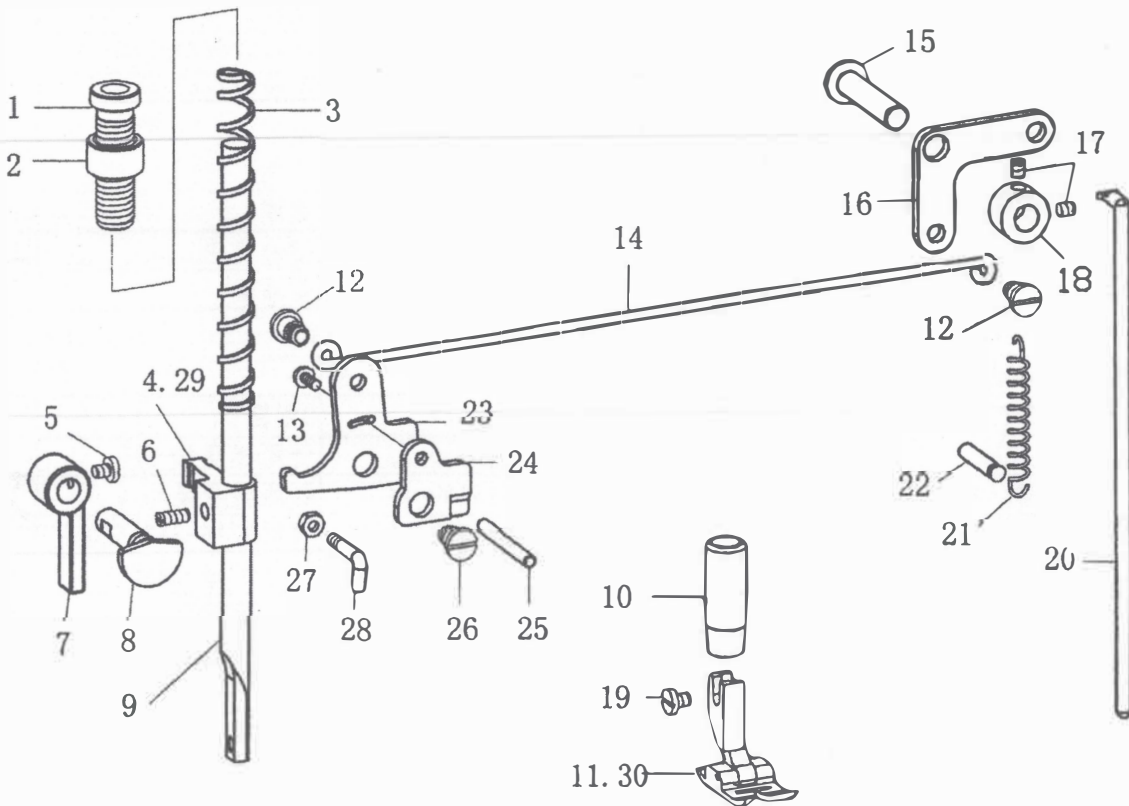

E. 1530. 2530 lower Feed mechanism components

(Memo:#01 for 1530 #02 for 2530)

Memo	Ref No.	Part NO.	item	Amt Req	Memo	Ref No.	Part NO.	item	Ref No.
	01	1530E-1	feed holder shaft	1	01	17	#226	shaft	1
	02	1530E-2	feed crank	1		18	1530E-18	feed driving shaft bushing(right)	2
	03	1530E-3	feed holder shaft	1		19	1530E-19	feed crank group	(1
	04	Y3144-D5X6	screw 1/8-44X6	2		20	1530E-20	moving crank group	1
01	05	1530E-5	feed dog	1		21	1530E-21	moving crank	1
	06	1530E-6	material feeding shaft	1		22	W6X10	washer W6	1
	07	#222	feed driving shaft crank (right)	1		23	1530E-23	feed crank group	1
	08	Y43-D7X7	screw 11/64-40X7	1		24	1530E-24	feed lifting shaft bushing(left)	1
	09	Y43-D8X13	screw 11/64-40X13	3		25	Y59-D0X11	screw 15/64-28X11	1
	10	S-15	s type	2		26	1530E-26	toothed shaft	1
	11	W15X20	washer W15	2		27	1530E-27	feed lifting shaft bushing(left)	1
	12	1530E-12	feed rocker shaft(left)	1		28	1530E-28	feed lifting shaft crank (right)	1
	13	Y59-D0X7	screw 15/64-28X7	1	02	29	2530E-29	material feeding shaft	1
	14	#211	thrust collar	2	02	30	2530E-30	shaft	1
	15	Y63-SD0X6	screw 1/4-40X6	4		31	Y4728-D8X15	screw 3/16-28X15	2
	16	Y43-D0X6	screw 11/64-40X6	1					

F. 1530. 2530 Feed lifting mechanism

(Memo:#01 for 1530 #02 for 2530)

Memo	Ref No.	Part NO.	item	Amt Req	Memo	Ref No.	Part NO.	item	Ref No.
	01	#184	screw	1		16	1530F16	lever (right)	1
	02	42C-4	nut 10-143	1		17	Y59-D0X5	screw 15/64-28X5	2
	03	#187	spring	1		18	#122	washer	1
01	04	1530F-4	guide for presser bar	1		19	Y35-D7X7	screw 9/64-40X7	1
	05	Y43-D7X7	screw 11/64-40X7	1		20	1530F-20	sconnecting rod L=200	1
	06	Y59-D0X7	screw 15/64-28X7	1		21	1530F-21	spring	1
	07	1530F-7	presser foot lift bar	1		22	1530F-22	Pin	1
	08	1530F-8	presser foot lift	1		23	1530F-23	lever (left)	1
	09	1530F-9	presser bar	1		24	1530F-24	thread releasing cam	1
	10	#202	dushing for presser bar	1		25	1530F-25	thread releasing lever	1
01	11	1530F-11	presser	1		26	1530F-26	SM5/64-28X7.5	
	12	1530F-12	screw 3/16-28X5 341F-25	2		27	Y35-LM6X3	Nut 9/64-40X3	1
	13	Y43-D9X7	screw 11/64-40X7	1		28	1530F-28	thread guide	1
	14	1530F-14	knee lifter drawing bar	1	02	29	2530F-29	Guide for presser bar	1
	15	1530F-15	knee lifter drawing lifter bar	1	02	30	2530F-30	presser foot	1

G. top Feed mechanism components

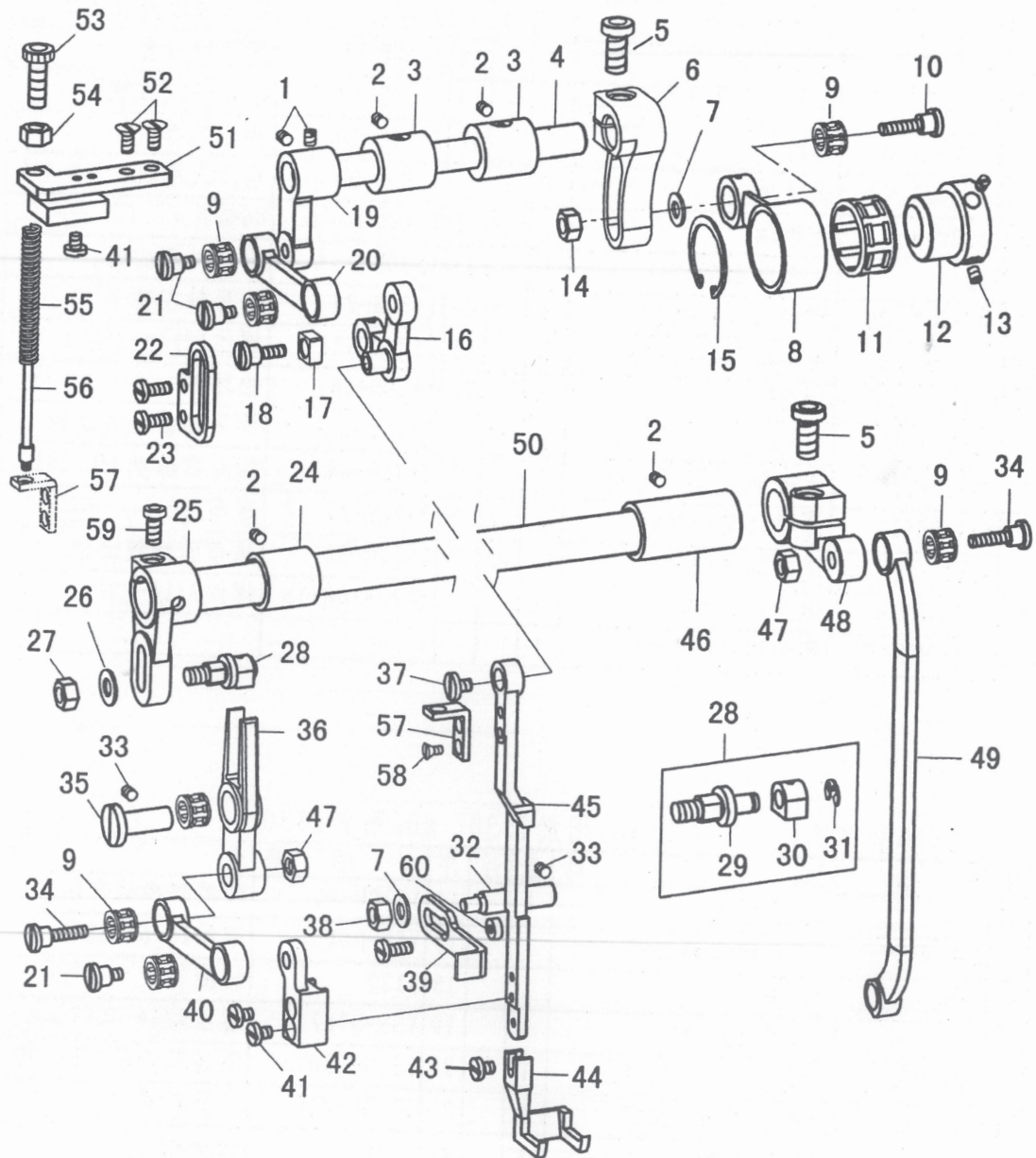

H. Multi points sewing mechanism

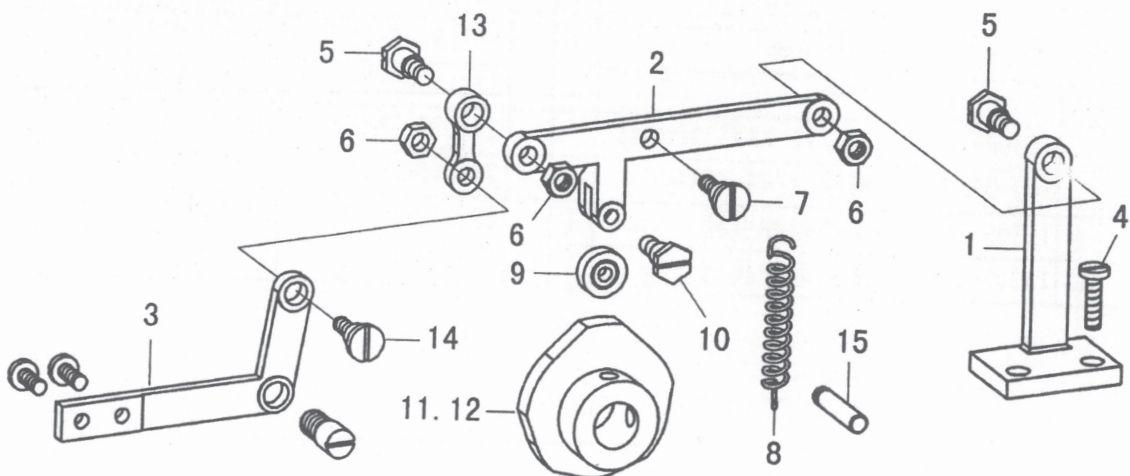

G. 2530 top Feed mechanism components

(Memo:#01 for 1530 #02 for 2530)

Memo	Ref No.	Part NO.	item	Amt Req	Memo	Ref No.	Part NO.	item	Ref No.
	1	LW-M6X5	screw M6X5	2		31	E-4	E-4 type	1
	2	Y43-D0X6	screw 11/64-40X6	4		32	2530G-32	shin	1
	3	2530G-3	bushing GY8-155	2		33	Y59-D0X7	screw 15/64-28X7	2
	4	2530G-4	presser foot lift shaft	1		34	2530G-34	screw 1/4-40X16 37E-34	2
	5	LT-M6X20	screw M6X20	2		35	2530G-35	Pin DY8-208	1
	6	2530G-6	link adjusting crank	1		36	640E-63	fork lever 37E-36	1
	7	W6X12	washer W6	2		37	Y4728-D12X7	3/16-28X7 810-165	1
	8	2530G-8	link complete	1		38	Y59-LM9X3	Nut 15/64-28X3	1
	9	8X12X8	needle bearing	6		39	2530G-39	presser plate	1
	10	2530G-10	screw M6	1		40	2530G-40	link of walking foot	1
	11	24X28X13	needle bearing	1		41	Y35-D6X6	Nut 9/64-X6	2
	12	2530G-12	eccontic cam	1		42	2530G-42	holder for walking foot bar	1
	13	Y63-SD0X6	screw 1/4-40X6	2		43	Y35-D7X7	screw 9/64-40X7	1
	14	KM10X6-M6	Nut M6	1		44	2530G-44	walking foot	1
	15	S-24	S-24 type	1		45	2530G-45	walking foot lever	1
	16	2530G-16	Outer plate suspension support	1		46	640E-46	rear bushing	1
	17	2530G-17	block	1		47	Y63-LM10X5	Nut 1/4-40X5	2
	18	2530G-18	screw 3/16-28X7	1		48	2530G-48	pear crank	1
	19	2530G-19	crank	1		49	2530G-49	link of walking foot	1
	20	2530G-20	feed crank connecting rool 37E-20	1		50	640E-43	presser foot sewing shaft L=360	1
	21	2530G-21	screw 1/4-40X6 37E-21	3		51	2530G-51	guide plate	1
	22	2530G-22	set plate	1		52	#263	screw 11/64-40X7	2
	23	Y43-D7X7	screw 11/64-40X7	2		53	2530G-53	screw DY8-151	1
	24	2530G-24	front bushing	1		54	Y71-LM11X4	Nut 9/32-28X4L	1
	25	640E-57	pear crank	1		55	2530G-55	spring DY8-170	1
	26	W6. 5X13	washer W6.5	1		56	2530G-56	guidepin DY8-171	1
	27	Y6324-LM10X5	nut 1/4-24X5	1		57	2530G-57	set plate	1
	28	2530G-28	crank shaft complete	(1		58	#255	screw 9/64-40X7	2
	29	2530G-29	crank shaf	1		59	YT-M6X14	screw M6X14	1
	30	2530G-30	crank pin	1					

H. Multi points sewing mechanism

(Memo:#03 for 3 points #04 for 4 points)

Memo	Ref No.	Part NO.	item	Amt Req	Memo	Ref No.	Part NO.	item	Ref No.
	01	1534H-1	wheel lock support	1		08	1534H-8	spring	1
	02	1534H-2	wheel rod	1		09	624ZZ	shaft	1
	03	1534H-3	connecting bar	1		10	91C-9	screw M4	1
	04	LT-M6X12	screw M6X12	2	03	11	1533H-11	3 points sewing eccentric team	1
	05	1534H-5	Nut 3/16-32 78L2-21-4	2	04	12	1534H-12	4 points sewing eccentric team	1
	06	Y4732-LM8X4	Nut 3/16-32X4	3		13	1534H-13	active bar 78L2-21-3	1
	07	#188-1	screw 3/16-28	1		14	1534H-14	screw 3/16-32 #267	1

I. Lubrication mechanism

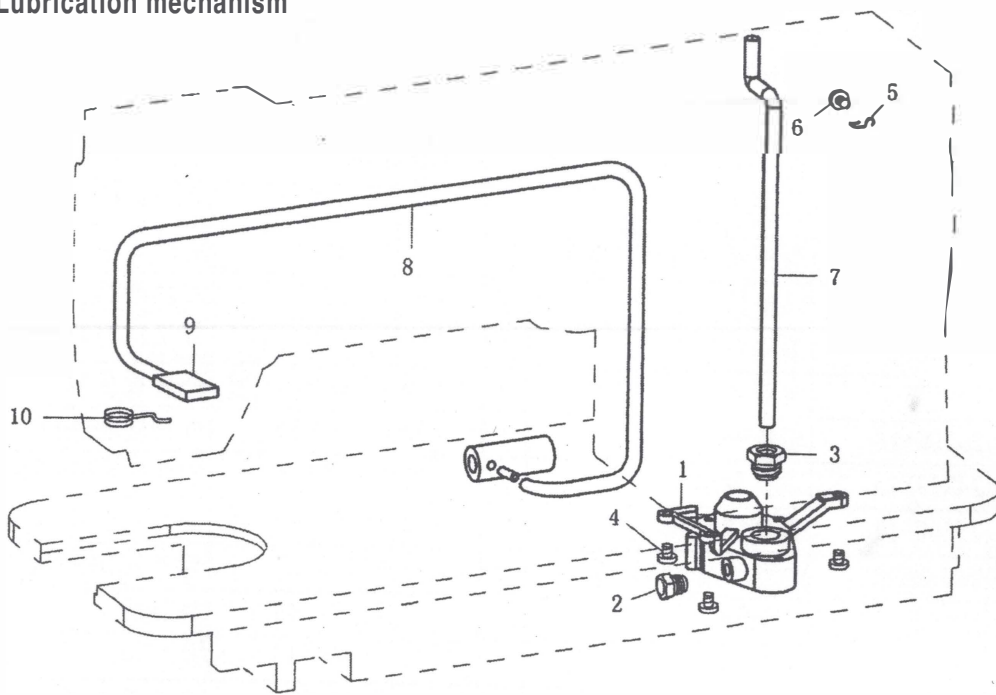

J. Accessories

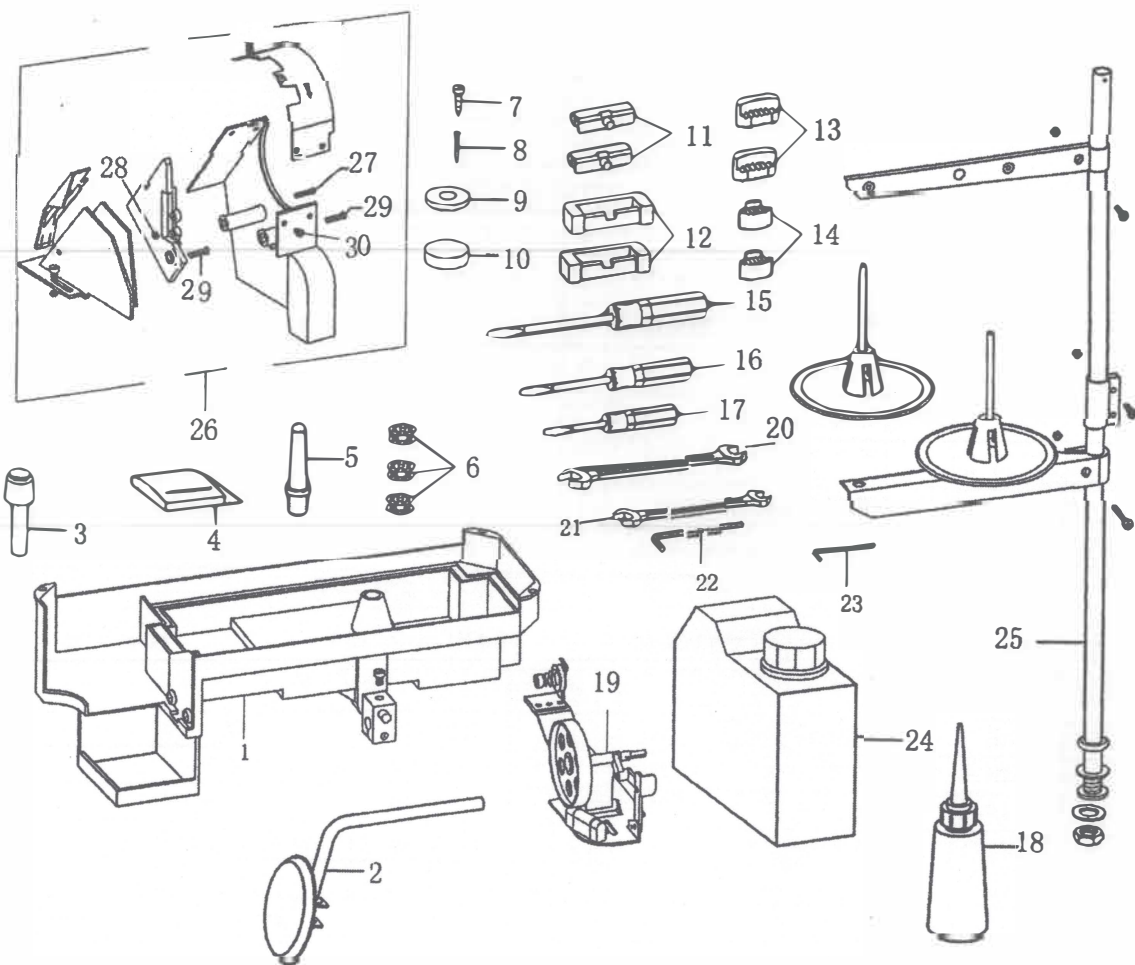

I. Lubrication mechanism

(Memo:#01 for 1530 #02 for 2530)

Memo	Ref No.	Part NO.	item	Amt Req	Memo	Ref No.	Part NO.	item	Ref No.
	01	1530J-1	oil pump body	1		06	1530J-6	Y43-D8X6	1
	02	1530J-2	screw 11/32-28 G-52	1		07	1530J-7	oil pipe for arm shaft	1
	03	1530J-3	screw 11/32-28 G53	1		08	1530J-8	oil returning pipe	1
	04	Y43-D8X13	screw 11/64-40X13	3		09	1530J-9	flet pouch for return oil filter	1
	05	1530J-5	spring for oil pipe	1		10	1530J-10	spring for oil felt	1

J. Accessories

(Memo:#01 for 1530 #02 for 2530)

Memo	Ref No.	Part NO.	item	Amt Req	Memo	Ref No.	Part NO.	item	Ref No.
	01	1530K-1	oil reseroir complete	1		16		screwdriver(M)	1
	02	1530K-2	knee lift complete	1		17		screwdriver(S)	1
	03	1530K-3	knee lifter prop bar	1		18		oiler	1
	04	DPX5	needle	4		19		threadwinding component	1
	05	#811	machine head pole	1		20		spander 12X14	1
	06	1530C-61	bobbin	3		21		spander 10X12	1
	07	M5. 5X25	screw	4		22		Allen wrench 5mm	1
	08		nail	4		23		Allen wrench 2mm	1
	09	W6X12	washer W6X12	4		24	1530K-20	oie cam	1
	10	1530K-10	magnet	1		25	FP-2L	thread stand	1
	11	1530K-11	machine hinge plateasm	2		26	1530K-22	belt coverasm	1
	12	1530K-12	washer (big)	2		27	YT-M4X18	screw M4X18	1
	13	1530K-13	washer (middle)	2		28	LM7X3-M4	Nut M4	1
	14	1530K-14	washer(small)	2		29	Y59-D8X10	screw 15/64-28X10	2
	15		screwdriver(L)	1		30	Y43-D8X6	screw 11/64-40X6	6

1530K-1:oil reservoir

Memo:#01 for 1530 #02 for 2530

Memo	Ref No.	Part NO.	item	Amt Req	Memo	Ref No.	Part NO.	item	Ref No.
	1	1530K-1-1	oil reseroir	1		9	E-9	E9 type	1
	2	LT-M6X12	screw M6X12	2		10	1530K-1-10	washer	1
	3	1530K-1-3	hinge pin	1		11	1530K-1-11	washer 8X15	1
	4	1530K-1-4	spring	1		12	1530K-1-12	screw SM5/16-28	1
	5	1530K-1-5	frame	1		13	1530K-1-13	oil pam	1
	6	Y59-LM10X4	Nut 15/64-28X4	2		14	YT-M5X12	screw M5X12	2
	7	Y59-D0X25	screw 15/64-28X25	2		15	LM8X3-M5	Nut M5X3	2
	8	#171	15/64-28X15 side 9	1		16	W5X10	washer W5X10	2

arm bed components

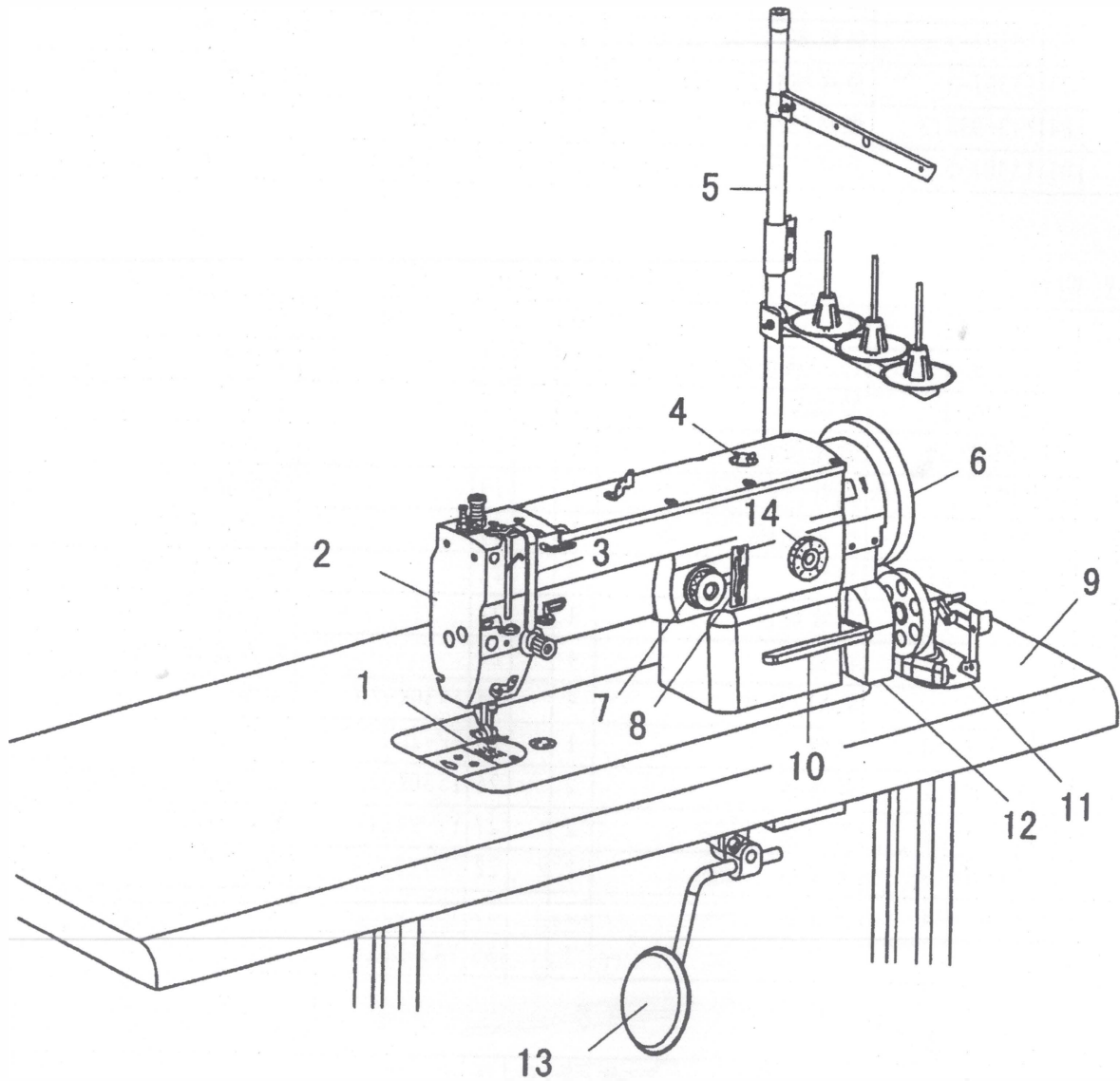

- | | | |
|--------------------------|----------------------------|----------------------|
| 1. needle plate | 2. panel | 3. thread eyelet |
| 4. oil screen complete | 5. thread stand | 6. upper wheel |
| 7. stitch width dial | 8. stitch width show plate | 9. table |
| 10. spanner | 11. thread-winding | 12. hand wheel cover |
| 13. knee lifter complete | 14. stitch length dial | |
-

two sewing machine specification

model item	1530	2530
sewing speed	2000spm	2000spm
stitch width	2 points	2 points
needle	Dpx5	Dpx17
take-up thread stroke	73	73
needle bar stroke	34	34
presser walking distance	-	3-7mm
presser foot lift	7mm	7mm
hook	horizontal hook(large)	horizontal hook(large)
application	light - middle	middle-heavy

installation

1. oil pan. (see figure 1) Fix the oil disk to the table.

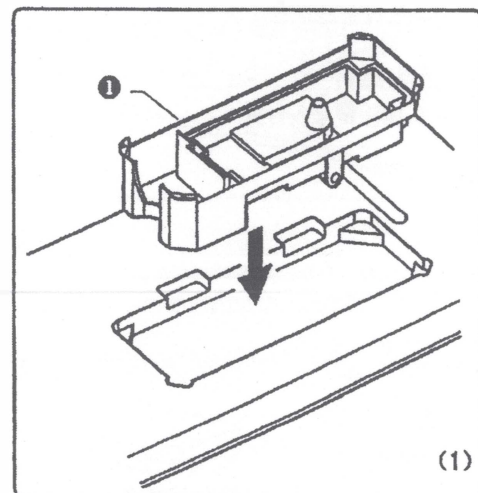

2. knee-control component
See figure 2
Place the knee lifter assembly onto the knee lifter bar on the oil pan. Loosen the screw (3) and (4), and adjust the knee lifter assembly (1) to the suitable position.

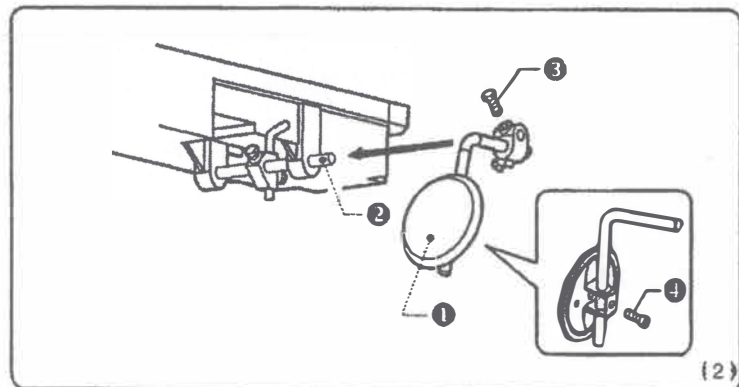

See figure 3

3. rubber cushions

Insert the two rubber cushions 1 into the notches in the work table, and then secure them with the two nails 2.

4. Rear Shock Pad

insert the two Rear Shock Pad into the two side of the oil pan, and then secure them with the two nails 4.

5. Front Shock Pad

insert the two front shock pad into the two side of the oil pan, and then secure them with the two nails 6.

6. knee lifter complying bar

Insert the knee lifter complying bar 7.

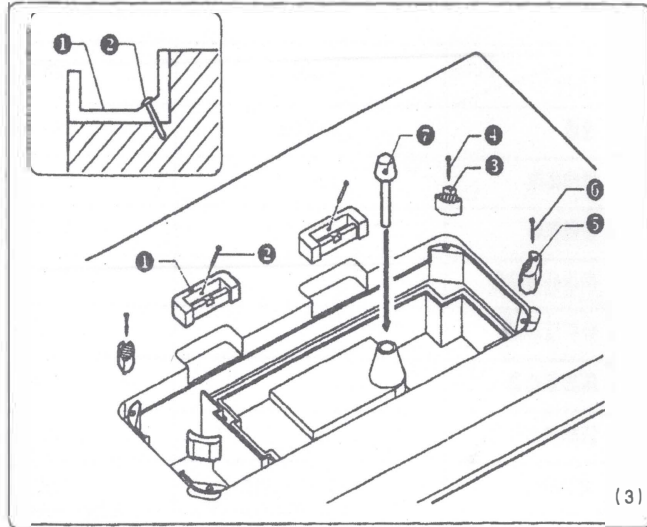

See figure 4

7. The machine head

Insert the hinge 1 onto the machine head, and then onto the rubber cushion 2.

8. machine support

Tap the machine support 3 into the table hole.

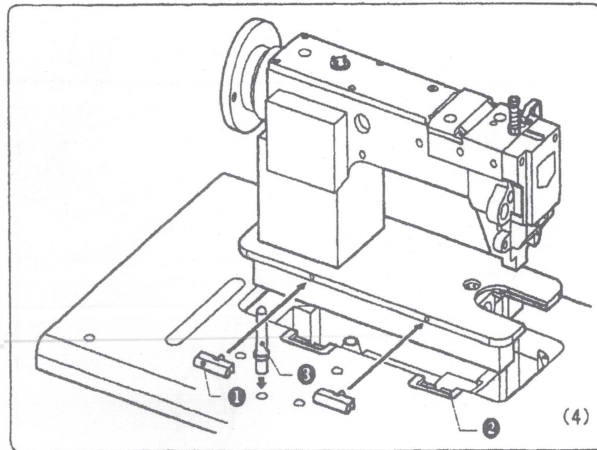

See figure 5

9. U type belt cover

Use the scrow 2 to fix the U type belt cover 1 to the machine head.

10. C type belt cover

Use the scrow 4 to fix the C 3 type belt cover to the machine head.
Use the scrow 5 to tighten the C type and U type belt cover.

11. Triangle belt cover

Tighten the U type belt cover and Triangle belt cover by screw 7 and nut 8.

12. D type belt cover

Insert the D type belt cover into the D type belt.

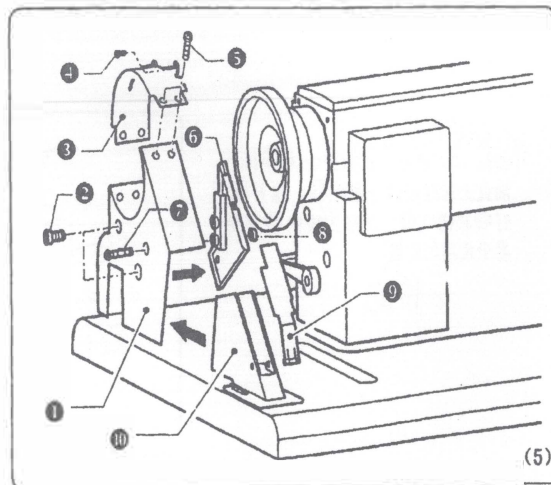

Four、adjust

1. Installing the needle:

See figure(6-1), Turn the machine hand wheel to move the needle bar to its highest position. Loosen the screw 2, hold the needles 1 with their groove facing inward, insert them all the way into the needle bars. And retighten the screws 2.

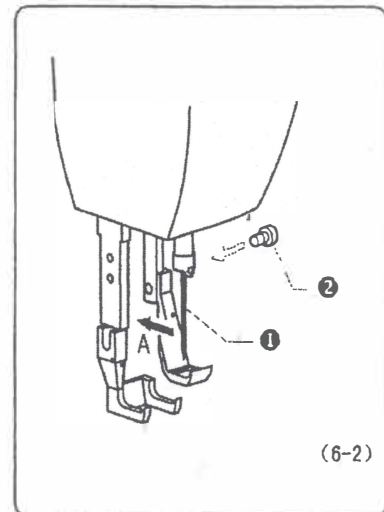
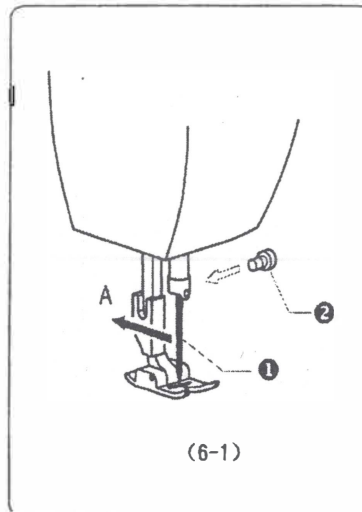

<2530>:

See figure(6-2), Turn the machine hand wheel to move the needle bar to its highest position. Loosen the screw 2, hold the needles 1 with their groove facing inward, insert them all the way into the needle bars. And retighten the screws 2.

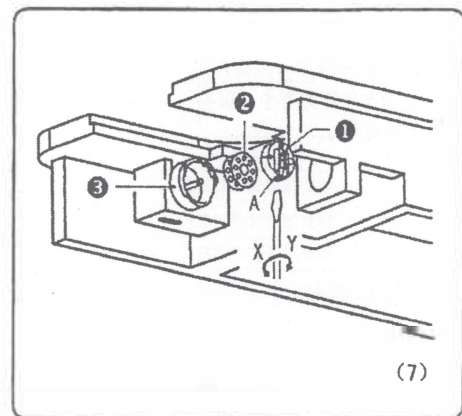

2. removing the cap and adjust the tension.

See figure(7)

<1> Removing the cap

pull the latch of the cap to remove. insert the bobbin into the cap. Insert the cap into the rotary hook.

<2> adjust the tension of the bottom thread

See figure, use screwdriver turn screw A ,X direction less tension, Y direction more tension.

3.Winding the lower thread

After connected the lower thread 1 as pic see figure 8 ,

Insert the thread through the eyelet then between the tension disks, wrap the thread around the bobbin. Push the lever forward so the wheel is touching the belt.

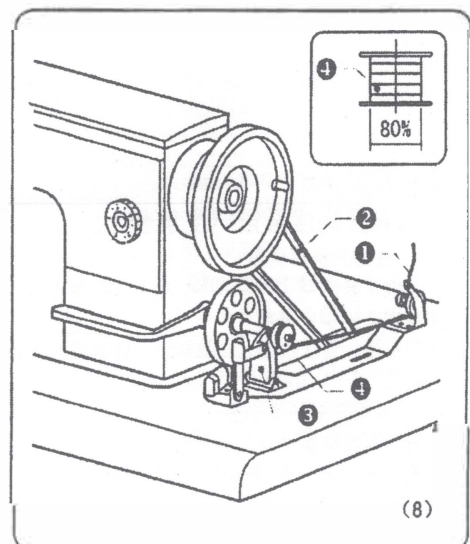

4. Threading the upper thread and adjust

See figure (9)

〈1〉 Threading the upper thread /

Weave the thread through the top upper eyelets as shown in the picture.

〈2〉 adjusting the thread surface

Turn the thread-running plate(2),X direction is more tension,Y direction is less tension.

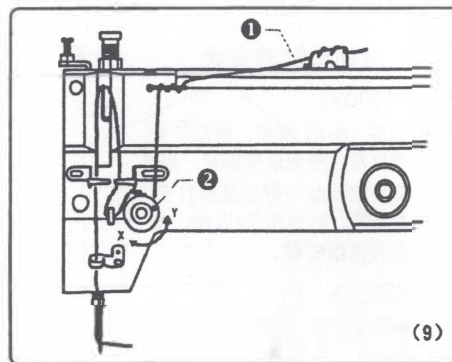

5.adjusting presser foot pressure

See figure (10)

〈1〉 adjusting out presser foot pressure

Turn the screw 1, A direction presser foot more pressure ,B direction presser foot less pressure, must fix the screw 2 after well adjusted.

〈2〉 adjusting inside presser foot pressure

Turn the screw 3, C direction presser foot more pressure ,

D direction presser foot less pressure, must fix the screw 4 after well adjusted.

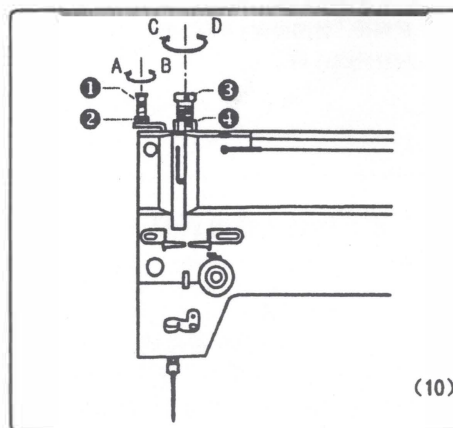

6. adjusting the stitch length

See figure (11)

The feed regulating dial is show stitch length (mm), can turn left or right to match your request.

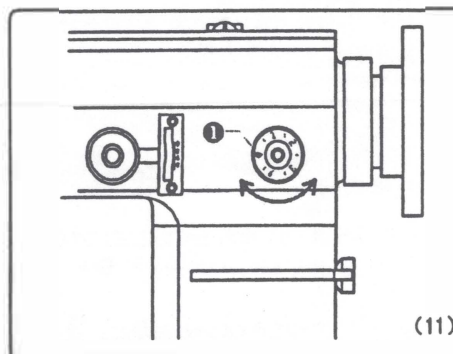

See figure (12):

7. adjusting the height of feed dog and Tilt

〈1〉 adjusting the height of feed dog

Loosen the screw of 1 , raise or lower the tooth crank to adjust the height of the feed dog.Turn the pulley until the feed dog rises to the highest position.

So the feed dog will rise to about 1.0–1.2mm above the needle plate is the best.

〈2〉 adjusting the tilt of feed dog

Loosen the screw of 5 , turn the shaft 6 to adjust the tilt of the feed dog.

After adjusted, the height of the feed dog also changed, so need to readjust the height of the feed dog.

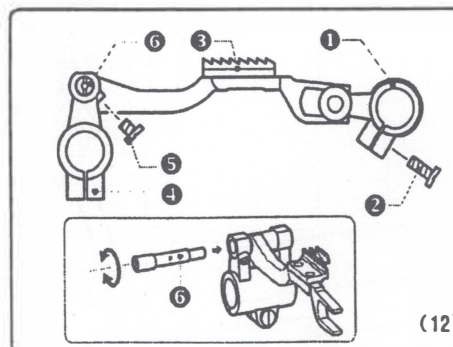

See figure (13)

8. Stitch width adjustments

<1> Coarse

Sewing dashboard ② shows the value of sewing (mm). turning the stitch width dial, adjust the stitch width roughly, A direction decreases, B direction of the sewing increases.

<2> fine tuning

Open the rubber ③, Use a screwdriver to rotate the eccentric Shaw ④, Adjust the stitch width on the left-right slightly.

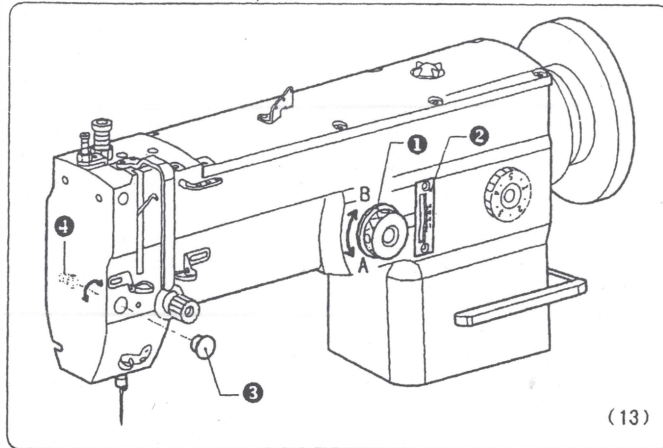

(13)

Five, Trouble causes and solutions

NO	Fault Status	View Matters	cause of issue	Approach
1	broken needle	Direction of the needle、 height	The needle in the wrong direction	To the upper right direction
		Direction of the needle、 height	Looper	Change needle
		Feed dog stroke	Needle bar does not run with the feed stroke	Adjust the feed dog stroke
		The needle bar lift amount	Needle and hook bad trip	Adjust the feed dog stroke
		Needle bar height	Needle and hook bad trip	Adjust the feed dog stroke
		Needle and bobbin main distance	Needle and hook bad trip	Adjust the feed dog stroke
2	broken thread	Threading method	Threading Error	The correct way threading
		Sewing needle	Needle tip has been bent or broken	Change needle
		Direction of the needle height	Bad position on the needle	The needle in the right direction
		Upper thread tension	Upper thread tension is too strong	Adjusting the thread tension
		The bottom line tension	The thread tension is too strong	Adjust the bottom line tension
		The thread spring exercise	Too much exercise	Adjusting spring exercise
		The thread tension spring	Pick-up spring tension too weak	Adjust the spring tension of the thread
3	bad line	Thread tension	Bottom、 upper thread tension is bad	Adjust the bottom thread tension
		The thread tension spring	Bad the thread tension spring	Adjust the thread tension spring
		Presser	Presser foot too high	Adjust the presser foot height
		The pressure of presser foot	The pressure of presser foot is too small	Adjust the presser foot pressure
4	Stitch disorder	Feed dog height	Feed dog height is too low	Adjust the feed dog height
		The pressure of presser foot	The pressure of presser foot is too small	Adjust the pressure of presser foot
		Bobbin	Bobbin scratches	Polished smooth or replace
		V-belt tension	Belt tension is too small	Adjust the belt tension
5	Sewing material fold	Upper thread tension	Upper thread tension is too strong	Adjusting the thread tension
		The bottom line tension	The thread tension is too strong	Adjust the bottom line tension
		The thread tension spring	Bad the thread tension spring	Adjust the thread tension spring
		Vaulting box spring exercise	Too much exercise	Adjusting spring exercise
		The pressure of presser foot	The pressure of presser foot is too small	Adjust the pressure of presser foot
6	The bottom line tangled	Bobbin	Pull the bottom line、 reverse the bobbin	Reverse the bobbin
		Bobbin	Bobbin is not turning smoothly	Replace the bobbin
		Bobbin winding amount	Excessive amount of winding	Limit of no more than 80%



1 800 268 1649
www.reliablecorporation.com