

Designer Diamond™

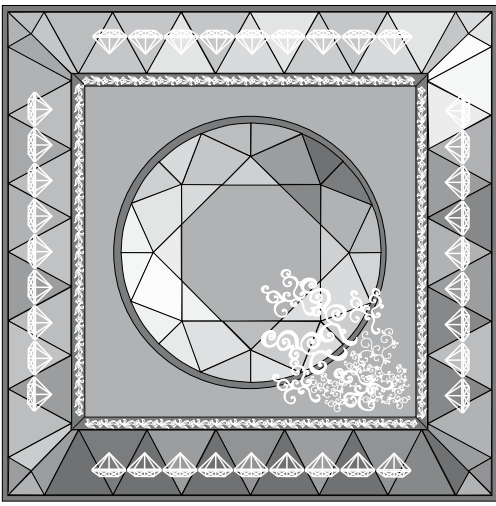

Quilt







Approximate Size 76" x 76" (190 x 190 cm)

Sewing level 3

Sewing supplies

 HUSQVARNA VIKING® DESIGNER DIAMOND™ sewing and embroidery machine

 1/3 yard (30 cm) each of 26 different Batiks or Tone on Tone prints for pieced center and outer border (ranging in colors of the color wheel)

 1 1/2 yards of 60" wide (1.4 m x 150 cm) Blue satin for quilt center, bias border, inner border and binding

 1 1/2 yards of 55" wide (1.4 m x 140 cm) Light blue silk for background

 80" x 80" (200 x 200 cm) Backing

 80" x 80" (200 x 200 cm) Thin cotton batting

 Sewing thread

 White rayon thread

 Bobbin thread

 Invisible thread

 Embroidery needle

 1/4" (6 mm) wide Fusible Web

 Tear away stabilizer

 3 1/4" strips of Inspira Tear-a-away light Stabilizer

 Pictogram pen

 Chaco Liner – White

 Marking pencil

 Template plastic or card stock

 Olfa 45 mm Deluxe Rotary Cutter

 Omnigridd Ruler 6" x 24"

 Cutting mat

 Small sharp scissor or a Surgical Seam Ripper (Havels #140000165)

 Safety Pins for “basting” the Quilt

HUSQVARNA VIKING® Accessories

 Open Toe Foot #412 80 09-45

 Clear View S-Foot #412 97 51-45

 Edge/Joining Foot #412 79 68-45

 Clear B Edge/Joining Foot #413 05 84-45

 Open Toe Free Motion Spring Foot #413 03 76-45 or Open Toe Stippling Foot #412 80 10-45

 Quilter's 1/4" Piecing Foot #412 78 55-45

You can find these and many other accessories in the HUSQVARNA VIKING® Accessory User's Guide or on our website www.husqvarnaviking.com, for purchase at your nearest HUSQVARNA VIKING® Dealer.

Assembly Instructions:

- Trace templates onto template plastic or card stock and cut out. Note: 1/4" seam allowance included on all templates.

Templates 1, 3, 4, 5, 7 and 8 – Facet Templates

Template 6, 6a and 2, 2a – Join Facet Template 6, to 6a and 2, to 2a according to markings on template.

Template 9 – Triangle template for outer border.

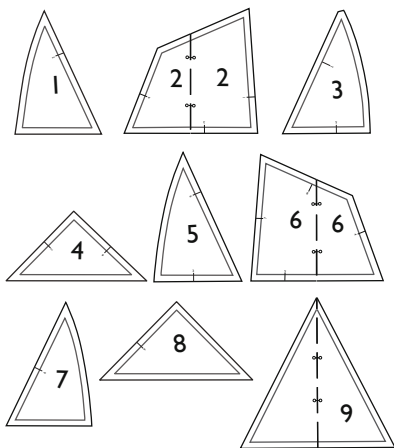

- Make a chart of each of the 26 different Batiks or Tone on Tone prints, numbering them from 1 – 26.

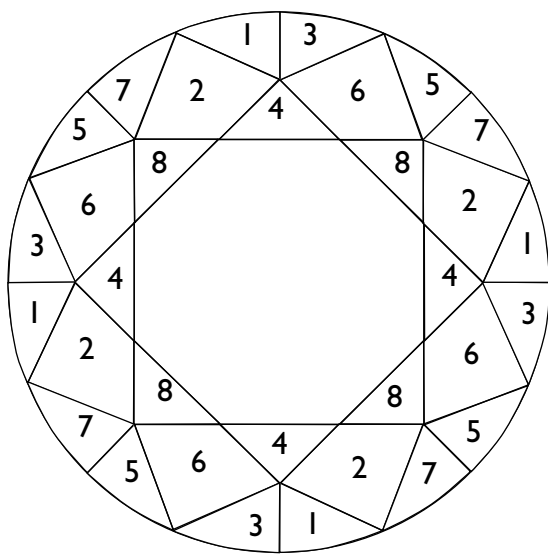

- Number the diagram for the quilt center with the fabric numbers. Some fabrics will be used twice in the facets of the center.

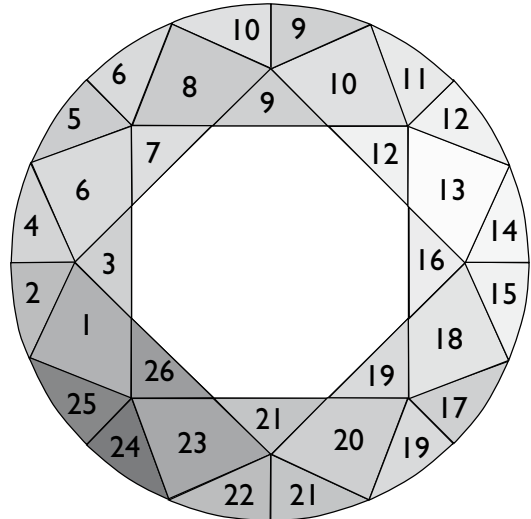

Cut:

1/4" (6 mm) seam allowance is included in all measurements.

26 different Batiks

- Cut the templates for the facets according to the illustration
- Cut 2 or 3 triangle templates from each of the 26 Batiks for the triangle outer borders

Blue satin

- 1 – 24" x 24" (61 x 61 cm) Quilt center
- 2" (5 cm) bias strips enough to measure 140" (350 cm). You will need to join the strips end to end, to achieve the length required (see illustration for cutting these pieces)

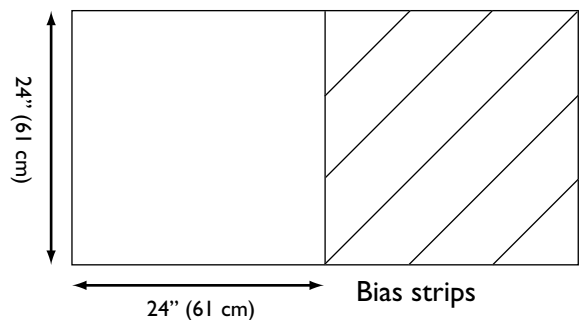

- 4 – 2 1/2" x 60" (6.5 x 150 cm) Narrow borders
- 6 – 2 1/2" x 60" (6.5 x 150 cm) Binding

Light Blue silk

- 1 – 51" x 51" (131 x 131 cm) background

Backing

- 80" x 80" (200 x 200 cm)

Batting

- 80" x 80" (200 x 200 cm)

Sew:

1. On the wrong side of each of the facet pieces mark the 1/4" (6 mm) seam allowance with a marking pencil.

Thread your DESIGNER DIAMOND™ sewing machine with sewing thread in the top and bobbin. Snap on your Quilter's 1/4" Piecing Foot. Choose Woven Medium and Seam on your Exclusive SEWING ADVISOR™ feature.

2. Lay out the facet pieces according to the quilt diagram.

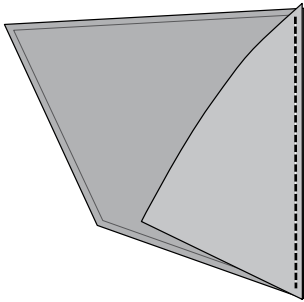

3. Place piece 1 & 2 right sides together and sew from intersection point to intersection point using a 1/4" (6 mm) seam allowance.
4. Press the seam open.
5. Continue sewing your pieces together and press until you have completed the facet center of the quilt. Some of the facets are set in seams so it is important that you only stitch from intersection point to intersection point.

6. On the completed facet center, turn under the 1/4" (6 mm) seam allowance on all the inside raw edges and press in place. Tip: Use 1/4" (6 mm) Fusible Web to secure the seam allowance.

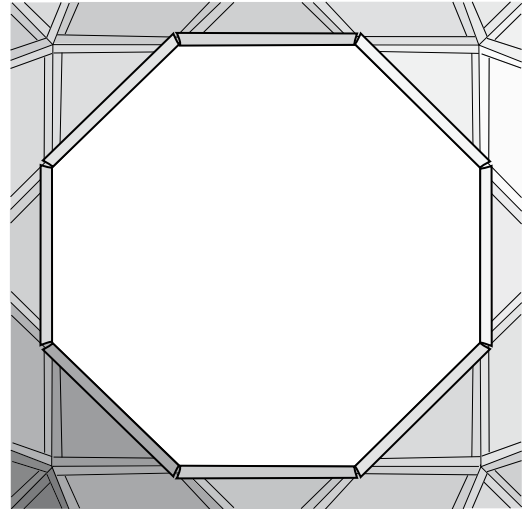

7. Center the 24" (61 cm) blue satin square under the pieced facet circle. Pin in place.
8. Thread your machine with invisible thread on top and bobbin thread in the bottom. Snap on your Open Toe Foot and select appliqué stitch E1:23 [].

Line up the edge of pieced facet with the right inside edge of the Open Toe Foot. Touch ALT. The Stitch Width changes to Stitch Positioning. Plus to 2.5 to adjust the stitch positioning to position the edge of the stitch at the edge of the facet circle. Appliqué the pieced facet center to the blue satin square.

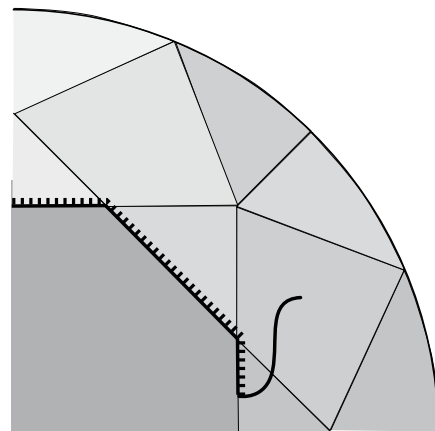

9. Trim the excess blue satin from the back.
10. Thread your DESIGNER DIAMOND™ sewing machine with sewing thread in the top and bobbin. Snap on your Quilter's 1/4" Piecing Foot.
11. Piece the 2" (5 cm) blue satin bias strips to form one long strip. Press the seams open and then press the strip in half, wrong sides together.
12. Sew the bias strip with raw edges matching around the outer edge of the facet pieced circle. Turn under the raw edge where the strips join.

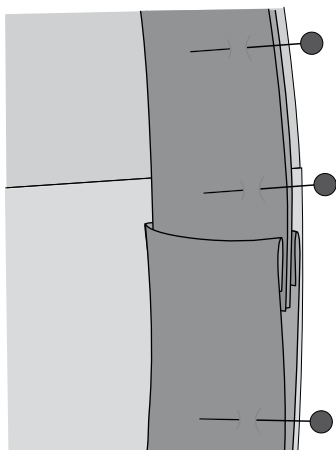

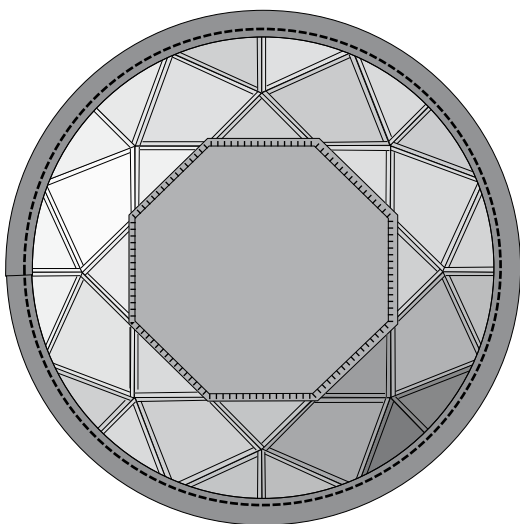

13. Press the seam allowance towards the facet pieced circle.

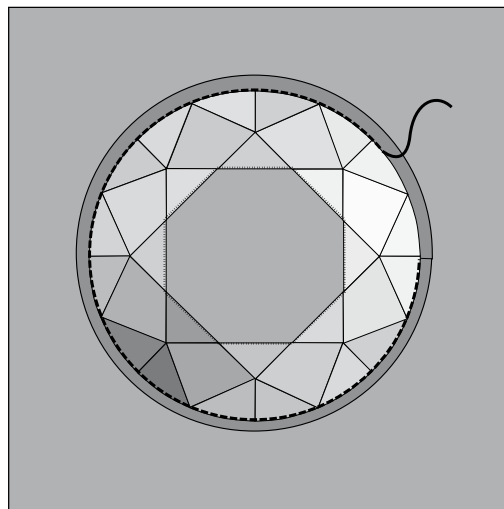

14. Center the pieced facet circle on the light blue silk square and pin in place. Thread your machine with invisible thread on top and bobbin thread in the bottom. Snap on your Edge/Joining Foot and stitch in the ditch between the bias strip and the facet pieced circle to attach to the light blue silk square. Note: The outer edge of the bias strip is not stitched down.



15. Embellish the narrow blue satin borders with Omnimotion stitches. To program stitch K16  and K8  together, touch PROG, touch K16, K8 then step on the foot control to sew. Draw a line down the center of each border with the Chaco Liner. Snap on your Clear S Foot. Place the 3 1/4" strips of tear-a-way light stabilizer under the border strip and stitch with white rayon thread on top and bobbin thread in the bottom on all 4 of the borders. Tear the stabilizer away and press.

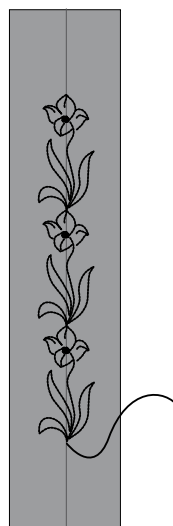

16. Stitch the narrow border to the quilt top, mitering the corners. Make sure the quilt and the borders are the same size by measuring and marking both corner intersection points and centers.

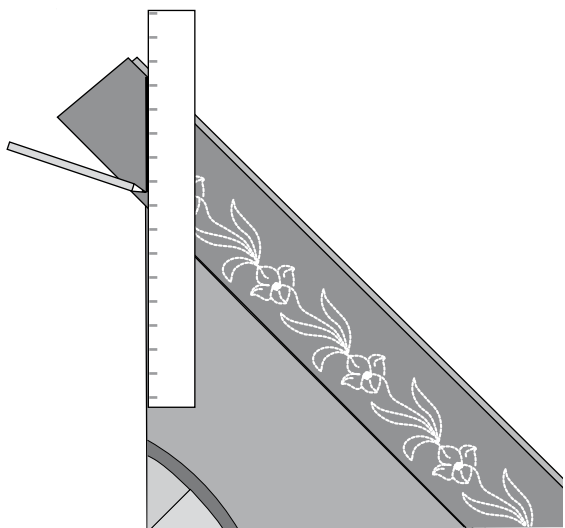

17. Lay out the outer border triangle pieces following the color wheel. You will use some of the fabrics two or three times in the border. Each border consists of 15 triangles per border strip. See illustration.

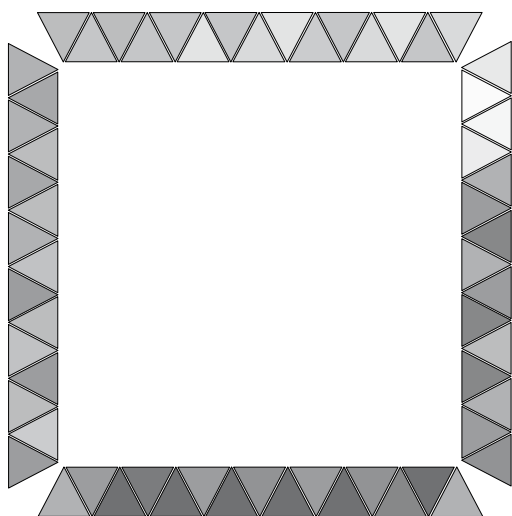

18. Sew each border strip consisting of 15 triangles together and press.
19. Sew each of the border strips to the quilt and miter the corners.

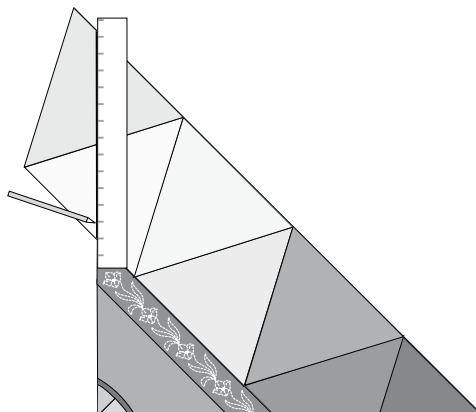

Decorative stitching:

1. Snap on your Clear B Edge/Joining Stitching foot and thread your machine with white rayon thread on top and bobbin thread in the bottom.
2. Place the guide along the ditch and stitch in the seam lines of all the facet pieces with some of the beautiful decorative quilting stitches. There are 72 stitches on the Quilt Menu E and many fabulous stitches on other menus. Place tear away stabilizer underneath as needed.

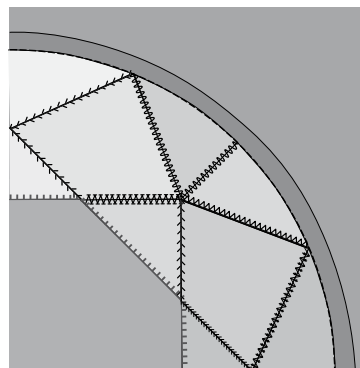

Embroidery:

1. Attach the embroidery unit and Clear Embroidery Foot R.
2. Select the large diamond facet design from the embroidery designs that come with your DESIGNER DIAMOND™ sewing and embroidery machine.
3. Hoop the outside borders with stabilizer and use Design Positioning to place the embroideries exactly where you want them.
4. Embroider 3 repeats—this is a single design. Touch the design and duplicate it twice to bring three onto the Ultimate Interactive Screen. Embroider three, then rehoop and continue until you have embroidered the the Diamond outline embroidery on each of the pieced borders The Endless Embroidery Hoop (sold as an accessory) makes this easy.

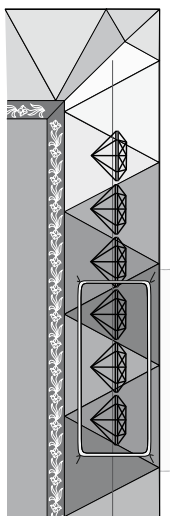

5. Embroider the scroll designs from the embroideries that come with your DESIGNER DIAMOND™ sewing and embroidery machine



on the quilt center. Use Design Positioning to place the embroideries where you want them on the quilt.

6. When you have finished embroidering, cut some of the embroideries to make a thread velvet effect using small sharp scissors or a Surgical Seam Ripper. For instructions see the embroidery booklet.

Quilt your Quilt:

1. Layer your quilt top, batting and backing forming a quilt “sandwich”. The backing should be right side down, then the batting and the quilt top right side up on top. Safety pin baste the quilt through all the layers.

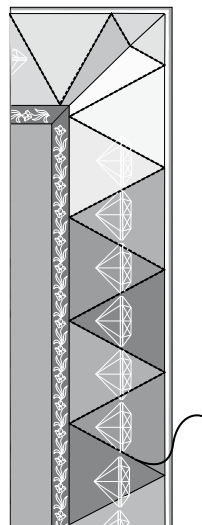

2. Snap on your Edge/Joining foot and thread your machine with Invisible thread on top and in the bobbin. Select a straight stitch and quilt the border sections “in the ditch” of the seams.
3. Attach the Free Motion Foot of your choice and stipple quilt the background.

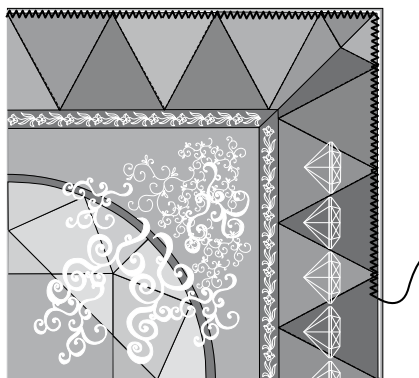

4. Snap on your B foot. Thread your machine with regular sewing thread top and bottom. Select a 3 Step Zig Zag and stitch around the edge of the quilt top.
5. Trim the excess backing and batting even with the edge of the quilt top.

Binding:

1. Sew the binding strips together into one long strip. Press the seams open. Fold the binding in half lengthwise, wrong sides together, and press.
2. Place the binding on the right side of the quilt with the raw edges even. Snap on your Quilter's 1/4" Piecing Foot. Stitch the binding in place around the quilt. Fold the folded edge of the binding to the wrong side of the quilt and stitch in the ditch from the right side with the Edge/Joining foot and Invisible thread on top and bottom.

